

**PAVEMENT MARKING NOTES:**

- STREET WIDTH MEASUREMENTS ARE FROM FACE OF CURB TO FACE OF CURB.
- LANES ARE MEASURED FROM CENTER OF MARKING TO CENTER OF MARKING.
- CONTACT DES-TRANSPORTATION ENGINEERING & OPERATIONS CONSTRUCTION MANAGEMENT SPECIALIST OR HIS DESIGNER AT 703-228-6598 OR 571-431-1077 TO APPROVE MARKING LAYOUT 48 HOURS PRIOR TO INSTALLATION OF MARKINGS.
- PAVEMENT MARKINGS TO BE IN ACCORDANCE WITH THE FOLLOWING AND ANY EXISTING THE MANUAL ON UNIFORM TRAFFIC CONTROL DEVICES.
  - ARLINGTON COUNTY MARKING STANDARDS.
  - ALL MARKINGS SHALL BE THERMOPLASTIC PER ARLINGTON COUNTY MARKING STANDARDS.
  - STOP BARS SHALL BE A MINIMUM OF 4" IN ADVANCE OF A MARKED CROSSWALK. IF THERE IS NO MARKED CROSSWALK, STOP BAR SHALL BE NO MORE THAN 30' FROM THE NEAREST EDGE OF THE INTERSECTED TRAVELED WAY.
  - CROSSWALKS SHALL BE 10' WIDE UNLESS OTHERWISE NOTED.
  - LEFT TURN ARROWS SHALL BE LOCATED 25' BACK FROM STOP BAR. FOR ON-STREET PARKING LANE'S 7' WIDE (UNLESS OTHERWISE NOTED) AND MARKED WITH A 4" WIDE WHITE LINE, BEGINNING AND END OF PARKING SHALL BE MARKED WITH AN END LINE PERPENDICULAR TO CURB EXCEPT AT CURBS OR WHERE OTHERWISE INDICATED.
  - SHARED LANE MARKINGS SHALL BE PLACED IN CENTER OF LANE, 250' APART UNLESS OTHERWISE SPECIFIED.
  - BIKE LANE SYMBOLS TO BE PLACED WHERE SHOWN ON THE PLANS.
  - FOR DETAILS SEE ARLINGTON COUNTY PAVEMENT MARKING SPECIFICATION, DETAILS MK-1 TO MK-22.

**SIGN NOTES:**

- PERIMETER OF W11-2 SIGN SHALL BE EQUIPPED WITH FLASHING LED.
- FOR ALL SIGN POSTS PLACED IN CONCRETE USE 7 GAUGE HEAVY DUTY ANCHOR (30"x2.50") WITH HARDWARE FOR 2" POST. USE #4 CORNER BOLT WITH FLANGED NUT AND #4 DRIVER RIVET WITH WASHER.
- CONTACT T&B CONSTRUCTION MANAGER OR HIS DESIGNER AT 703-228-6598 OR 571-431-1077 48 HRS PRIOR TO POURING CONCRETE. ALTERNATIVE CONTACT AT 703-228-3788 OR 571-414-7497.
- ALL EXISTING SIGNS TO BE RELOCATED SHALL BE MOUNTED WITH NEW SQUARE TUBE POST.

**STANDARD PAVEMENT MARKING LEGEND**

Ⓐ	TYPE B CLASS 1	WHITE 4" WIDTH	PARKING LINES, EDGE LINES, LANE LINES
Ⓑ	TYPE B CLASS 1	WHITE 4" WIDTH, 10' LONG, 30' SPACING	DASHED LANE LINES
Ⓒ	TYPE B CLASS 1	WHITE 4" WIDTH, 2' LONG, 10' SPACING	LANE TRANSITIONS, TURN LANE SKIPS
Ⓓ	TYPE B CLASS 1	WHITE 18" WIDTH	STOP BARS
Ⓔ	TYPE B CLASS 1	WHITE 24" WIDTH	CONTINENTAL CROSS WALKS
Ⓕ	TYPE B CLASS 1	WHITE 6" WIDTH	TURN LINES, TRANSVERSE CROSS WALKS, BIKE LANES
Ⓖ	TYPE B CLASS 1	YELLOW 4" WIDTH, 10' LONG, 30' SPACING	DIVIDED TRAFFIC, TWO WAY TURN LINES
Ⓗ	TYPE B CLASS 1	YELLOW 4" WIDTH	EDGE LINES
Ⓘ	TYPE B CLASS 1	YELLOW 4" WIDTH, DOUBLE LINE, 4" SPACING	CENTERLINES
Ⓛ	TYPE B CLASS 1	WHITE 6" WIDTH, 10' SPACING @45 DEGREE	HATCH LINES, SAFETY ZONES
Ⓜ	TYPE B CLASS 1	WHITE 6" WIDTH, 2' LONG, 10' SPACING	PAVEMENT SYMBOL, TURN LINES
Ⓝ	TYPE B CLASS 1	WHITE SINGLE ARROW	PAVEMENT LETTERS (STOP, YIELD, BUS, ONLY, etc.)
Ⓟ	TYPE B CLASS 2	WHITE COMBINATION ARROW	PAVEMENT LETTERS (STOP, YIELD, BUS, ONLY, etc.)
Ⓠ	TYPE B CLASS 1	WHITE 8' LETTERS	LANE TRANSITIONS, TURN LANE SKIPS
Ⓡ	TYPE B CLASS 1	WHITE 6" WIDTH, 2' LONG, 10' SPACING	LANE TRANSITIONS, TURN LANE SKIPS
Ⓢ	TYPE B CLASS 1	YELLOW 12" WIDTH, 20' SPACING @45 DEGREE	GORE MARKINGS
Ⓣ	TYPE B CLASS 1	YELLOW 8" WIDTH @45 DEGREE	GORE MARKINGS
Ⓤ	TYPE B CLASS 1	WHITE 6" WIDTH, 2' LONG, 4" SPACING	LANE TRANSITIONS
Ⓡ	TYPE B CLASS 1	WHITE 4" WIDTH, DOUBLE LINE, 4" SPACING	LANE TRANSITIONS
Ⓣ	TYPE B CLASS 1	WHITE 24" WIDTH, 20' SPACING @45 DEGREE	VOOI - STOP BARS
Ⓤ	TYPE B CLASS 1	WHITE 24" WIDTH, 2' LONG, 4" SPACING	VOOI - GORE MARKINGS
Ⓡ	TYPE B CLASS 1	YELLOW 6" WIDTH, 2' LONG, 4" SPACING	LANE TRANSITIONS

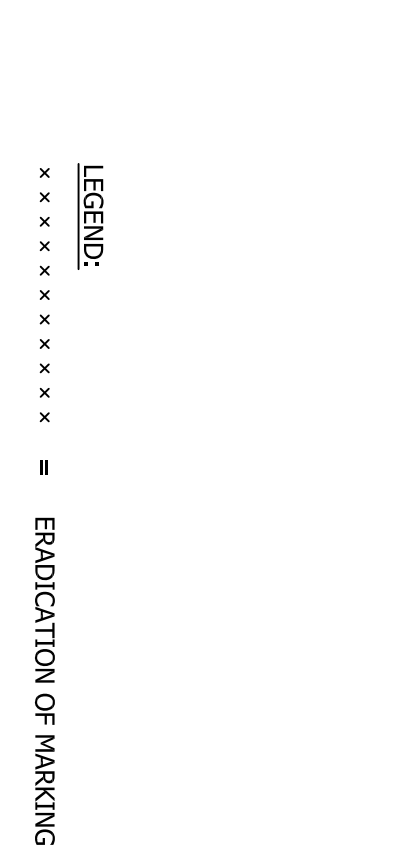
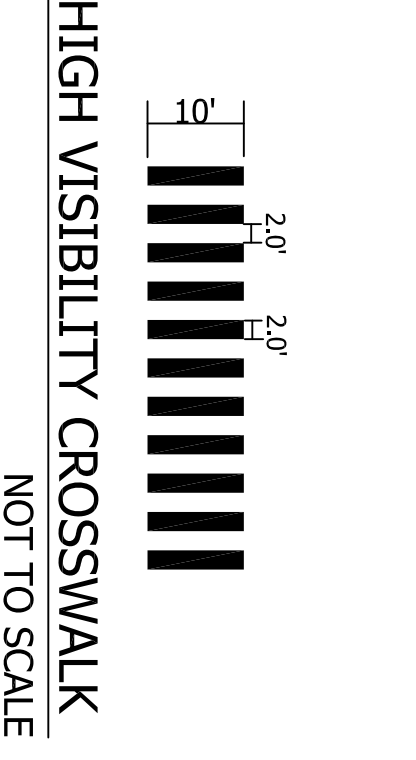
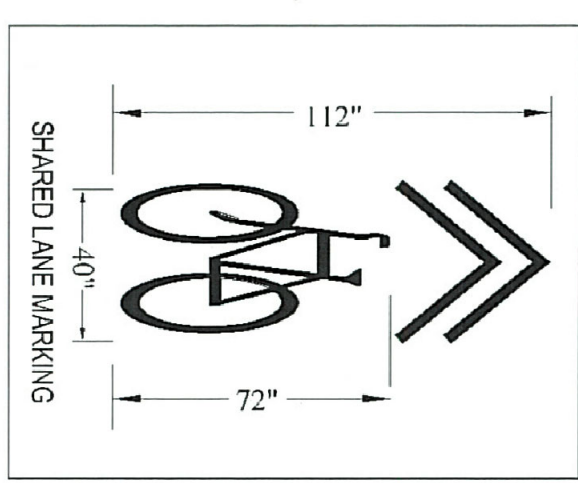
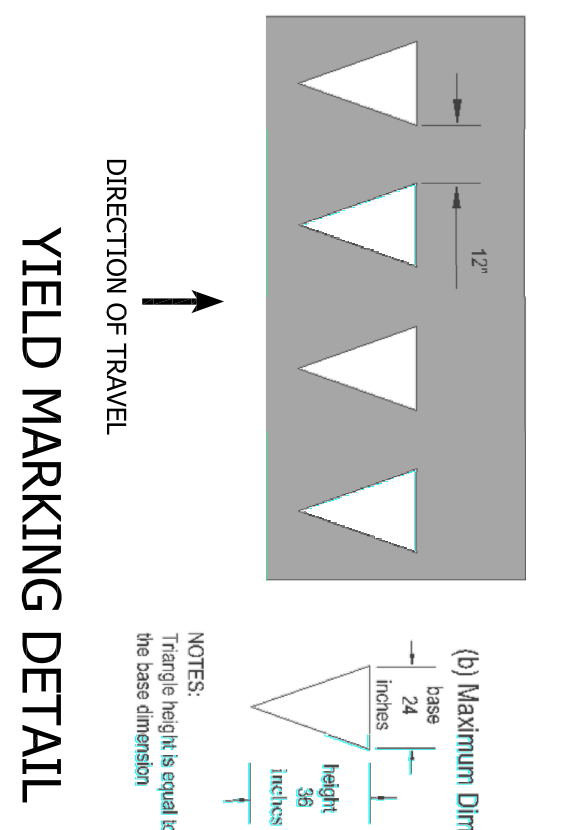

MICHAEL J. KEANE SUBDIVISION  
D.B. 151, PG. 463

PT. 9, PT. 10  
TURKSON MANAGEMENT  
CONSULTING, INC.  
#1512 S. Arlington Ridge Road

THE CAVENISH  
UNIT OWNERS ASSOCIATION  
D.B. 2056, PG. 677  
#1300 S. Arlington Ridge Road

RESUBDIVISION OF  
BROWN'S ADDITION TO  
W.R. ROSE SUBDIVISION  
D.B. 1956, PG. 173

UNIT OWNERS ASSOCIATION  
RIDGE CONDOMINIUM  
D.B. 4127, PG. 1409  
#1515 S. Arlington Ridge Road

PENTAGON PLAZA,  
INCORPORATED  
D.B. 2717, PG. 485

**ARRLINGTON VIRGINIA**

DEPARTMENT OF ENVIRONMENTAL SERVICES  
FACILITIES & ENGINEERING DIVISION  
ENGINEERING BUREAU  
2100 CLARENDON BOULEVARD, SUITE 813  
ARLINGTON, VA 22201  
PHONE: 703.228.3629  
FAX: 703.228.3606

Copyright © 2022 ARRLINGTON COUNTY  
VIRGINIA - ALL RIGHTS RESERVED

**ARRLINGTON VIRGINIA**

DEPARTMENT OF ENVIRONMENTAL SERVICES  
FACILITIES & ENGINEERING DIVISION  
ENGINEERING BUREAU  
2100 CLARENDON BOULEVARD, SUITE 813  
ARLINGTON, VA 22201  
PHONE: 703.228.3629  
FAX: 703.228.3606

Copyright © 2022 ARRLINGTON COUNTY  
VIRGINIA - ALL RIGHTS RESERVED

**S ARLINGTON RIDGE RD INTERSECTION IMPROVEMENTS**  
DC12

Intersection Of S Arlington Ridge Rd And S Lynn St, And Ramp I-395

**SIGNING AND MARKING PLAN**

DESIGNED: LED  
DRAWN: LED  
CHECKED: JL

PLOTTED: SEPTEMBER 22 2022

SCALE:

**C101.1**

PROJECT MANAGER

REVISIONS

DATE

TRANSPORTATION DIRECTOR

WATER, SEWER, STREETS BUREAU CHIEF

CONSTRUCTION MANAGEMENT SUPERVISOR

APPROVALS

DATE

QUALITY CONTROL ENGINEER

SEAL