



2405

PRIVATE  
PARKING  
UNAUTHORIZED VEHICLES  
WILL BE TOWED AWAY  
AT VEHICLE OWNER'S  
EXPENSE AND RISK

PRIVATE  
PROPERTY  
NO  
TRESPASSING

NO TRESPASSING



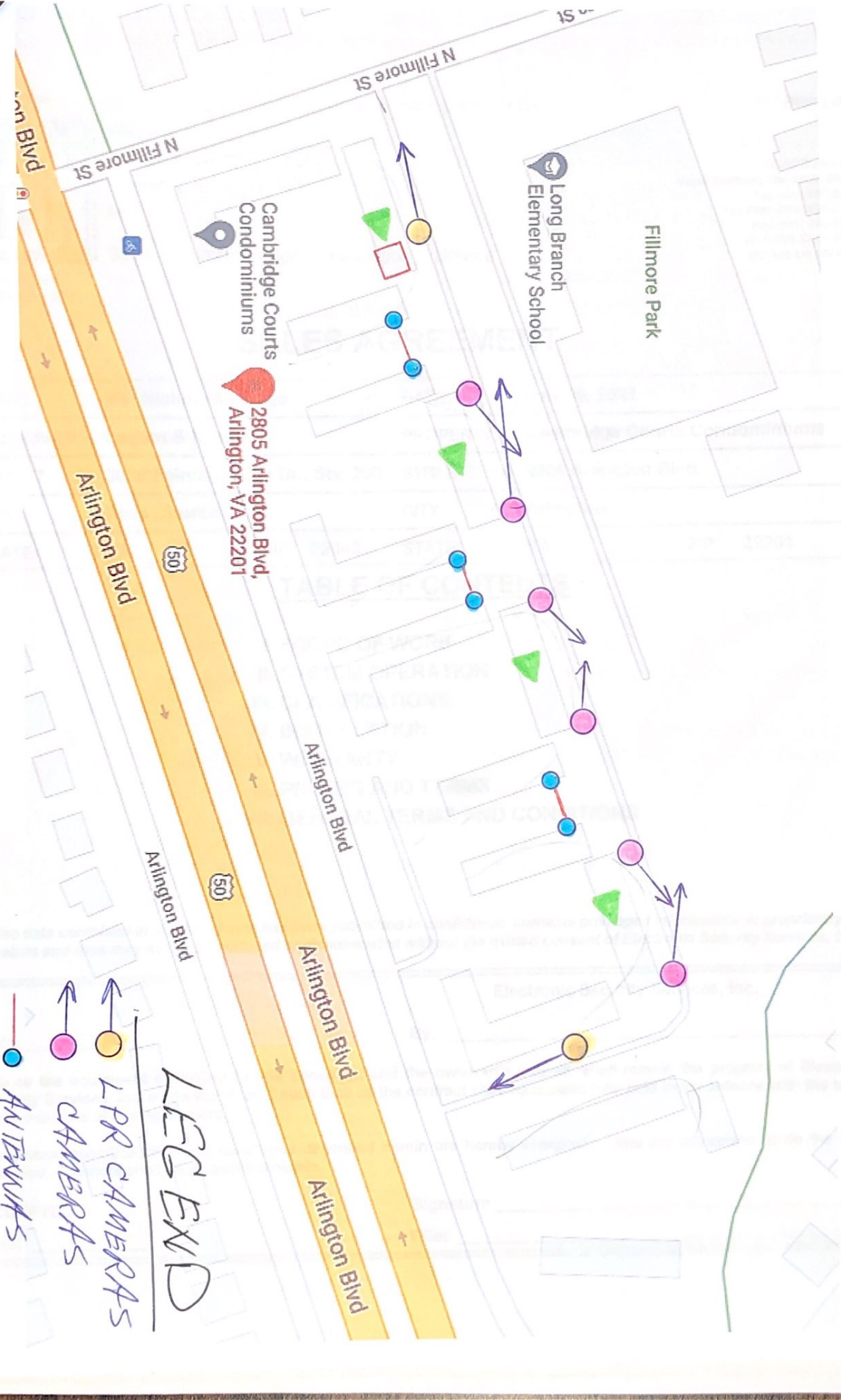

**LEGEND**

- LPR CAMERAS
- CAMERAS
- ANTENNAS
- VIDEO RECORDER
- ▲ NETWORK SWITCHES

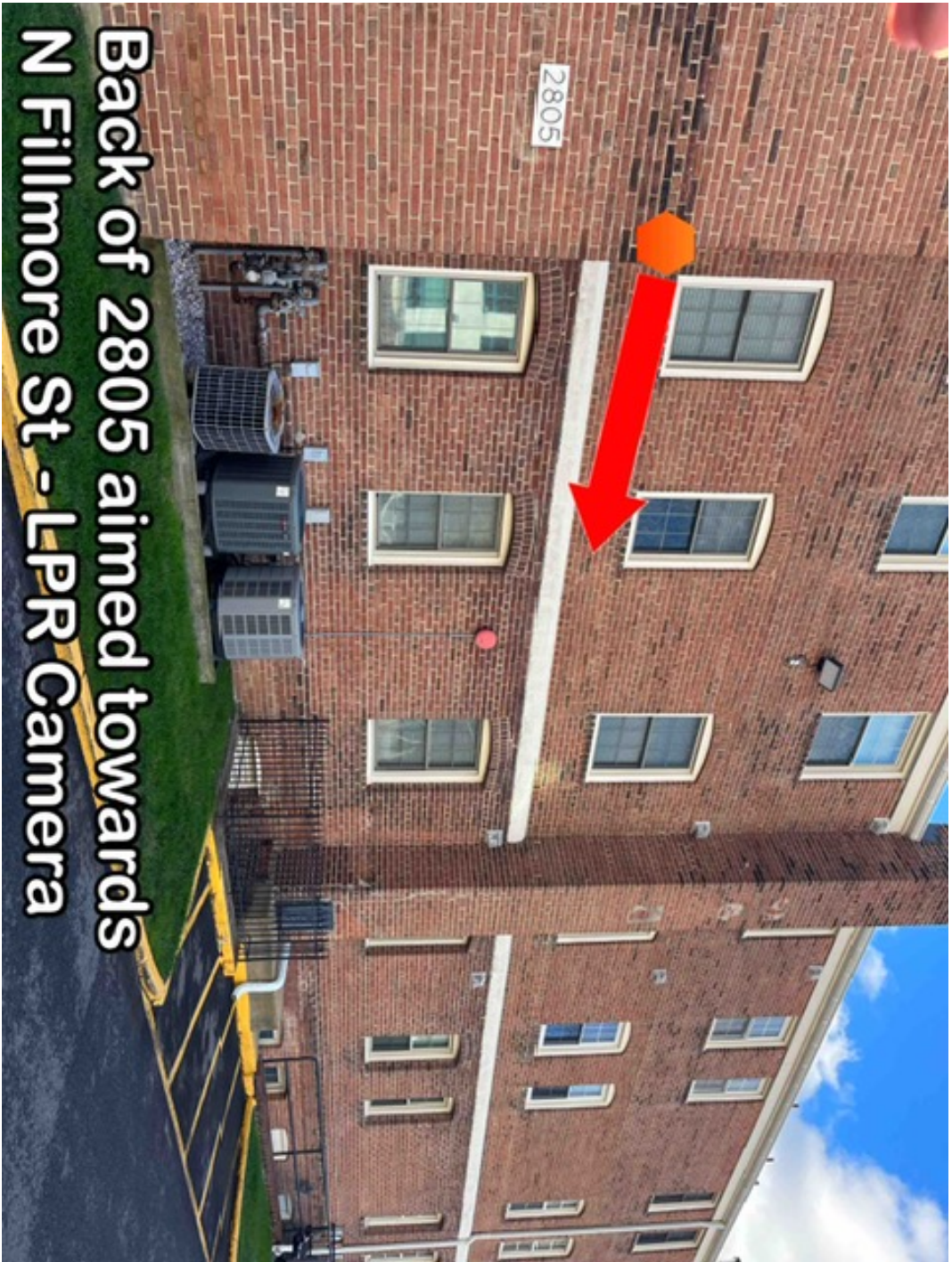

**Back of 2805 aimed towards  
N Fillmore St - LPR Camera**

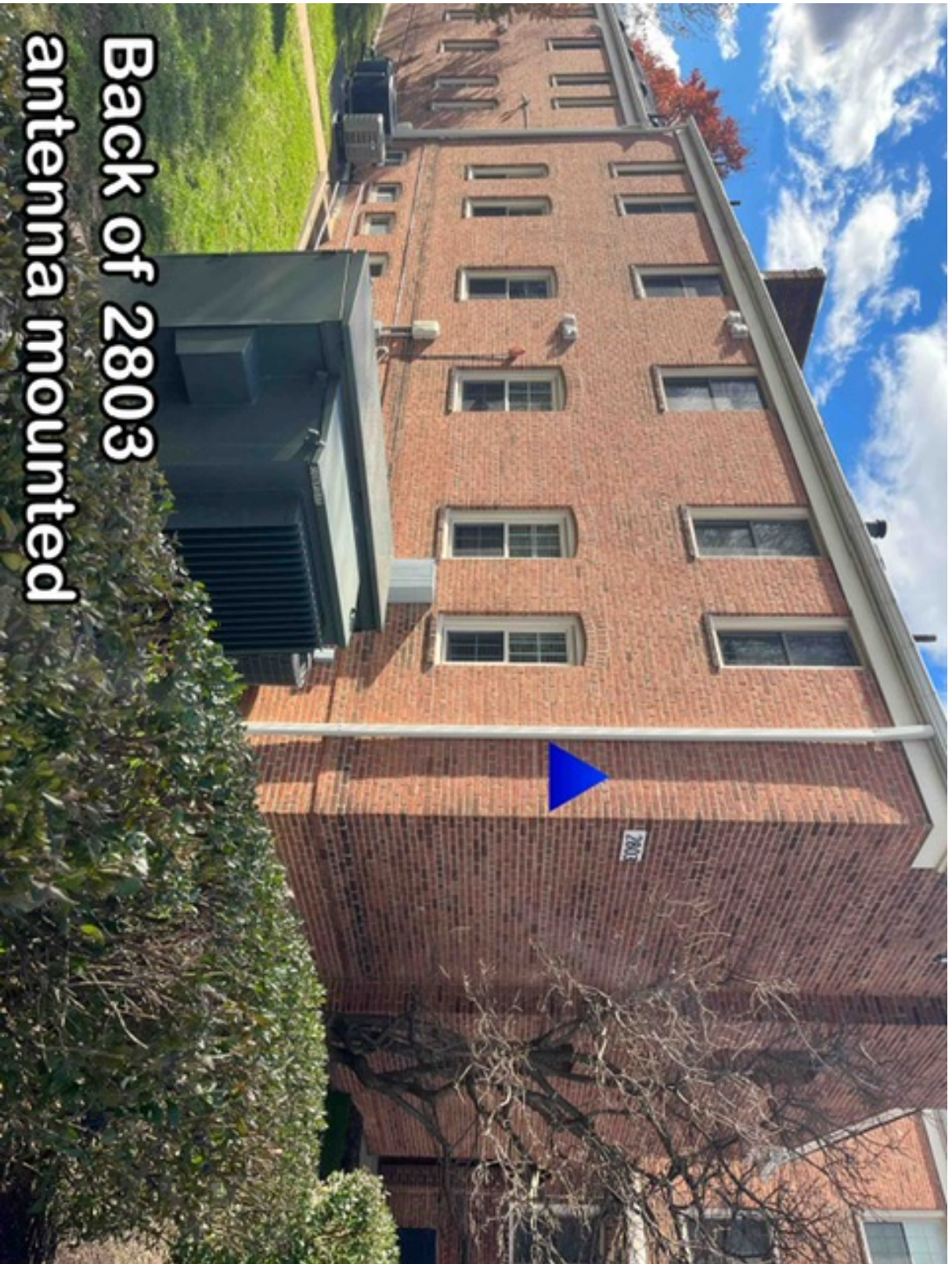

**Back of 2803  
antenna mounted**

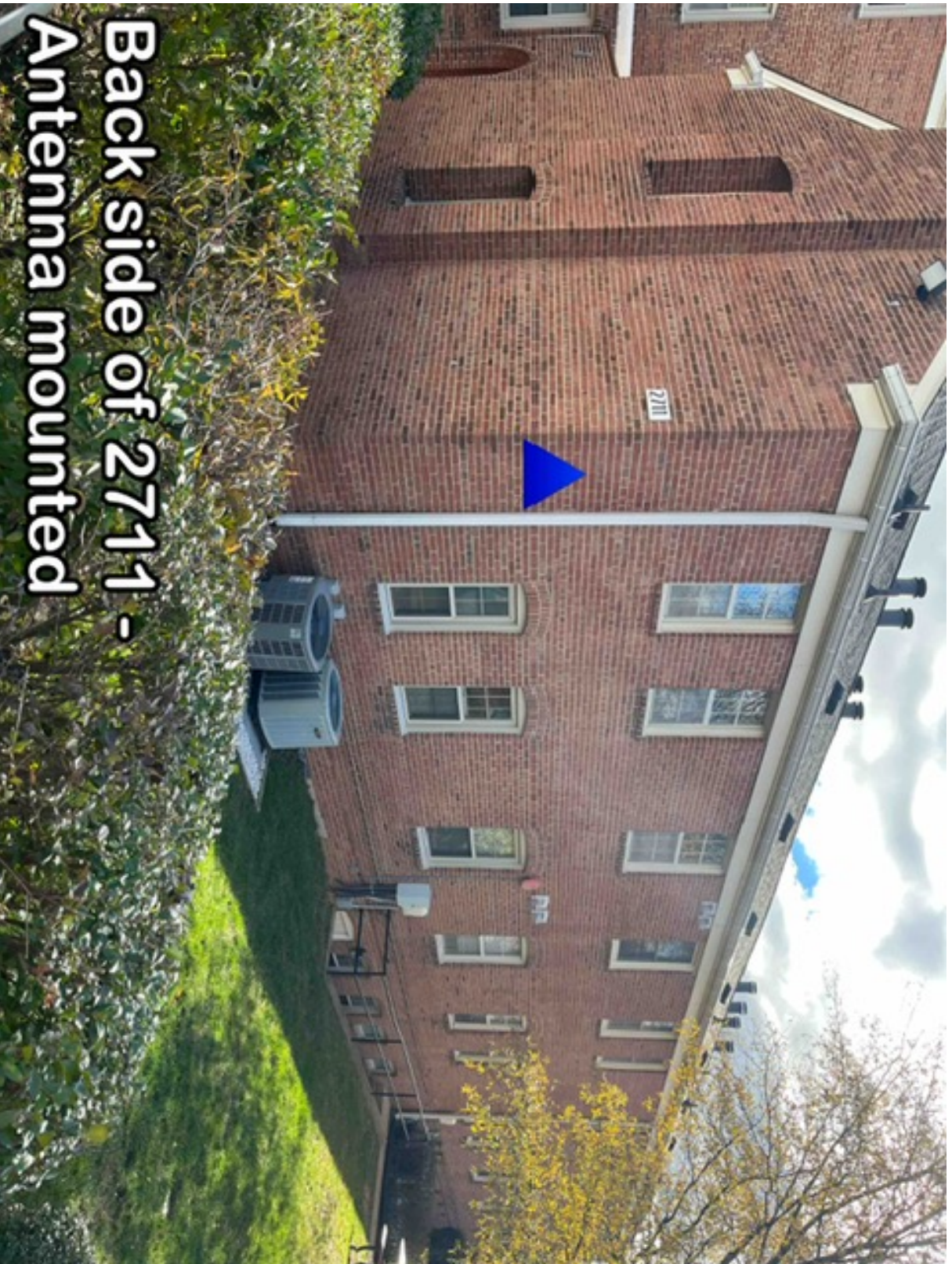

**Back side of 2711 -  
Antenna mounted**



**Back side of 2709 -  
Camera mounted aimed  
away from N Fillmore St**

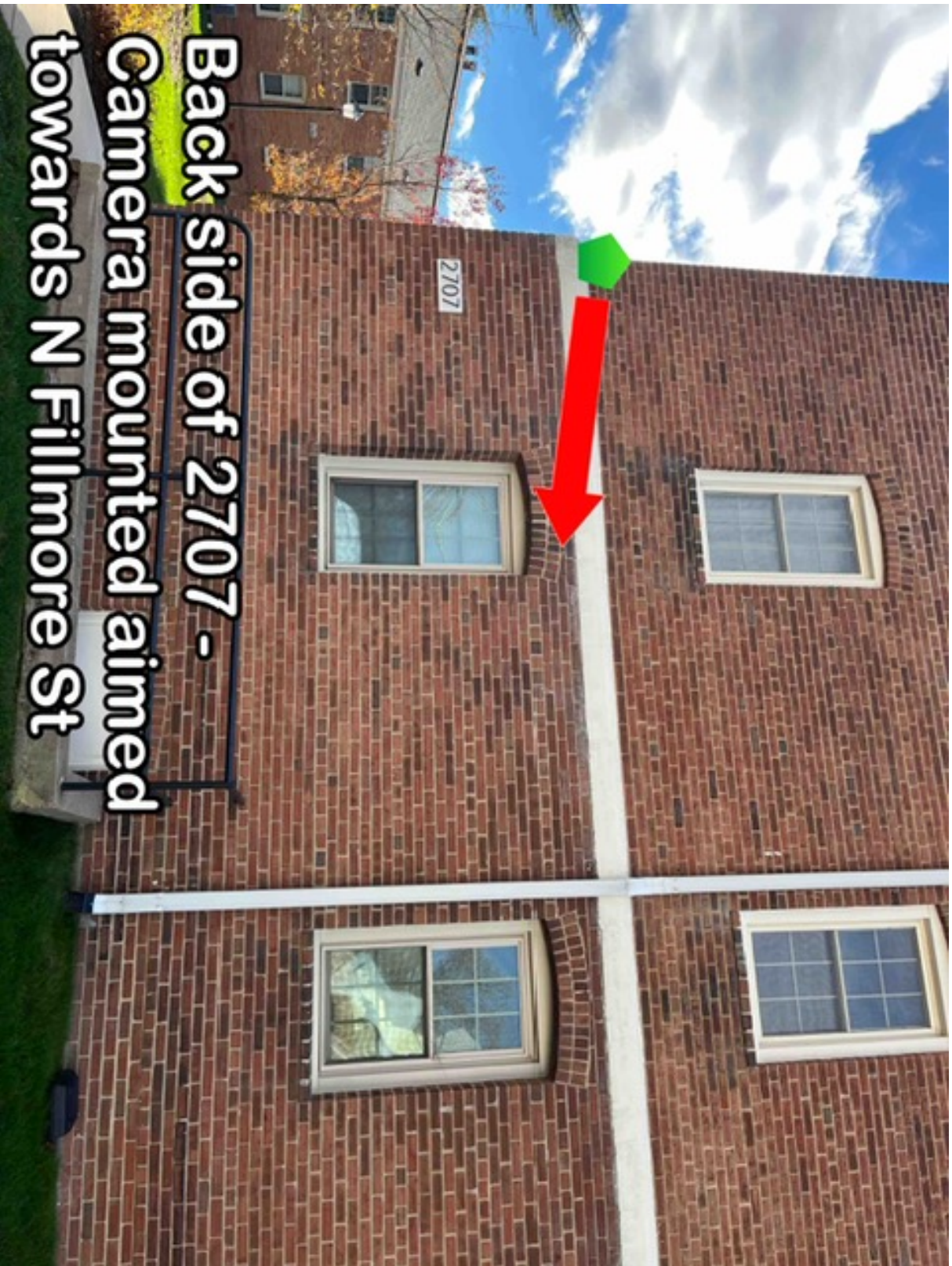

**Back side of 2707 -  
Camera mounted aimed  
towards N Fillmore St**



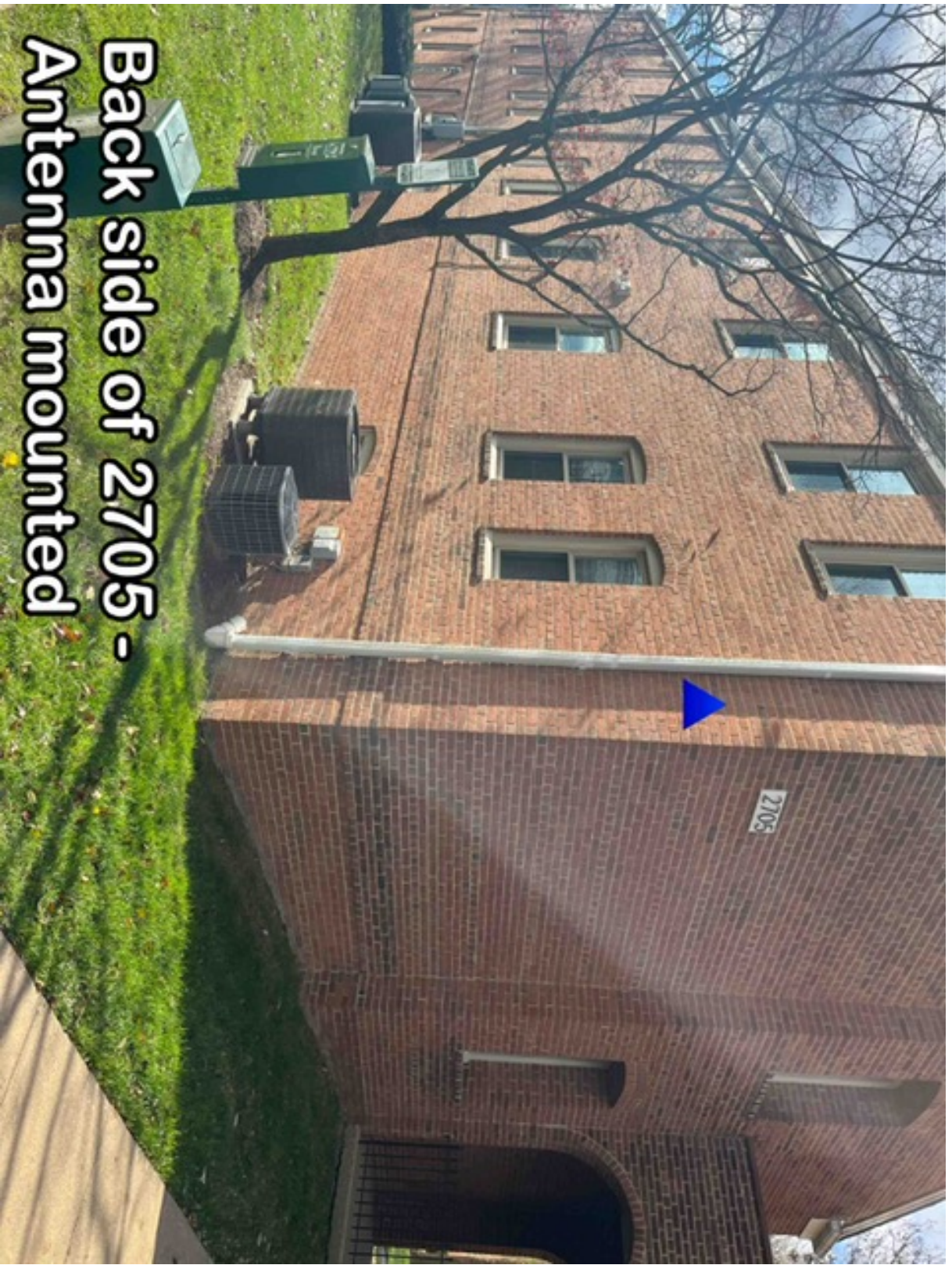

**Back side of 2705 -  
Antenna mounted**



**Back side of 2609 -  
Antenna mounted**



**Back side of 2607 -  
Camera mounted aimed  
away from N Fillmore St**



**Back side of 2605 -  
Camera mounted aimed  
towards N Fillmore St**

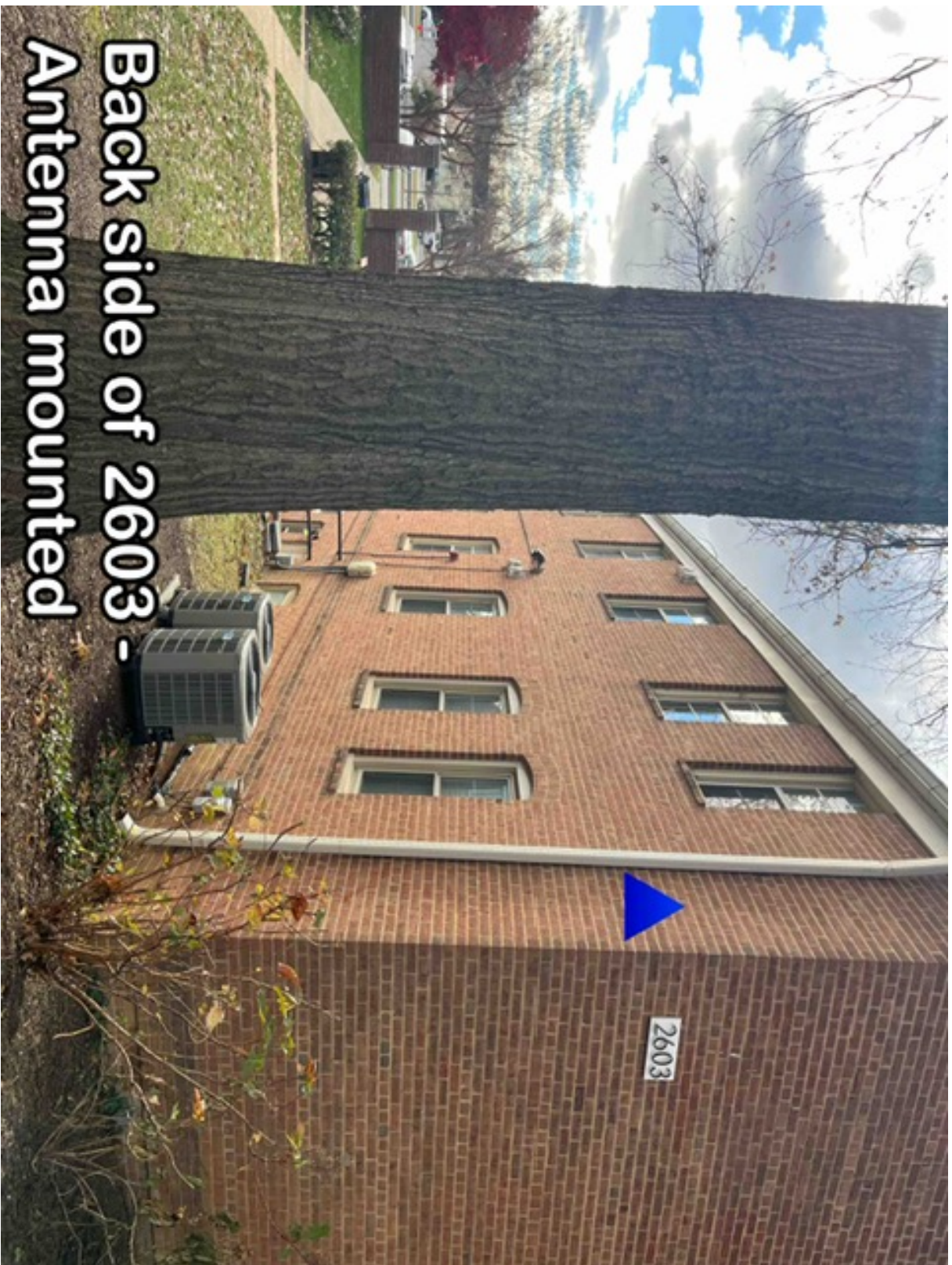

**Back side of 2603 -  
Antenna mounted**

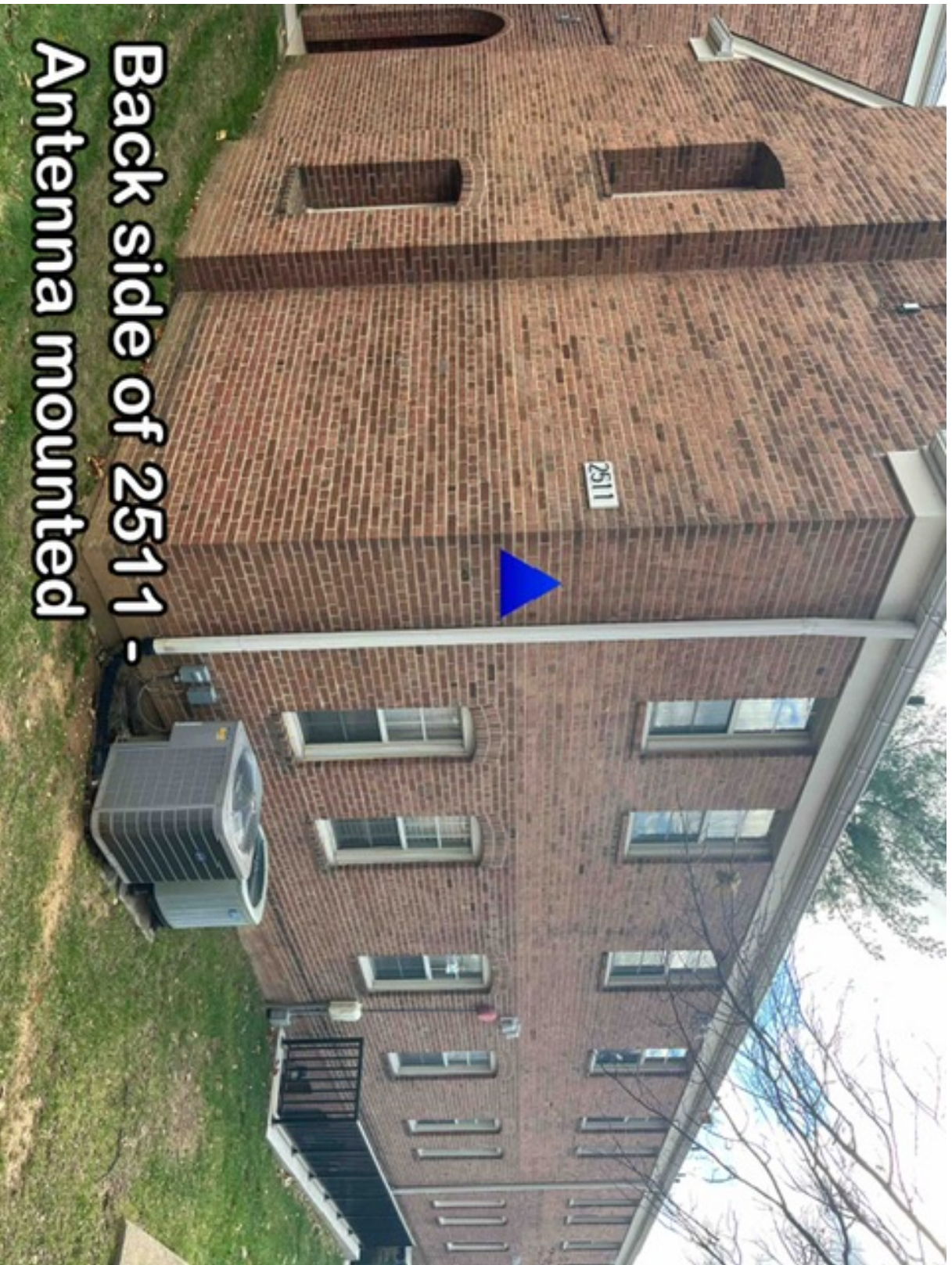

**Back side of 2511 -  
Antenna mounted**



**Back side of 2509 -  
Camera mounted aimed  
away from N Fillmore St**



**Back side of 2507 -  
Camera mounted aimed  
towards N Fillmore St**



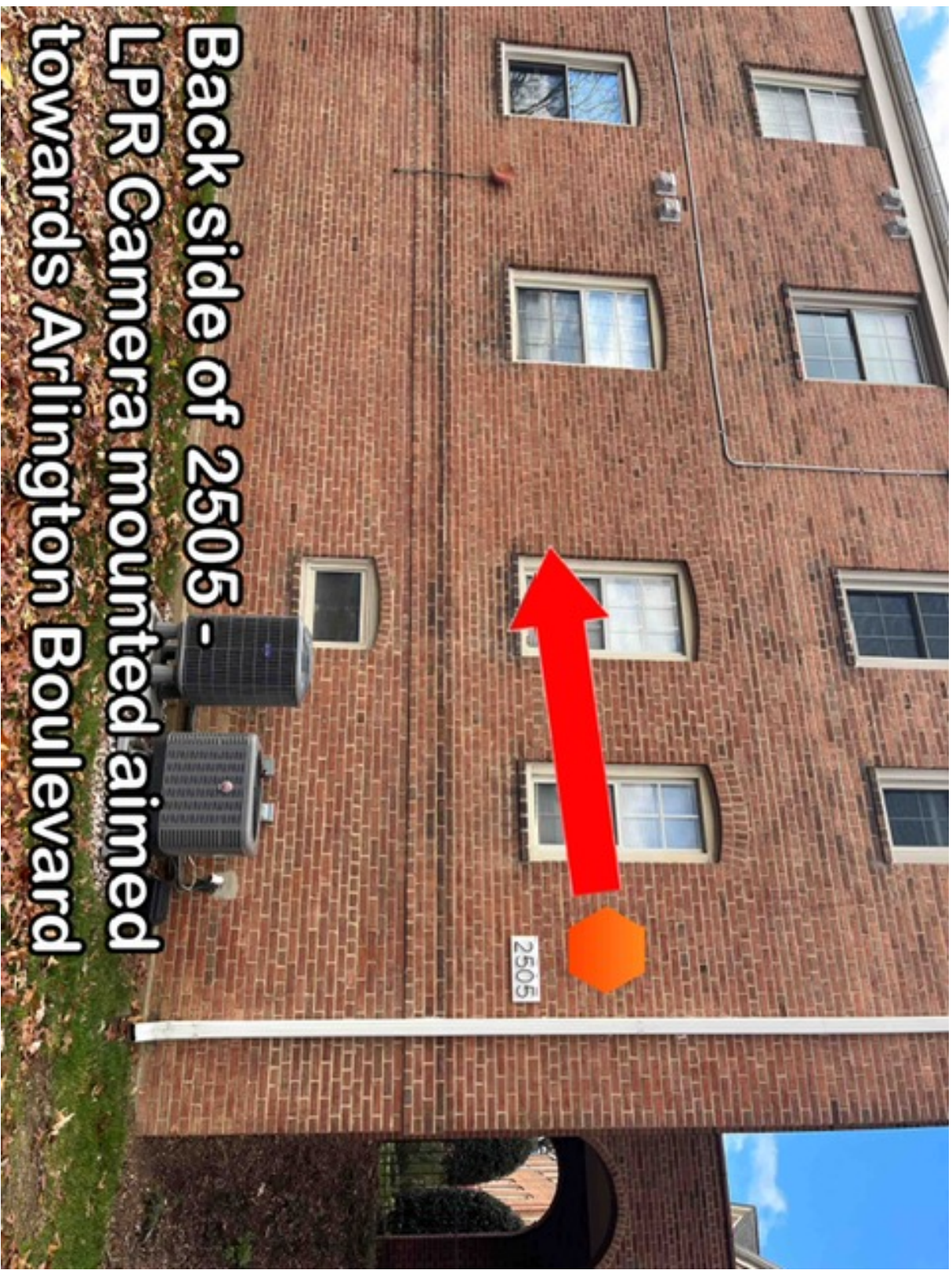

**Back side of 2505 -  
LPR Camera mounted aimed  
towards Arlington Boulevard**

# Cambridge Courts Condominium Arlington, VA

Long Branch  
Elementary School



Fillmore St.

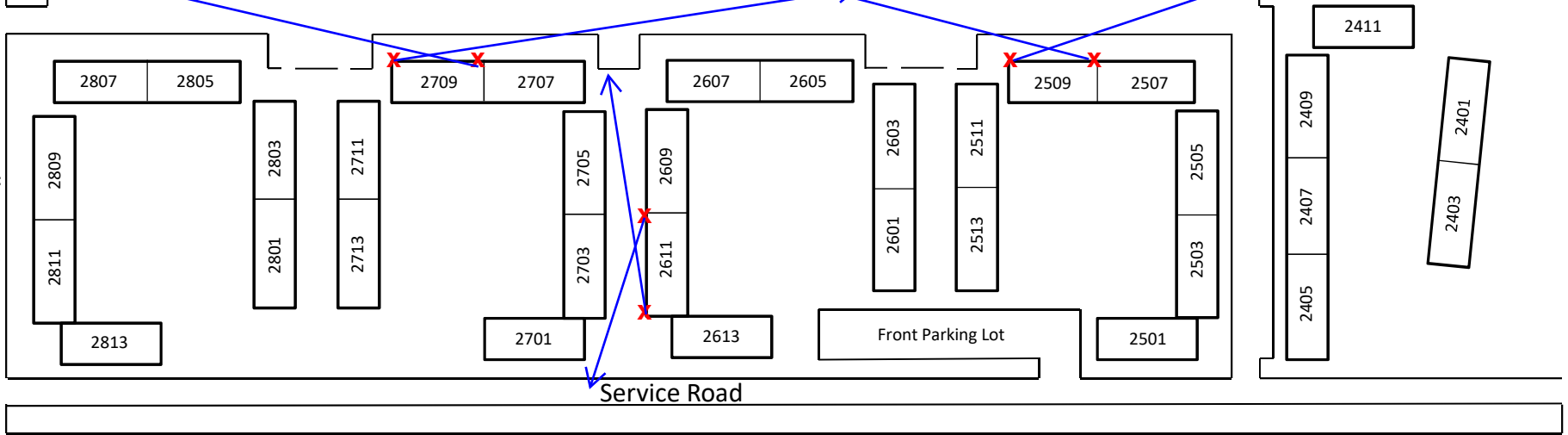

Rt. 50

\*Map not to scale

## VIGILANT FLEX SERIES



Powered by MStar™ chipsets that meet federal government technical requirements

## ALIBI VIGILANT FLEX SERIES 4MP STARLIGHT IP VANDAL-RESISTANT DOME CAMERA

### Key Specifications:

- + 4MP IP dome camera
  - + 2.8mm fixed lens
  - + 101.1 degrees Field of View
  - + 98 feet Smart IR Distance
  - + Starlight chipset for color in low light
  - + MicroSD card slot
    - up to 256GB
  - + 0.003 low-light Lux rating
  - + 120dB True WDR
  - + ANR,NAS(NFS) Network Storage
  - + IK10 vandal-resistant
  - + IP67 rating - withstands temps from -22 degrees to 140 degrees Fahrenheit
  - + NDAA compliant
- + **Multi-megapixel resolution** - Get more detail from your video camera. This camera captures multi-megapixel resolution video footage that delivers crisp, precise detail and clarity for your video security needs.
  - + **IK10 vandal-resistant** - durable design for around-the-clock surveillance. Built for high resistance to impact, the metal encased design of this vandal dome camera is unmatched by anything on the market -making it a safe and secure camera for years to come.
  - + **Smart IR** - Night vision that goes the distance. Smart IR technology offers several advantages over standard IR for flawless night vision, including:
    - Clearer, brighter images in low light and at night
    - Reduces overexposure of the IR LEDs at the center of the image
    - Increases illuminant efficiency up to 30%
    - Produces LED light in rectangle form to better fit screen size
    - Captures images up to 98 feet in the dark without washing out the subject at closer ranges
    - Reduces video noise for a clearer nighttime picture, and reduces bandwidth consumption and video storage requirements
  - + **Ultra 265 Compression** - reduce bandwidth and storage requirements. With Ultra 265 compression technology, you can store more information using less hard drive space. Ultra 265 also helps you minimize bandwidth requirements for high-resolution video and makes the remote viewing less demanding on the recorder.

# SPECIFICATIONS

## CAMERA

Sensor	1/3", 4.0 megapixel, progressive scan, CMOS
Lens	2.8mm@F1.6
Angle of view (H)	101.1°
Angle of View (V)	55.3°
Angle of View (O)	111.1°
Adjustment angle	Pan: 3° ~ 360° Tilt: 0° ~ 68° Rotate: 3° ~ 360°
Shutter	Auto/Manual, 1 - 1/100000s
Minimum Illumination	Support Easystar: Colour: 0.003Lux ( F1.6, AGC ON)
OLux with IR	IR-cut filter with auto switch (ICR)
Day/Night	IR-cut filter with auto switch (ICR)
Digital noise reduction	2D/3D DNR
S/N	>56dB
IR Range	Up to 30m (98ft) IR range
Wavelength	850nm
IR On/Off Control	Auto/Manual
Defog	Digital Defog
WDR	120dB

## VIDEO

Video Compression	Ultra 265, H.265, H.264, MJPEG
H.264 code profile	Baseline profile, Main profile, High profile
Frame Rate	Main Stream: 4MP (2688*1520), Max 30fps; 4MP (2560*1440), Max 30fps; 3MP (2304*1296), Max 30fps; 2MP (1920*1080), Max 30fps; Sub Stream: 720P (1280*720), Max 30fps; D1 (720*576), Max 30fps; 640*360, Max 30fps; 2CIF(704*288), Max 30fps; CIF(352*288), Max 30fps;
Video Bit Rate	128 Kbps-16 Mbps
9:16 Corridor Mode	Supported
OSD	Up to 4 OSDs
Privacy Mask	Up to 4 areas
ROI	Up to 8 areas
Motion Detection	Up to 4 areas

## IMAGE

White Balance	Auto/Outdoor/Fine Tune/Sodium Lamp/Locked/Auto2
Digital noise reduction	2D/3D DNR
Smart IR	Supported
Flip	Normal/Vertical/Horizontal/180°/90°Clockwise/90°Anti-clockwise
Dewarping	N/A
HLC	Supported
BLC	Supported

## NETWORK

Protocols	IPv4, IGMP, ICMP, ARP, TCP, UDP, DHCP, RTP, RTSP, RTCP, RTMP, DNS, DDNS, NTP, FTP, UPnP, HTTP, HTTPS, SMTP, SSL, 802.1x, SNMP
Compatible Integration	ONVIF (Profile S, Profile G, Profile T), API
Client	Alibi Vigilant CMS Alibi Vigilant Toolbox Alibi Vigilant Mobile
Web Browser	Plug-in required live view: IE9+, Chrome 41 and below, Firefox 52 and below Plug-in free live view: Chrome 57.0+, Firefox 58.0+, Edge 16+, Safari 11+

## STORAGE

Edge Storage	Micro SD, up to 256 GB
Network Storage	ANR,NAS(NFS)

## INTERFACE

Network	10/100M Base-TX Ethernet
---------	--------------------------

## CERTIFICATIONS

Certifications	CE: EN 60950-1 UL: UL60950-1 FCC: FCC Part 15
----------------	---

## GENERAL

Power	DC 12V±25%, PoE (IEEE 802.3af) Power consumption: Max5.5W
Dimensions (Ø x H)	109 Dia x 81mm (4.3" Dia x 3.2")
Net Weight	0.35kg (0.77lb)
Material	Metal + Plastic
Working Environment	-30°C ~ 60°C (-22°F ~ 140°F), Humidity: ≤95% RH (non-condensing)
Storage Environment	-30°C ~ 60°C (-22°F ~ 140°F), Humidity: ≤95% RH (non-condensing)
Surge Protection	4KV
Ingress Protection	IP67
Vandal Resistant	IK10
Reset Button	N/A

BRACKETS



ALI-A01-IN



ALI-CM24-IN



ALI-JB03-G-IN



ALI-JB07/WM03-G-IN



ALI-SE45-A-IN



ALI-SE24-IN



ALI-UM06-E-IN



ALI-UP06-IN



ALI-WM03-D-IN

DIMENSIONS

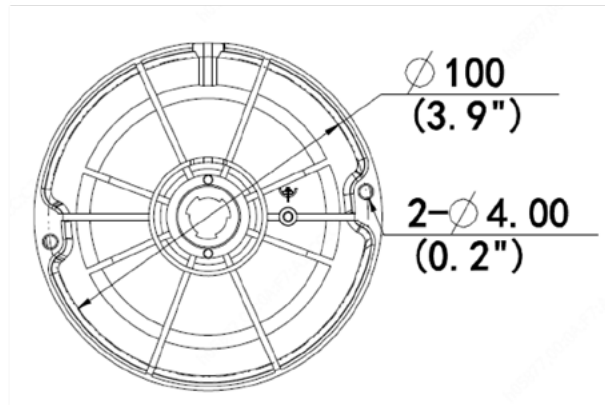
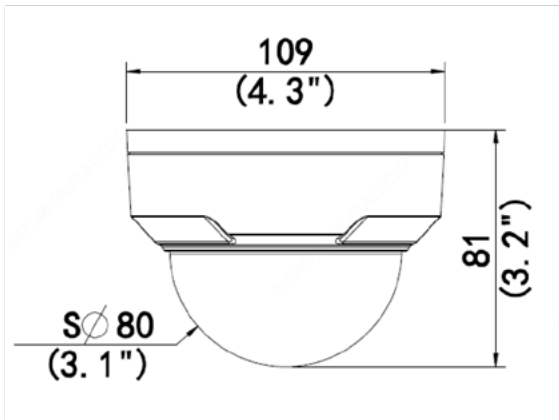



**I. SCOPE OF WORK** - ESSI will provide and install the following video equipment:

- A.** Two (2) Alibi Video day/night digital color four-megapixel network License Plate Recognition (LPR) cameras, with variable focal lenses, built-in infrared illuminators. They will be set up to view and record activity at the following building locations:
  - 1. N Fillmore Street entrance to rear lot near Building 2807
  - 2. Arlington Boulevard entrance to rear lot near Building 2503
- B.** Six (6) Alibi Video day/night digital color five-megapixel cameras with vandal resistant mini-dome housings, wide angle fixed lenses and built-in infrared illuminators. They will be set up to view and record activity at the following building locations:
  - 1. Building 2709, two (2) cameras on each corner, providing crisscrossing views of the rear parking area and the dumpster corrals.
  - 2. Building 2611, two (2) cameras on each corner, providing crisscrossing views of the rear parking area and the dumpster corrals.
  - 3. Building 2509, two (2) cameras on each corner, providing crisscrossing views of the rear parking area and the dumpster corrals.
- C.** One (1) Alibi Video 32-channel Network Video Recorder (NVR) with an eight terabyte hard drive, rack mounted in the lower level meeting room area.
- D.** One (1) Uninterruptible Power Supply (UPS) installed near the NVR, as protection from electrical spikes and power drops.
- E.** Four (4) network switches with Power over Ethernet (PoE). Cameras will be wired to the switches using a single Cat6 wire. Switches to be wall mounted in enclosures in the electrical rooms of the following buildings:
  - 1. 2807 (meeting room area)
  - 2. 2709 storage area
  - 3. 2611 storage area
  - 4. 2509 storage area
- F.** Six (6) wireless transmission RF line-of-sight antennas, used to send the video data between buildings, in lieu of digging trenches and burying wire. Antennas will be wired to the network switches. See the attached device location sketch for the antenna layout and design.
- G.** All necessary labor and wire to install and program is included.
- H.** All necessary conduit to protect exterior wiring is included.
- I.** On-site system operation training following installation. Additional training and technical support will be provided at no charge when needed, throughout the term of the warranty and any subsequent service plan.

January 24<sup>th</sup>, 2022

Initials 

*The data contained in this document has been submitted in confidence, contains privileged information, is proprietary in nature and thus may not be reproduced or disseminated without the written consent of Electronic Security Services, Inc.*

## II. SYSTEM OPERATION:

### Cameras and Lenses

The cameras and lenses designed for your application are specified by ESSI based on changing light conditions, climate changes, and your field of view requirements. Based on this, ESSI recommends Alibi Video four-megapixel color network cameras. The cameras have built-in digital infrared illuminators, which help the cameras see images even in low light, and Wide Dynamic Range, compensating for severe backlight. The result is very sharp images with high clarity for the end-user.

### Network Video Recorder

Your 32-channel Network Video Recorder (NVR) will provide the capability of recording all cameras within the system. Camera configuration will be based on consultation with management. Each camera will be set up to record constantly at a low frame rate, then automatically increase the frame rate when motion is detected within the field of view of that specific camera, saving unnecessarily used memory. The proposed hard drive should provide about 30 days of recorded images, depending on the activity and settings. Previously recorded events can be easily searched, and copied to an external storage device. Cameras can also be viewed or reviewed remotely from office PC's, laptops, or smartphones on the free Alibi Video app for Androids, iPads, iPhones, etc. The system will require a high-speed Internet connection at the NVR locations (provided by others) for remote access to the video security software.

## III. CLARIFICATIONS:

- A. OPERATION:** The Customer shall be responsible to periodically evaluate the system to ensure satisfactory operation.
- B. REPAIRS:** The Customer shall be responsible for patching and/or repair/painting of holes exposed during installation.
- C. TRAINING:** System training is complimentary as often as required throughout the term of the warranty and any subsequent service plan.
- D. INSTALLATION SPACE:** The Customer shall provide adequate space for the installation of the control equipment. The space must have an operating environment suitable for the specified equipment.
- E. LIGHTING:** The Customer shall be responsible for providing suitable white lighting to optimize system performance.

January 24<sup>th</sup>, 2022

Initials 

*The data contained in this document has been submitted in confidence, contains privileged information, is proprietary in nature and thus may not be reproduced or disseminated without the written consent of Electronic Security Services, Inc.*



- F. WIRELESS:** ESSI assumes no liability for wireless interference or obstructions that may be present at the site during the time of the installation. Any interference or obstructions that adversely affect system operation will be reported to the property manager upon discovery and alternative methods of transmission will be discussed. Changes to the system design as outlined in the scope of work due to interference or obstruction of wireless transmission will result in an above contract cost change order.
- G. PARKING:** The Customer shall be responsible for providing ESSI parking at the facility for the duration of the project.
- H. INTERNET:** The customer will be responsible for having its Internet provider install a high-speed Internet line at the location of the DVR in order to utilize the remote video management software tools.
- I. PERMITS:** The Customer will be responsible for all direct and indirect costs of obtaining permits (if required), including: Permit cost, ESSI engineered drawings and labor, Master electrician costs, travel time to Permit Office, and any on-site inspection time with the Authority Having Jurisdiction (AHJ).

**IV. INSTALLATION:**

- A.** The work includes all necessary cable, wiring, connectors, terminal strips, batteries, transformers, terminations, and testing required to provide a complete professional operating system.
- B.** A Certificate of Insurance of Workmen's Compensation shall be provided upon request.
- C.** All work, under this proposal includes techniques, sequences, procedures, and means for coordination of the work.
- D.** All work to be supervised and tested by the Installation Manager or other equally qualified ESSI personnel.

January 24<sup>th</sup>, 2022

Initials 

*The data contained in this document has been submitted in confidence, contains privileged information, is proprietary in nature and thus may not be reproduced or disseminated without the written consent of Electronic Security Services, Inc.*

**V. WARRANTY**

- A.** Electronic Security Services, Inc. (ESSI) guarantees that all supplied materials and workmanship will be serviceable and will perform dependably for a period of one year (ninety days for lock and door hardware). The warranty period shall commence when the customer has beneficial use of the system, or upon installation acceptance, whichever occurs first.
- B.** ESSI will be responsible for maintaining all supplied equipment in good, efficient operating condition and will supply all labor and parts necessary to repair the systems. The Customer shall be responsible to periodically evaluate the system to ensure satisfactory operation.
- C.** ESSI reserves the right to invoice for parts and labor necessitated due to external intervening causes such as vandalism, unauthorized service, acts of God, etc.
- D.** Equipment outages should be reported by an on-site manager or authorized representative. ESSI will respond to all requests for service on a priority basis, at no additional charge, Monday through Friday during normal business hours. When notification is received before 10 A.M., ESSI will dispatch one or more technicians to arrive at the equipment location before the close of the business day. When notification is received after 10 A.M., technicians will be dispatched before the close of business on the next business day. Service after normal business hours and on weekends is available at a premium rate.
- E.** Equipment will be serviced and returned to full operation on the day serviced whenever possible. In the event the equipment cannot be repaired in that time frame, ESSI will notify the on-site manager or representative. ESSI service technicians will report to the on-site manager or representative and sign in, if required, prior to starting any work. Each ESSI service call is recorded on an ESSI form, a copy of which will be furnished to the on-site manager upon job completion.

January 24<sup>th</sup>, 2022

Initials 

*The data contained in this document has been submitted in confidence, contains privileged information, is proprietary in nature and thus may not be reproduced or disseminated without the written consent of Electronic Security Services, Inc.*

---

**VI. PRICING AND TERMS:**

Forty percent (40%) of the contract cost will be invoiced upon acceptance of the agreement.  
The balance is due in upon project completion and installation acceptance.

**Total Investment:** Twenty-Three Thousand Three Hundred Sixty-Eight Dollars  
(\$23,368.00)

January 24<sup>th</sup>, 2022

Initials 

*The data contained in this document has been submitted in confidence, contains privileged information, is proprietary in nature and thus may not be reproduced or disseminated without the written consent of Electronic Security Services, Inc.*

**VII. GENERAL TERMS AND CONDITIONS:**

- A. It is understood that ESSI is not an insurer and that insurance, if any, shall be obtained by the customer and that amounts payable to ESSI hereunder are based upon the value of the services, and the scope of liability as herein set forth are unrelated to the value of the customer's property or others located in the customer's premises. ESSI makes no guarantee or warranty, including implied warranty of merchandise or fitness, that the system or services supplied, will avert or prevent occurrences or the consequences therefrom, which the system or service is designed to detect. It is impractical and extremely difficult to fix the actual damages, if any, which may proximately result from failure on the part of ESSI to perform any of its obligations hereunder. The customer does not desire this contract to provide for full liability of ESSI, and agrees that ESSI shall be exempt from loss or damage due directly or indirectly to occurrences, or consequences therefrom, which the service or system is designed to detect or avert; that if ESSI should be found liable for loss or damage due to a failure of service or equipment in any respect, its liability shall be limited to \$100.00, as liquidated damages and not as a penalty, as the exclusive remedy, and that the provisions of this paragraph shall apply if loss or damage, irrespective of cause or origin, results directly or indirectly to person or property from performance or nonperformance of obligations imposed by this contract or from negligence, active or otherwise, of ESSI, its agents or employees. If the customer desires insurance to cover any liability over and above this, it shall be the obligation of the customer to obtain such insurance at its own expense.
- B. LATE PAYMENT CHARGES: Payments not received within ten (10) days of the due date will incur a service charge of ten dollars (\$10.00) per month or three percent (3%) per month, whichever is greater.
- C. COLLECTION: The Buyer shall pay ESSI all costs and expenses including any attorney's fees or collection agency fees and court costs whether this Agreement is placed in the hands of either for collection, or if such costs or expenses are incurred by ESSI in exercising any of its rights hereunder.
- D. DEFAULT: If the Buyer fails to pay any installment payment or any other amounts herein provided within ten (10) days after the same is due and payable, or if the Buyer fails to perform any other provision hereof within ten (10) days after ESSI shall have demanded payment in writing performance thereof, or if any proceeding in bankruptcy, receivership or insolvency shall be commenced by or against the Buyer or its property, or if the Buyer makes any assignment for the benefit of its creditors, or if a meeting of creditors is called by the Buyer to discuss its financial obligations, or if judicial liens have been secured against the Buyer and/or its property and not released within a period of fifteen (15) days, or if ESSI shall reasonably feel that the Buyer is no longer financially responsible, ESSI shall have the right but not the obligation to exercise any one or more of the following remedies:
1. To accelerate the terms of this Agreement and declare the full amount of the Agreement immediately due and payable.
  2. To take possession of any or all of the equipment, wherever it may be located without demand or notice, without any court order or other process of law, and without incurring any liability for any damages occasioned by such taking of possession.
  3. To sell any or all of the equipment at public or private sale for cash or on credit and to recover from the Buyer all costs of taking possession, storing, repairing, and selling equipment.
  4. In addition, the Buyer shall pay ESSI all costs and expenses including any attorney's fees if this Agreement is placed in the hands of an attorney for collection, in exercising any of its rights hereunder.
  5. ESSI reserves the right to place mechanics liens as provided by law in the jurisdiction where the property is, or may be, located.
- E. The Buyer hereby acknowledges that he/she has been advised that there are other types of security systems supplied by ESSI that may be more thorough and advantageous, desirable or serviceable, and the Buyer agrees that he/she has selected and hereby approves the system described in this document.
- F. The Customer shall be responsible to periodically evaluate the system to ensure satisfactory operation.
- G. All prices are firm for 45 days from the date of this proposal.

January 24<sup>th</sup>, 2022

Initials 

*The data contained in this document has been submitted in confidence, contains privileged information, is proprietary in nature and thus may not be reproduced or disseminated without the written consent of Electronic Security Services, Inc.*