

SEAL

APPROVALS	DATE
DESIGN TEAM SUPERVISOR	
CHIEF T.E. & O. BUREAU	
TRAFFIC SIGNAL ENGINEER	
DEPARTMENT OF TRANSPORTATION	

REVISIONS	DATE

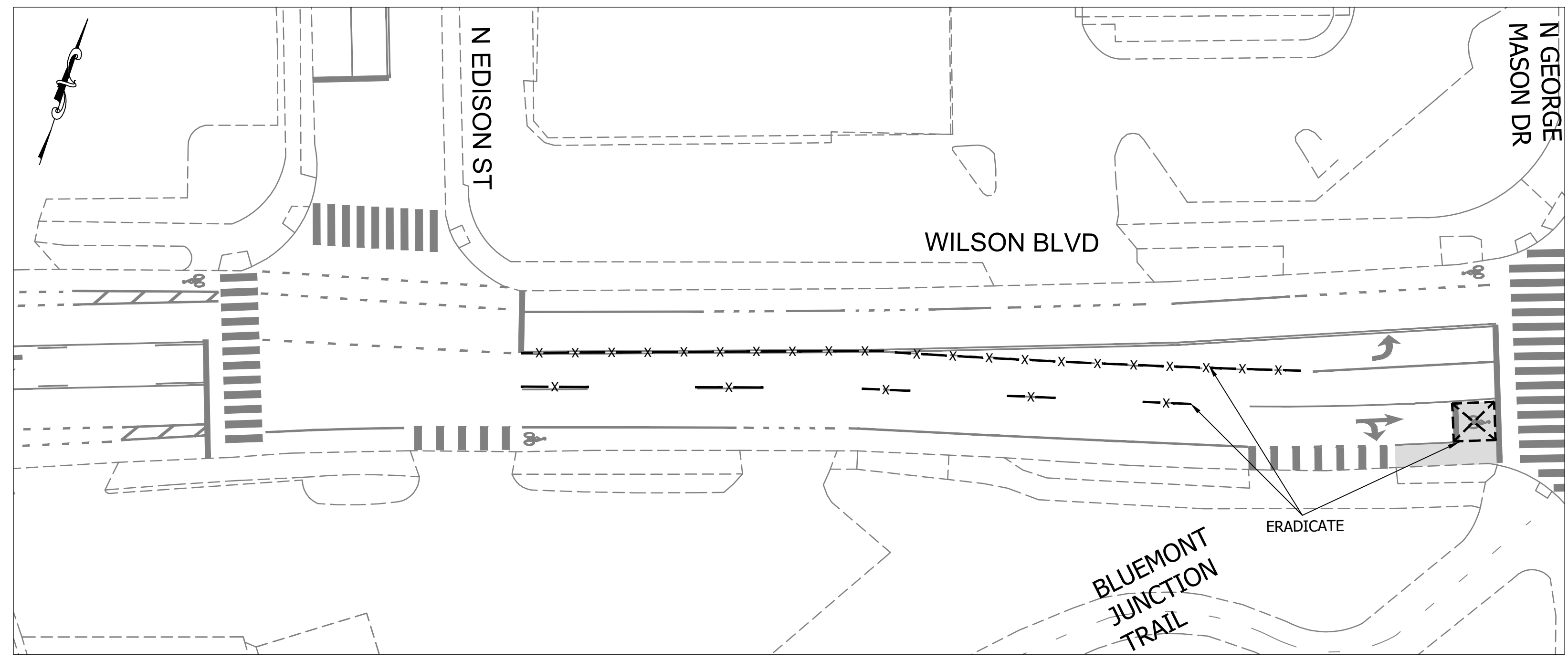

STANDARD PAVEMENT MARKING LEGEND			
A	TYPE B CLASS 1	WHITE 4" WIDTH	PARKING LANES, EDGE LINES, LANE LINES
B	TYPE B CLASS 1	WHITE 4" WIDTH 10' LONG 30" SPACING	DASHED LANE LINES
C	TYPE B CLASS 1	WHITE 4" WIDTH, 2' LONG, 10' SPACING	LANE TRANSITIONS, TURN LANE SKIPS
D	TYPE B CLASS 1	WHITE 18" WIDTH	STOP BARS
E	TYPE B CLASS 1	WHITE 24" WIDTH	CONTINENTAL CROSSWALKS, VDOT STOP BARS
F	TYPE B CLASS 1	WHITE 6" WIDTH	TURN LANES, TRANSVERSE CROSSWALKS, BIKE LANES
G	TYPE B CLASS 1	YELLOW 4" WIDTH, 10' LONG, 30" SPACING	DIVIDED TRAFFIC, TWO WAY TURN LANES
H	TYPE B CLASS 1	YELLOW 4" WIDTH	EDGELINES
I	TYPE B CLASS 1	YELLOW 4" WIDTH, DOUBLE LINE, 4" SPACING	CENTERLINES
J	TYPE B CLASS 1	WHITE 6" WIDTH, 10' SPACING @ 45°	HATCH LINES, SAFETY ZONES
K	TYPE B CLASS 1	WHITE SINGLE ARROW	TURN LANES ARROWS
L	TYPE B CLASS 1	WHITE COMBINATION ARROW	TURN LANES ARROWS
M	TYPE B CLASS 1	WHITE 8" LETTERS	PAVEMENT MARKING LETTERS (STOP, YIELD, BUS, ONLY etc)
N	TYPE B CLASS 1	WHITE 6" WIDTH, 2' LONG, 10' SPACING	LANE TRANSITIONS
O	TYPE B CLASS 1	WHITE 12" WIDTH, 20' SPACING @ 45°	GORE MARKINGS
P	TYPE B CLASS 1	YELLOW 8" WIDTH @ 45°	GORE MARKINGS
Q	TYPE B CLASS 1	WHITE 6" WIDTH, 2' LONG, 4' SPACING	LANE TRANSITIONS
R	TYPE B CLASS 1	WHITE 4" WIDTH, DOUBLE LINE, 4' SPACING	CURB EXTENSIONS
S	TYPE B CLASS 1	YELLOW 4" WIDTH, 2' LONG, 4' SPACING	LANE TRANSITIONS
T	TYPE B CLASS 1	YELLOW 6" WIDTH, 2' LONG 4' SPACING	LANE TRANSITIONS
U	TYPE B CLASS 1	YELLOW 6" WIDTH, 10' SPACING @ 45°	HATCH LINES, SAFETY ZONES
V	TYPE B CLASS 1	YELLOW 6" WIDTH, DOUBLE LINE 2' LONG 4' SPACING	LANE TRANSITIONS, DASHED CENTERLINES

- PAVEMENT MARKING NOTES:**
- STREET WIDTH MEASUREMENTS ARE FROM FACE OF CURB TO FACE OF CURB. LANES ARE MEASURED FROM CENTER OF MARKING TO CENTER OF MARKING .
 - CONTACT TE&O CONSTRUCTION MANAGER OR HIS DESIGNEE AT 703-228-6598 OR (571) 437-1077 TO APPROVE MARKING LAYOUT 48 HRS. PRIOR TO INSTALLATION OF MARKING.
 - PAVEMENT MARKINGS TO BE IN ACCORDANCE WITH THE FOLLOWING:
 A.) THE MANUAL ON UNIFORM TRAFFIC CONTROL DEVICES.
 B.) ARLINGTON COUNTY PAVEMENT MARKING SPECIFICATIONS.
 - ALL MARKINGS SHALL BE THERMOPLASTIC PER ARLINGTON COUNTY MARKING STANDARDS UNLESS OTHERWISE NOTED.
 - SHARED LANE MARKINGS SHALL BE PLACED IN CENTER OF TRAVEL LANE.
 - FOR DETAILS SEE ARLINGTON COUNTY PAVEMENT MARKING SPECIFICATIONS.

- SIGN NOTES:**
- FOR ALL SIGN POSTS PLACED IN CONCRETE USE 7 GAUGE HEAVY DUTY ANCHOR (30"x2.50") WITH HARDWARE FOR 2" POST. USE 3/8" CORNER BOLT WITH FLANGED NUT AND 3/8" DRIVER RIVET WITH WASHER.
 - CONTACT TE&O CONSTRUCTION MANAGER OR HIS DESIGNEE AT 703-228-6598 OR 571-437-1077 48 HRS PRIOR TO POURING CONCRETE. ALTERNATIVE CONTACT AT 703-228-3788 OR 571-414-7497.

LEGEND	
EXISTING	PROPOSED

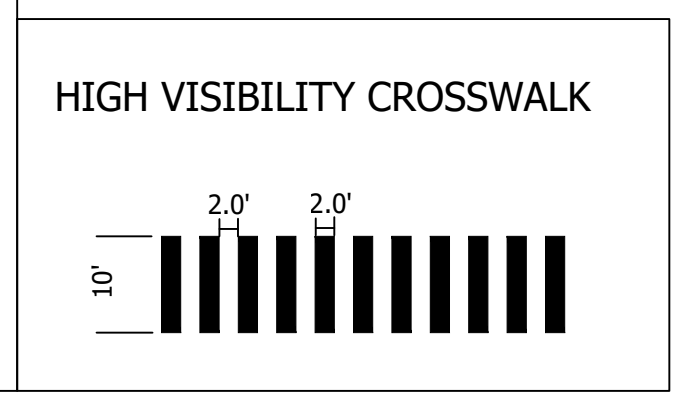

WILSON BOULEVARD
 FROM: NORTH GEORGE MASON DRIVE
 TO: NORTH GLEBE ROAD
ERADICATION PLAN

DESIGNED: CS
 DRAWN: CS
 CHECKED: KC

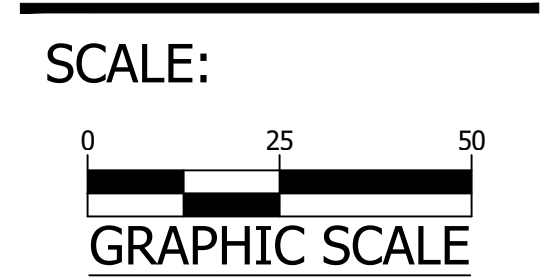

SEAL

APPROVALS	DATE
DESIGN TEAM SUPERVISOR	
CHIEF T.E. & O. BUREAU	
TRAFFIC SIGNAL ENGINEER	
DEPARTMENT OF TRANSPORTATION	
REVISIONS	DATE

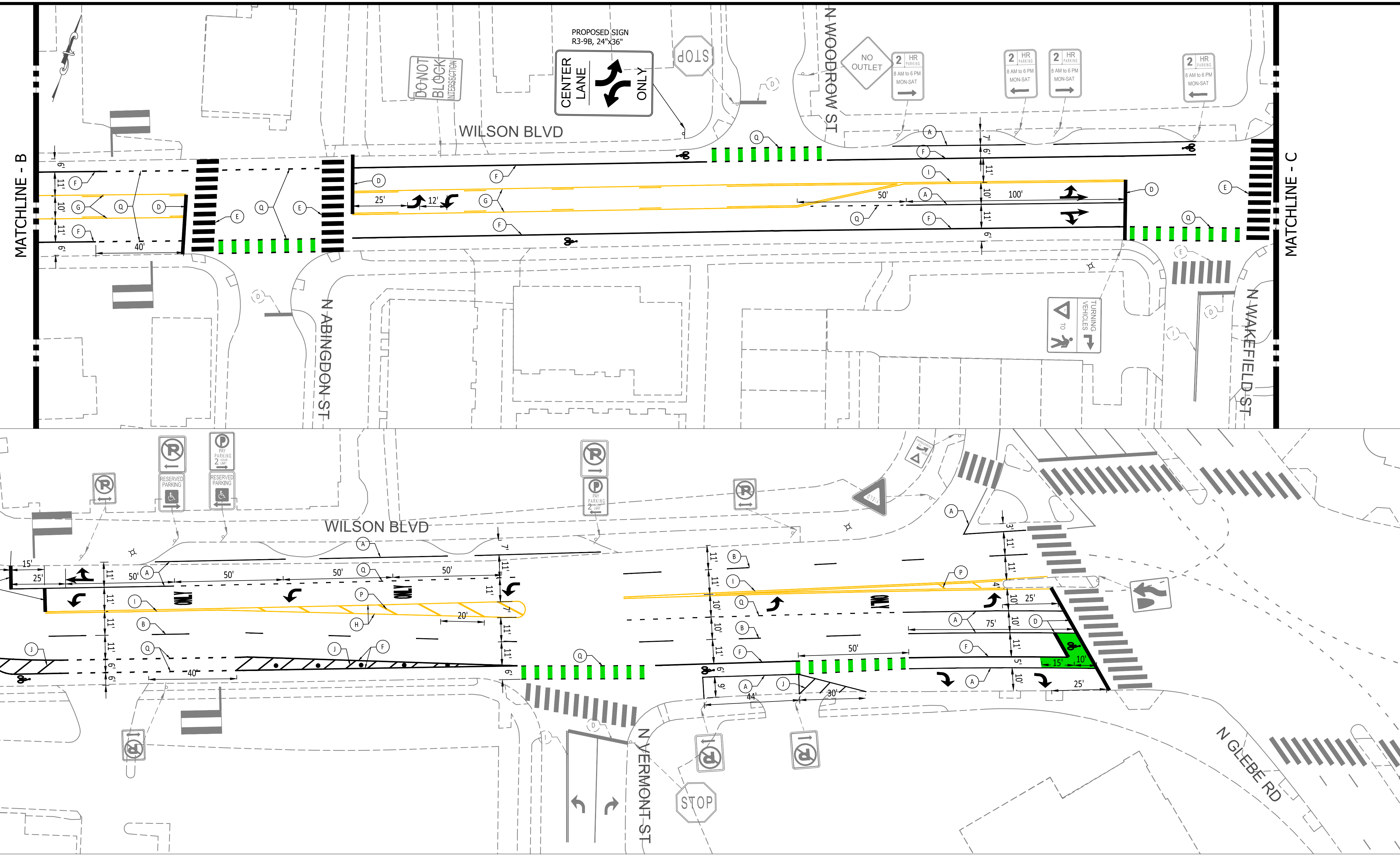

STANDARD PAVEMENT MARKING LEGEND

Symbol	Type B Class	Description	Application
A	TYPE B CLASS 1	WHITE 4" WIDTH	PARKING LANES, EDGE LINES, LANE LINES
B	TYPE B CLASS 1	WHITE 4" WIDTH 10' LONG 30' SPACING	DASHED LANE LINES
C	TYPE B CLASS 1	WHITE 4" WIDTH, 2' LONG, 10' SPACING	LANE TRANSITIONS, TURN LANE SKIPS
D	TYPE B CLASS 1	WHITE 18" WIDTH	STOP BARS
E	TYPE B CLASS 1	WHITE 24" WIDTH	CONTINENTAL CROSSWALKS, VDOT STOP BARS
F	TYPE B CLASS 1	WHITE 6" WIDTH	TURN LANES, TRANSVERSE CROSSWALKS, BIKE LANES
G	TYPE B CLASS 1	YELLOW 4" WIDTH, 10' LONG, 30' SPACING	DIVIDED TRAFFIC, TWO WAY TURN LANES
H	TYPE B CLASS 1	YELLOW 4" WIDTH	EDGE LINES
I	TYPE B CLASS 1	YELLOW 4" WIDTH, DOUBLE LINE, 4" SPACING	CENTER LINES
J	TYPE B CLASS 1	WHITE 6" WIDTH, 10' SPACING @ 45°	HATCH LINES, SAFETY ZONES
K	TYPE B CLASS 1	WHITE SINGLE ARROW	TURN LANES ARROWS
L	TYPE B CLASS 1	WHITE COMBINATION ARROW	TURN LANES ARROWS
M	TYPE B CLASS 1	WHITE 8" LETTERS	PAVEMENT MARKING LETTERS (STOP, YIELD, BUS, ONLY etc)
N	TYPE B CLASS 1	WHITE 6" WIDTH, 2' LONG, 10' SPACING	LANE TRANSITIONS
O	TYPE B CLASS 1	WHITE 12" WIDTH, 20' SPACING @ 45°	GORE MARKINGS
P	TYPE B CLASS 1	YELLOW 8" WIDTH @ 45°	GORE MARKINGS
Q	TYPE B CLASS 1	WHITE 6" WIDTH, 2' LONG, 4' SPACING	LANE TRANSITIONS
R	TYPE B CLASS 1	WHITE 4" WIDTH, DOUBLE LINE, 4" SPACING	CURB EXTENSIONS
S	TYPE B CLASS 1	YELLOW 4" WIDTH, 2' LONG, 4' SPACING	LANE TRANSITIONS
T	TYPE B CLASS 1	YELLOW 6" WIDTH, 2' LONG 4' SPACING	LANE TRANSITIONS
U	TYPE B CLASS 1	YELLOW 6" WIDTH, 10' SPACING @ 45°	HATCH LINES, SAFETY ZONES
V	TYPE B CLASS 1	YELLOW 6" WIDTH, DOUBLE LINE 2' LONG 4' SPACING	LANE TRANSITIONS, DASHED CENTER LINES

PAVEMENT MARKING NOTES:

- STREET WIDTH MEASUREMENTS ARE FROM FACE OF CURB TO FACE OF CURB. LANES ARE MEASURED FROM CENTER OF MARKING TO CENTER OF MARKING.
- CONTACT TE&O CONSTRUCTION MANAGER OR HIS DESIGNEE AT 703-228-6598 OR (571) 437-1077 TO APPROVE MARKING LAYOUT 48 HRS. PRIOR TO INSTALLATION OF MARKING.
- PAVEMENT MARKINGS TO BE IN ACCORDANCE WITH THE FOLLOWING:
 - A.) THE MANUAL ON UNIFORM TRAFFIC CONTROL DEVICES.
 - B.) ARLINGTON COUNTY PAVEMENT MARKING SPECIFICATIONS.
- ALL MARKINGS SHALL BE THERMOPLASTIC PER ARLINGTON COUNTY MARKING STANDARDS UNLESS OTHERWISE NOTED.
- SHARED LANE MARKINGS SHALL BE PLACED IN CENTER OF TRAVEL LANE.
- FOR DETAILS SEE ARLINGTON COUNTY PAVEMENT MARKING SPECIFICATIONS.

SIGN NOTES:

- FOR ALL SIGN POSTS PLACED IN CONCRETE USE 7 GAUGE HEAVY DUTY ANCHOR (30"x2.50") WITH HARDWARE FOR 2" POST. USE 3/8" CORNER BOLT WITH FLANGED NUT AND 3/8" DRIVER RIVET WITH WASHER.
- CONTACT TE&O CONSTRUCTION MANAGER OR HIS DESIGNEE AT 703-228-6598 OR 571-437-1077 48 HRS PRIOR TO POURING CONCRETE. ALTERNATIVE CONTACT AT 703-228-3788 OR 571-414-7497.

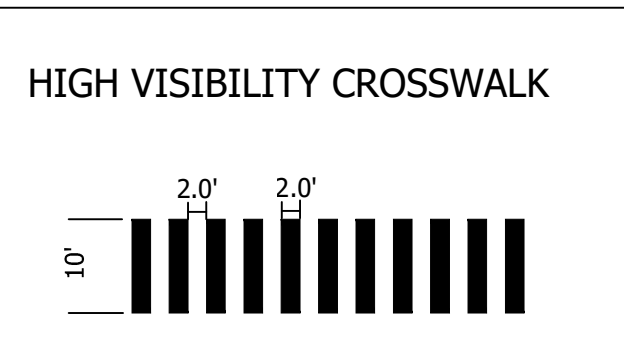

LEGEND

EXISTING	PROPOSED

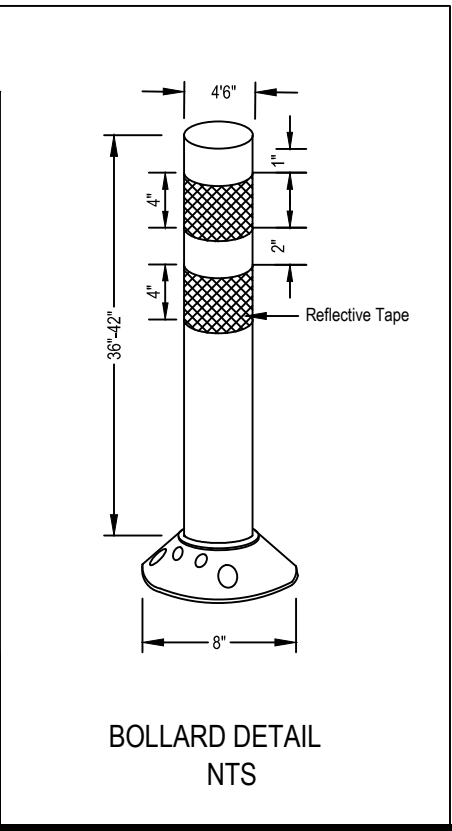
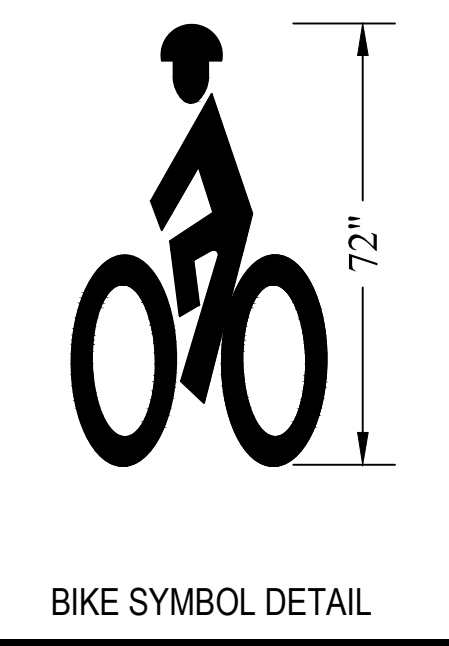

WILSON BOULEVARD
 FROM: NORTH GEORGE MASON DRIVE
 TO: NORTH GLEBE ROAD

SIGNING AND MARKING PLAN

DESIGNED: CS
 DRAWN: CS
 CHECKED: KC

SCALE:
 0 25 50
 GRAPHIC SCALE

SHEET 3 OF 3