

STRUCTURAL

The Contractor warrants the finished project to be constructed in accordance with industry standards and shall adhere to all local codes and regulations. Do not scale drawings, numerical dimensions and notes supersede scaled dimensions, consult architect for dimensions not indicated or in error.

- **Notify "Miss Utility" and other appropriate parties prior to work to verify locations of all underground utilities.**
- All existing conditions shall be verified by the contractor and any discrepancies with the contract documents shall be brought to the attention of the Architect/Engineer for resolution.
- Design and construction shall conform to all zoning and building codes and regulations as required by the code enforcement agency having jurisdiction over the building site.
- Design Live Loads are: WHEN APPLICABLE

o Roof LL 30 PSF, DL 15 PSF N/A

CARPENTRY

- A. Lumber shall be Southern Pine #2, or better, and shall be kept dry at the site with the following minimum design values: Fb = 1,000 PSI, Fv = 75 PSI, Fc = 675 PSI. E = 1,300,000 PSI.
- B. Wood headers shall be (2)2 x 10 for all openings
- C. LVL Lumber and plywood truss joist shall be manufactured by Truss Joist Company or equal. LVL lumber shall have the following minimum design properties: Fb = 2,800 PSI, Fv = 285 PSI, Fc = 2,700 PSI, E = 2,000,000 PSI
- D. Joists and beams not having any direct bearing shall have properly sized 16 gage hangers manufactured by Simpson or equal.
- All beams comprised of two members shall be nailed together with two rows of 16d nails @12" o.c. for each ply, unless noted otherwise. Posts comprised of more than one member shall be glued and nailed together. All beams comprised of 3 or more members shall be through bolted with 1/2" dia bolts @ 12" o.c., staggered.
- F. Provide 2x3x2" bridging or solid blocking at mid-span of all spans greater than 8'-0"
- H. All OSB flooring shall be glued and screwed.
- I. Bearing walls shall have mid-height blocking.
- J. Posts shall be carried down to supporting beams, footings or foundation walls. Where posts are interrupted by floor framing, solid end grain blocking shall be supplied for continuous bearing of post.
- K. All wall plates shall have mid-height blocking.
- L. All new sub-floor to be 23/32 tongue and groove Oriented Strand Board.
- M. All new roof sheathing to be 7/16" Oriented

- **The Sub-grade should be compacted/ tamped prior to placement of the aggregate,**
- **The backfill material shall be one of the following options:**
 - o Single size of the same bedding material to be compacted into lifts of 8 inch each.
 - o Flowable concrete.
 - o Premix Cement and Sand (ratio of 1:16) , assuming the unit weight of Concrete 150 PCF
- **Reinforcement and Bond Beam: The perimeter of the pool shall have a bond beam of 8 inches min depth with 2# 4 continuous reinforcement.**
- **Installation shall be in accordance to the Manufacturer recommendation.**
- **A safety fence should be install per the county/locality requirements.**

STRUCTURA STEEL

- A. Structural steel and angles shall conform to ASTM A-36. Steel pipe shall be ASTM A- 501 and A-53 w/ Fy=36ksi. Tubes shall be A500 Gr B with Fy = 46 ksi. Connections shall be capable of supporting allowable uniform load stress of 24 ksi. Bolted field connection shall be 3/4"0 high strength bolts meeting ASTM Spec. A-325. Provide welded connections typically unless otherwise indicated.
- B. Structural steel shall have minimum strength, Fy=36 ksi.
- C. Welds shall comply with AWS DI.1-80.
- D. Connections shall be AISC Standard.
- E. Provide base plate for all structural steel beams bearing on concrete or masonry.
- F. For. All columns to be 3 1/2" AISC steel columns
- G. Knee-bracing Shall be installed at each post beams location or 6x6 knee bracing at end posts and both sides of every other interior post., and shall be

- Arlington County
- The material to be used should be in accordance with HALRB
- The construction and design in accordance with 2018 VRBC and IBC
- Details Drawing include the followings :
 - o Overall dimensions of the footprint,
 - o Dimensions of the height against the building and the slope of the roof,
 - o Rafter sizes and Spacing ,
 - o Framing Plans and Rafters details
 - o Columns location and sizes
 - o Foundation Plans and attachment details
 - o Elevations

Vicinity Map

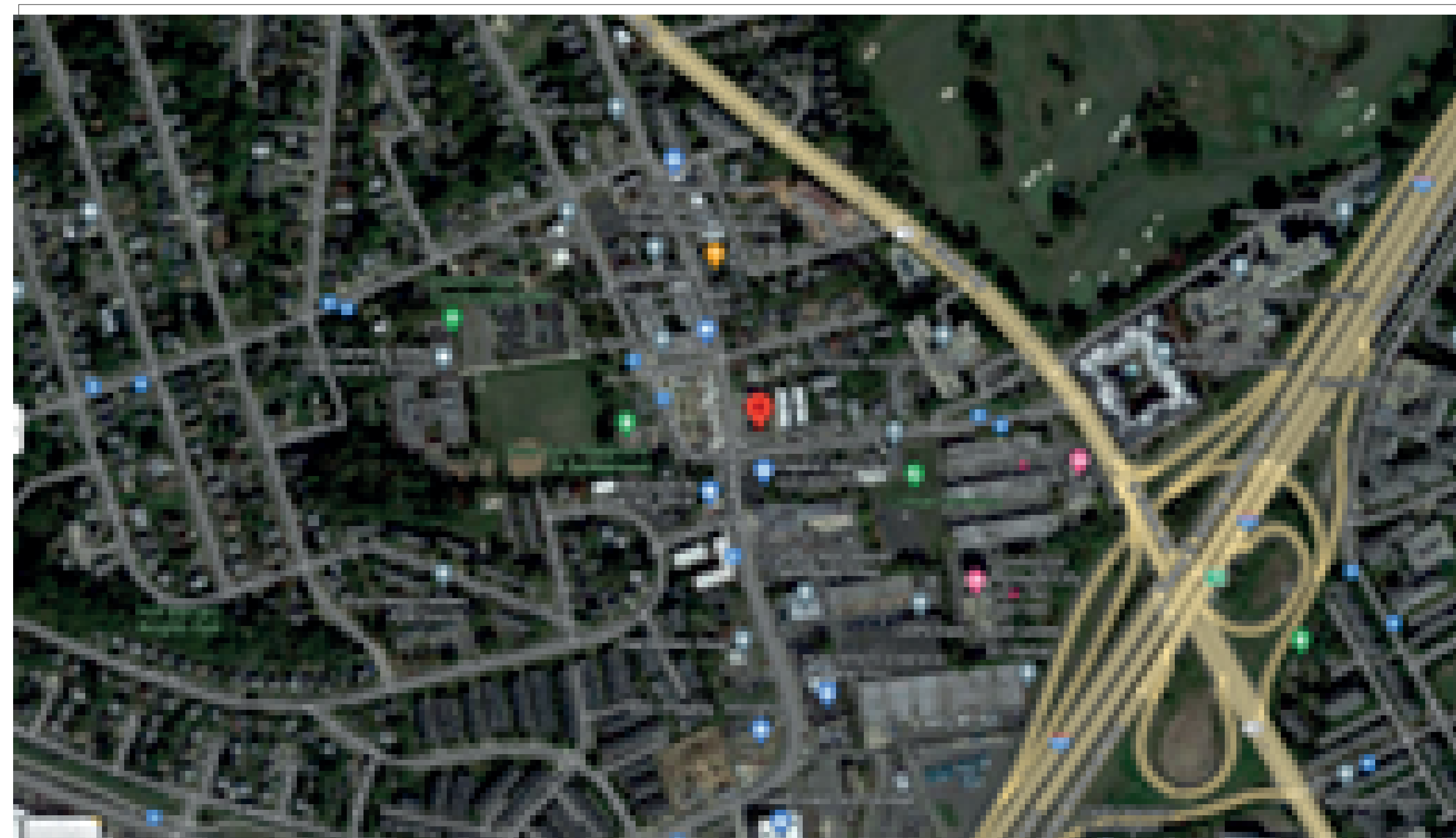

Scope of Work

Proposed Pergola along the side of the building due to the current demand on outdoor seating

Drawing Index

- C-001 COVER SHEET
- A-100 SITE PLAN
- A-101 PROPOSED PERGOLA PLAN
- A-102 PROPOSED WEST AND SOUTH ELEVATION
- S-101 PROP FOUNDATION PLANS
- S-102 ROOF FRAMING PLAN
- S-103 Footing and Connection Details

PERGOLA ADDITION 2415 SHIRLINGTON RD, VA 22206

MTES ENGINEERING SERVICES
11091 Molly Pitcher Circle
703 606 3386
MTEseng@outlook.com

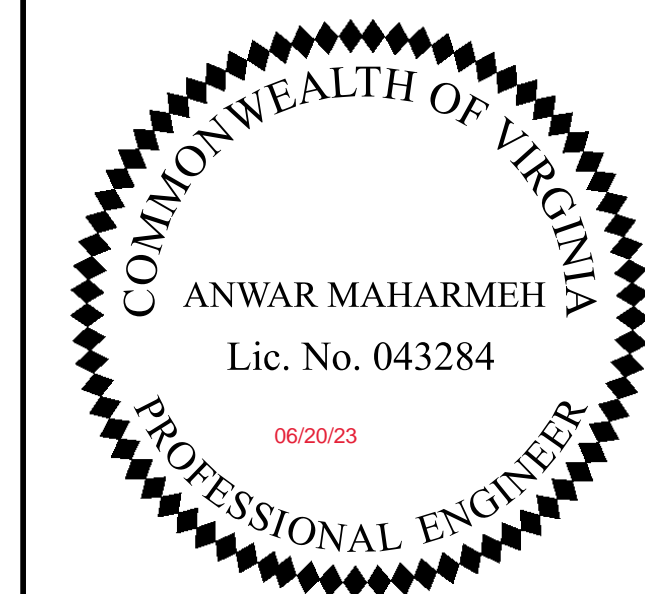

Anwar Maharmeh

No	Description	Date

Description
COVER SHEET

C-001

Project Number
Date 06-14-2022
Drawn By
Checked By

Scale **NTS**

PERGOLA ADDITION
2415 SHIRLINGTON RD,
VA 22206

MTE ENGINEERING SERVICES
11091 Molly Pitcher Circle
703 606 3386
MTEseng@outlook.com

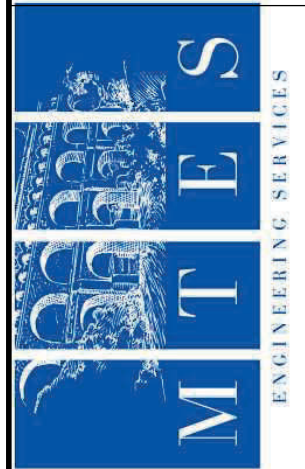

Anwar Maharmeh

No	Description	Date

Description
PERGOLA PLAN

A-101

Project Number
Date 06-12-2023
Drawn By
Checked By

Scale

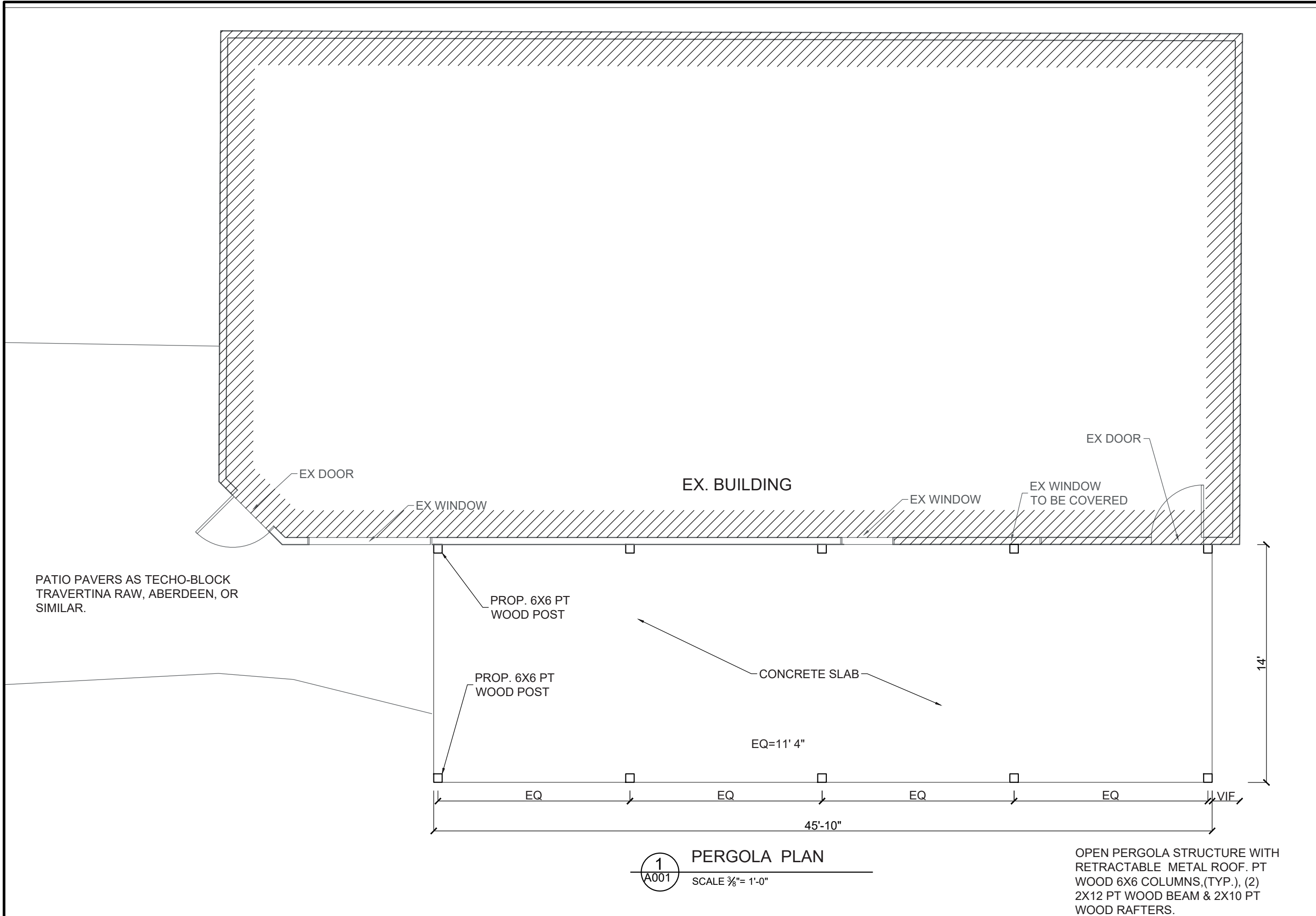

1
A001 **PERGOLA PLAN**
SCALE 3/8" = 1'-0"

OPEN PERGOLA STRUCTURE WITH
RETRACTABLE METAL ROOF. PT
WOOD 6X6 COLUMNS,(TYP.), (2)
2X12 PT WOOD BEAM & 2X10 PT
WOOD RAFTERS.

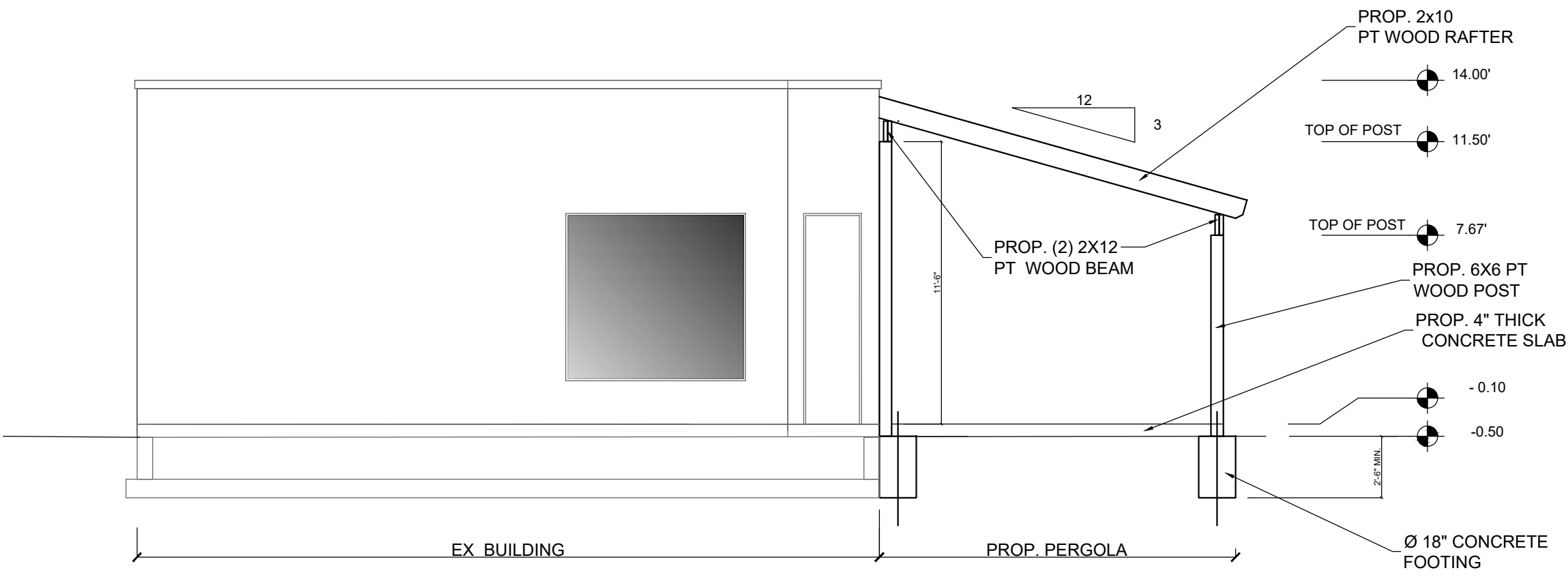

2
A002 WEST ELEVATION
SCALE 3/8" = 1'-0"

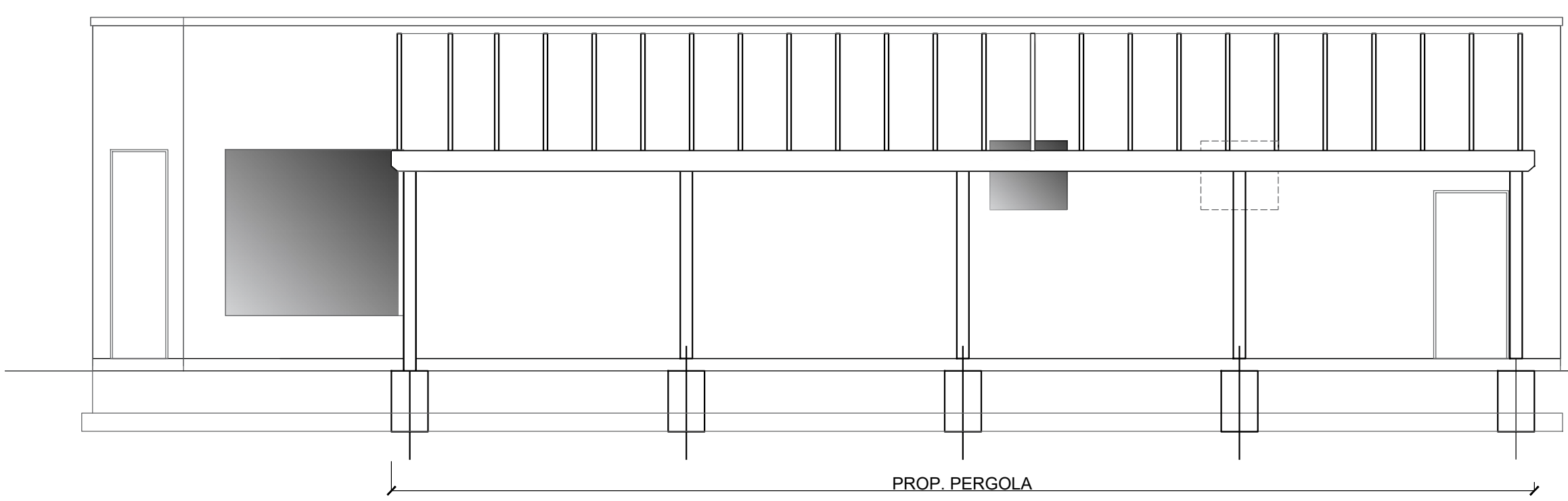

1
A002 SOUTH ELEVATION
SCALE 3/8" = 1'-0"

PERGOLA ADDITION
2415 SHIRLINGTON RD,
VA 22206

MTES ENGINEERING SERVICES
11091 Molly Pitcher Circle
703 606 3386
MTEseng@outlook.com

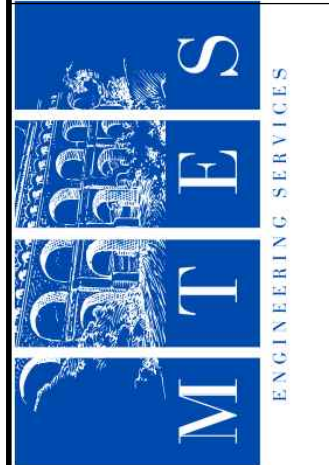

Anwar Maharmeh

No	Description	Date

Description
ELEVATIONS

A-102

Project Number
Date 06-12-2023
Drawn By
Checked By

Scale

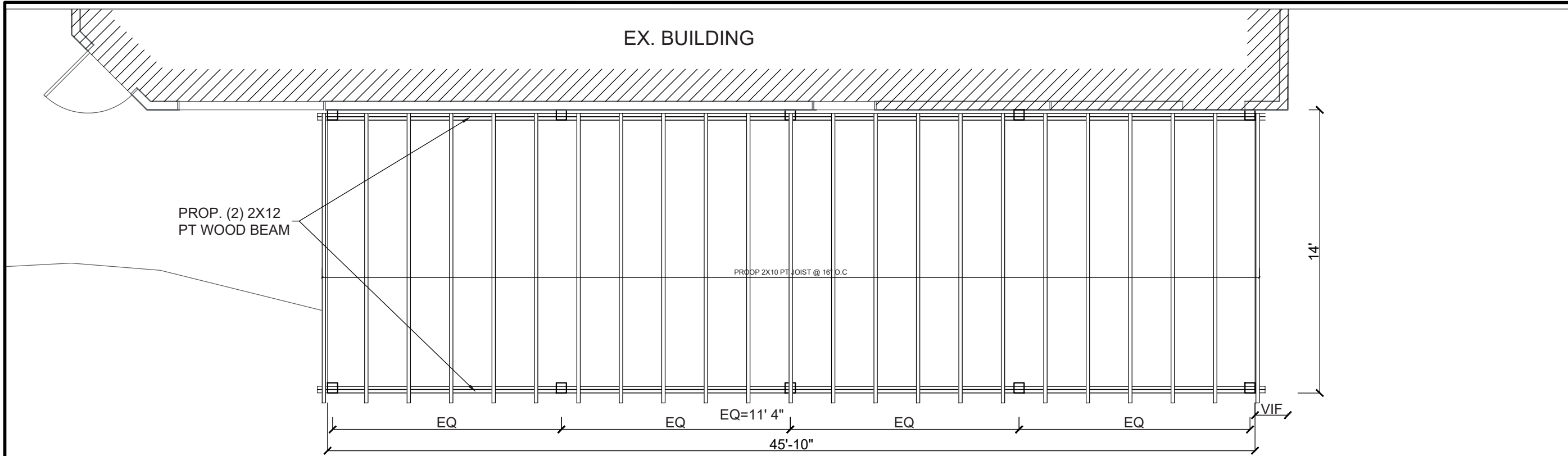

2
S001 PERGOLA ROOF FRAMING PLAN
SCALE 3/8" = 1'-0"

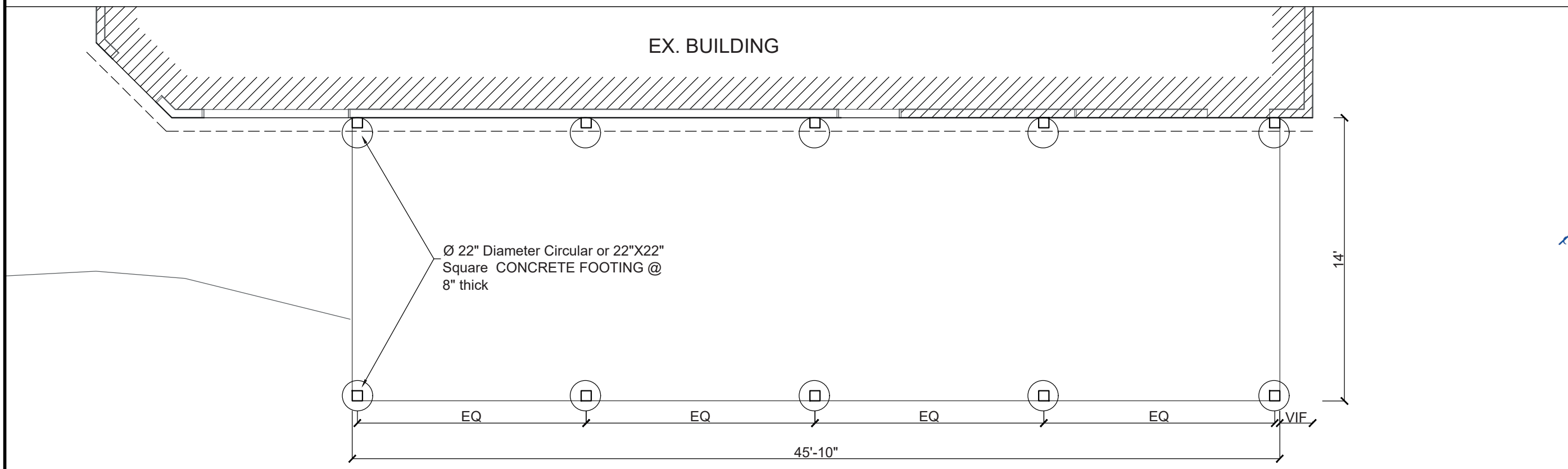

1
S001 FOOTING PLAN
SCALE 3/8" = 1'-0"

PERGOLA ADDITION
2415 SHIRLINGTON RD,
VA 22206

MTE S ENGINEERING SERVICES
11091 Molly Pitcher Circle
703 606 3386
MTEseng@outlook.com

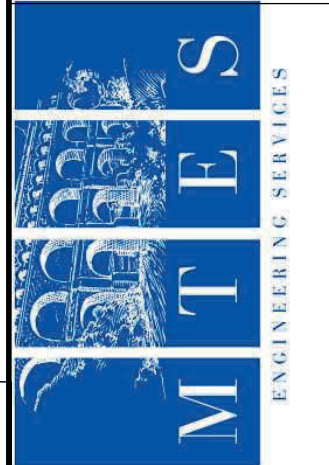

Anwar Maharmeh

No	Description	Date

Description
STRUCTURAL PLANS

S101

Project Number
Date 06-12-2023
Drawn By
Checked By

Scale

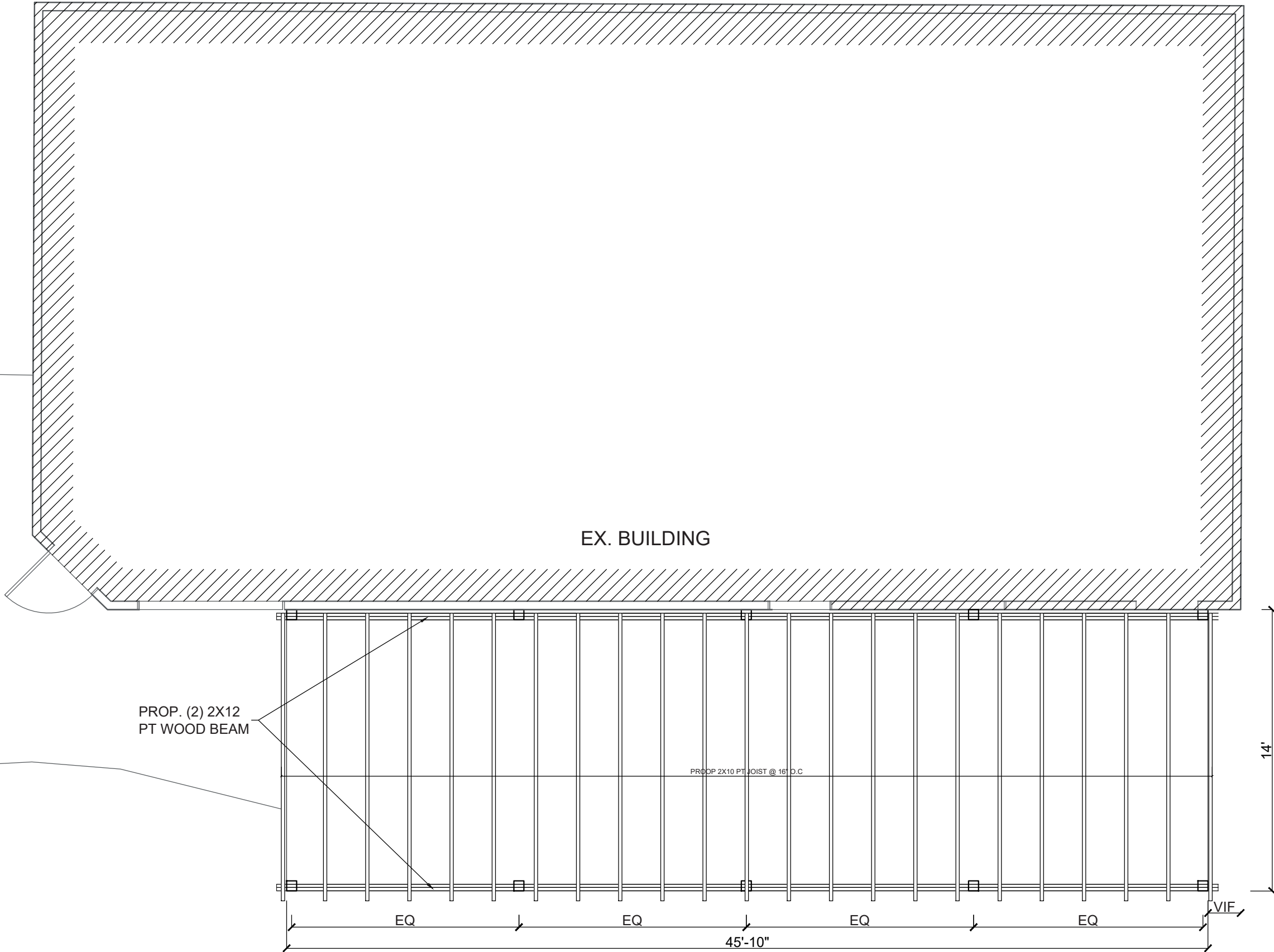

2
S001
PERGOLA ROOF FRAMING PLAN
 SCALE $\frac{3}{8}" = 1'-0"$

PERGOLA ADDITION
 2415 SHIRLINGTON RD,
 VA 22206

MTE ENGINEERING SERVICES
 11091 Molly Pitcher Circle
 703 606 3386
 MTEseng@outlook.com

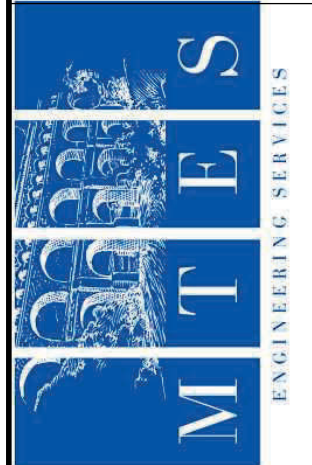

No	Description	Date

Description
EX. FRAMING PLAN

S102

Project Number
 Date 06-12-2023
 Drawn By
 Checked By

Scale

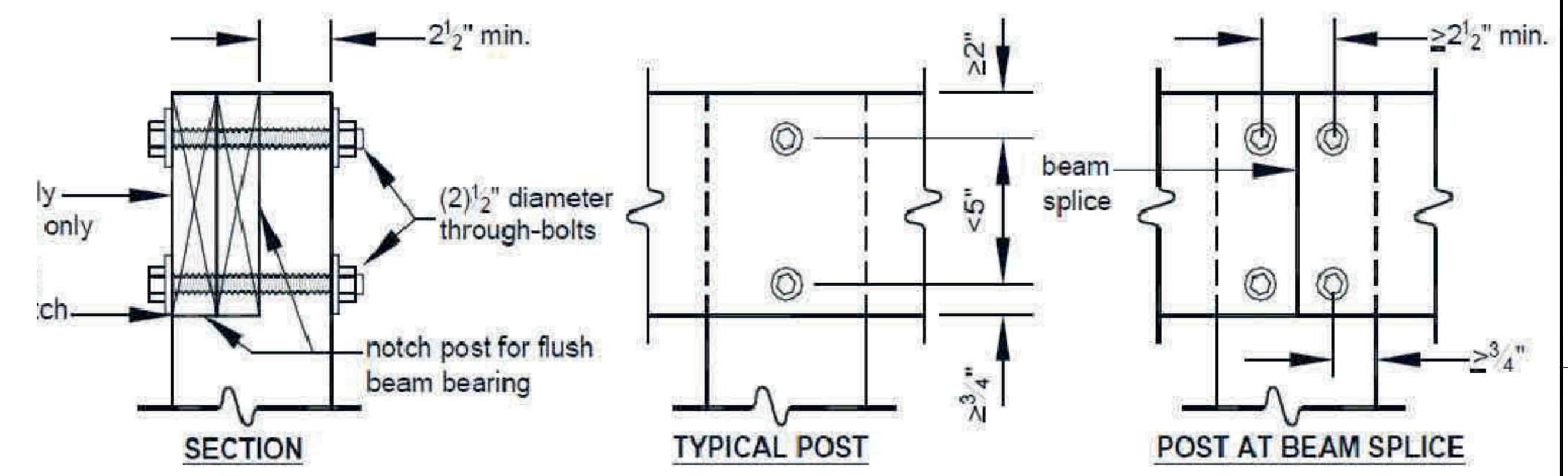
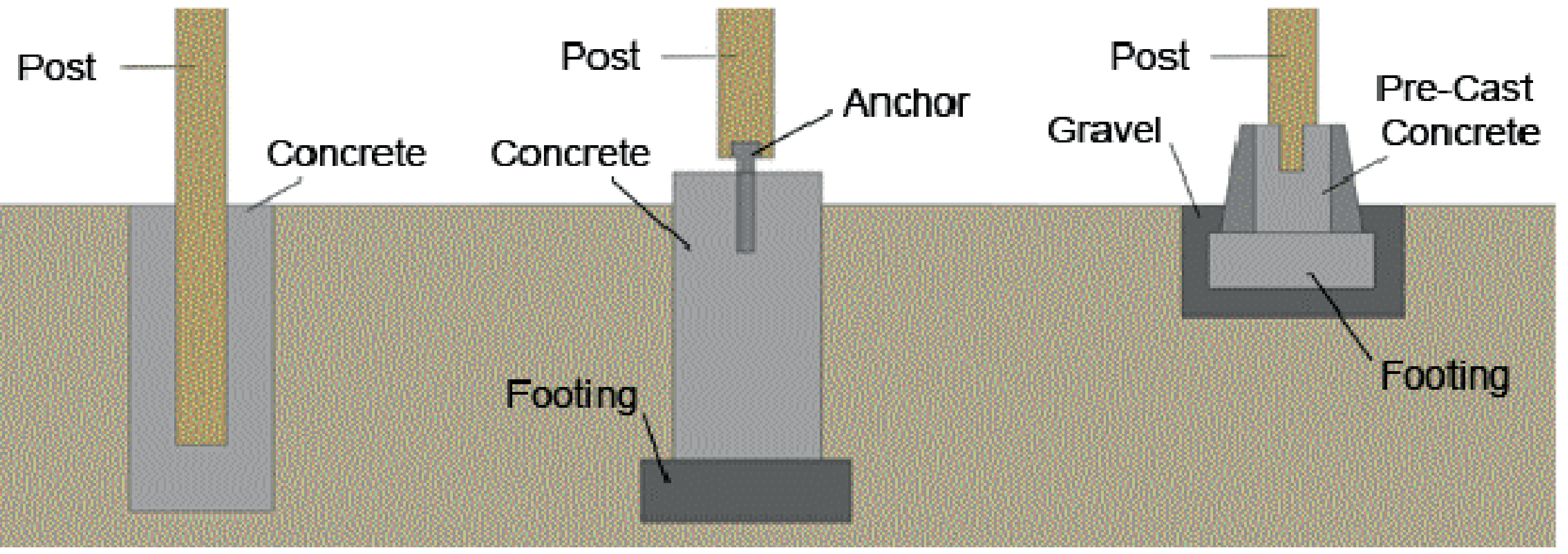
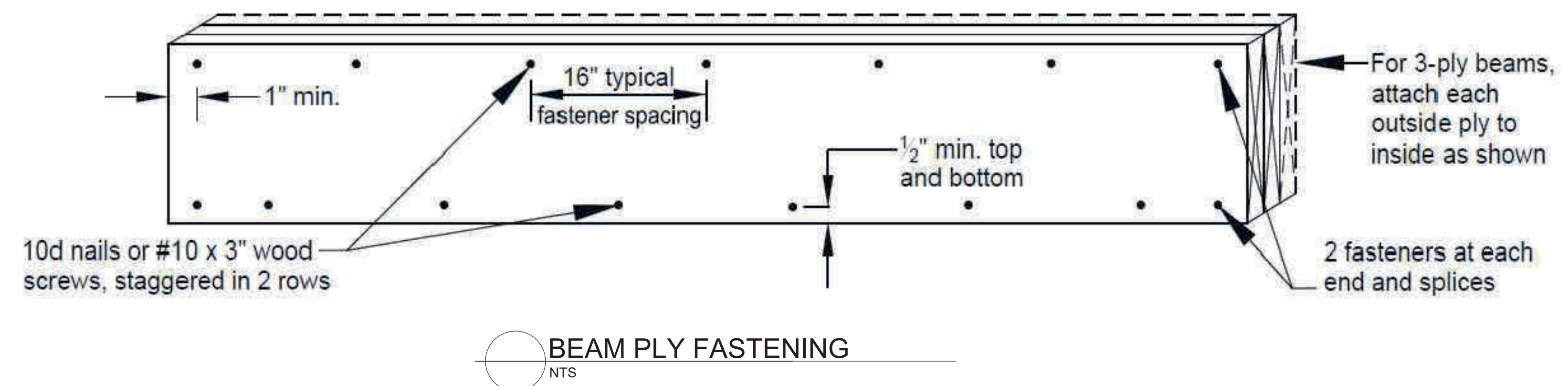
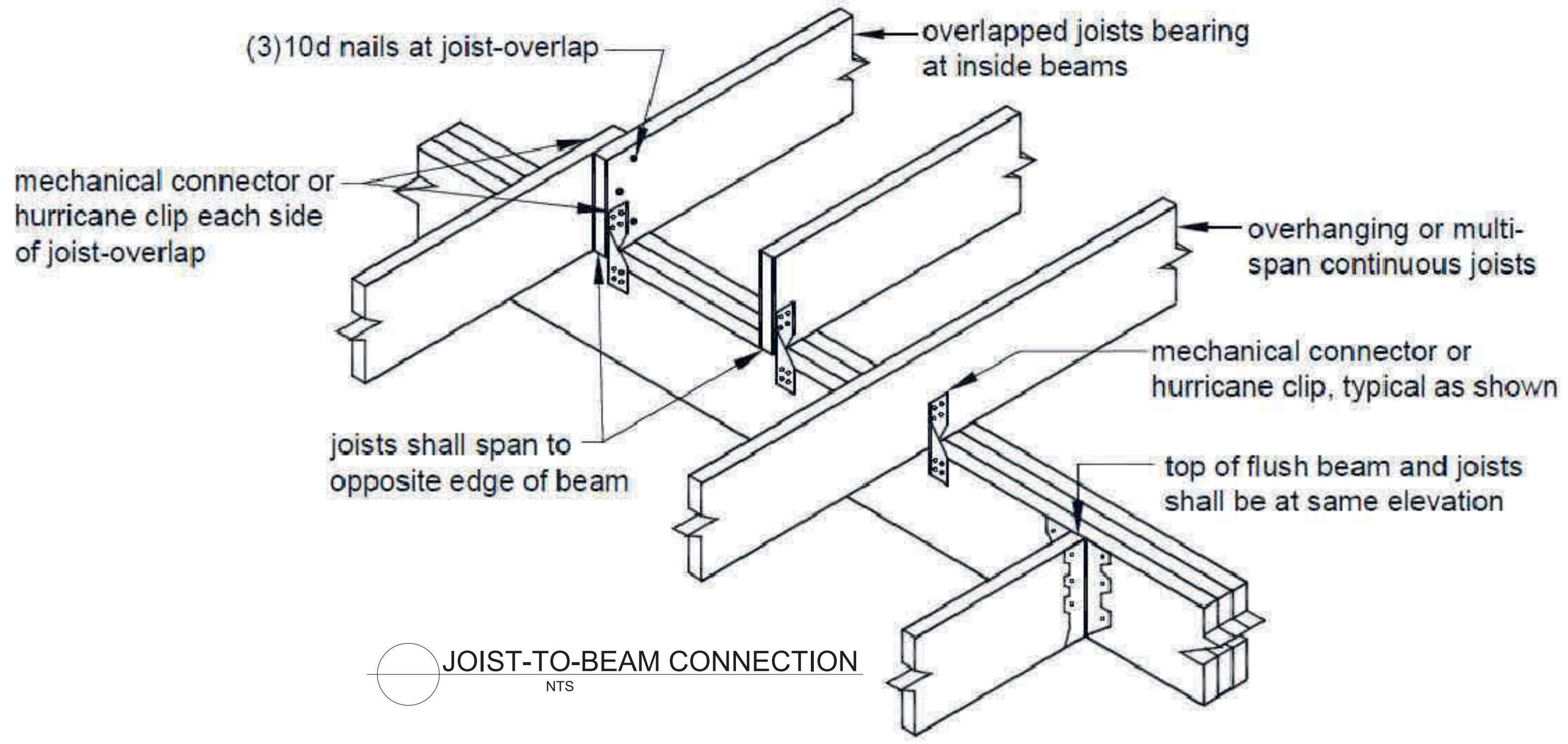
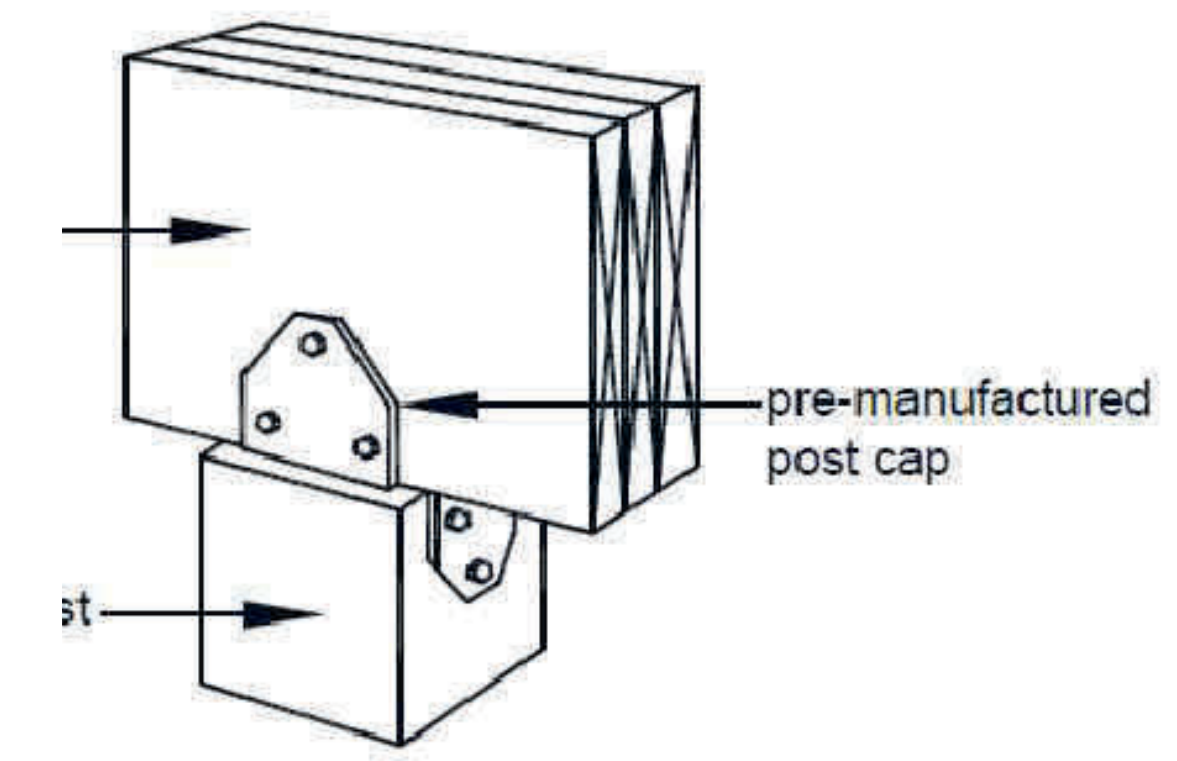

FIGURE 18: NOTCHED 6x6 POST-TO-BEAM CONNECTION



POST TO CAP CONNECTION
NTS

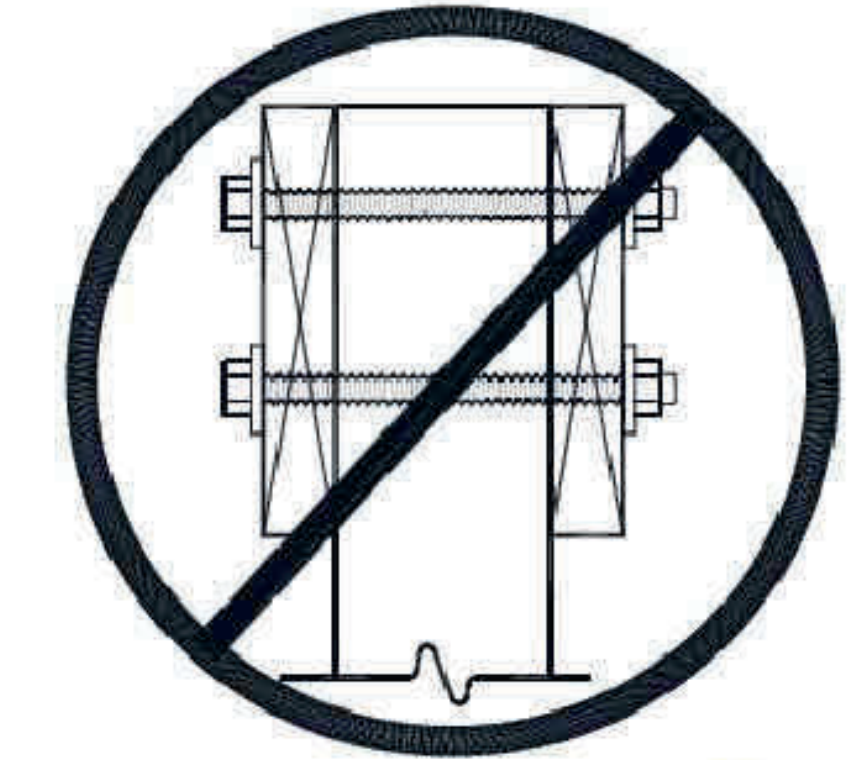

FIGURE 20: PROHIBITED CONNECTION

PERGOLA ADDITION
2415 SHIRLINGTON RD,
VA 22206

MTES ENGINEERING SERVICE
11091 Molly Pitcher Circle

703 606 3386

MTESeng@outlook.com

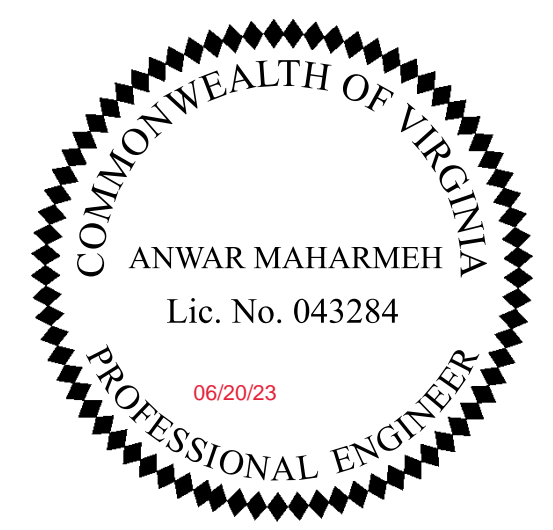
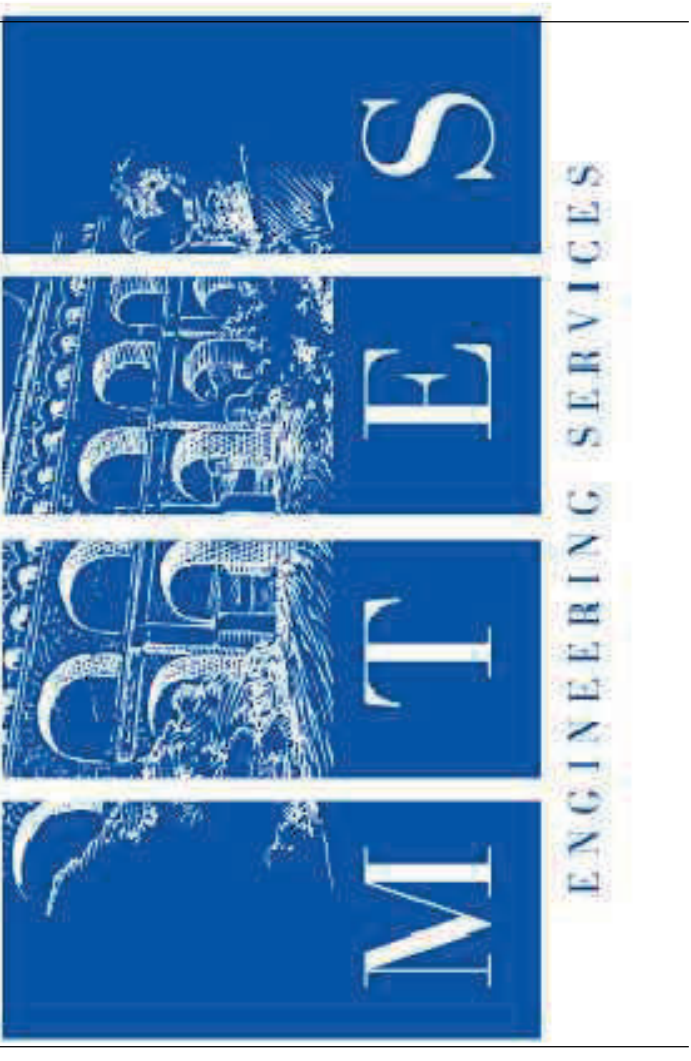

Anwar Maharmeh

No	Description	Date

Description

STRUCTURAL DETAILS

Project Number
Date 06-12-2023
Drawn By
Checked By

S103

Scale NTS