

# Historical Affairs and Landmark Review Board

Arlington County, Virginia



**HALRB Meeting April 17, 2024, CoA 24-10**

**1758 N. Rhodes St.:** Request to remove an existing skylight and replace with a roof hatch.

**COLONIAL VILLAGE II CONDOMINIUM**

1903 N. Key Boulevard  
Arlington, Virginia 22201  
(703) 525-5557 Office | (703) 525-5558 Fax

March 25, 2024

Department of Community Planning, Housing & Development  
Historical Affairs & Landmark Review Program  
2100 Clarendon Boulevard, Ste. 700  
Arlington, VA 22201 (703) 228-3549

RE: Roof Hatch Installation  
1758 N Rhodes Street

On behalf of the Association's Board of Directors, Management approved a structural request for the installation of a roof hatch at the above referenced location. Please find attached supporting documentation being submitted for a Certificate of Appropriateness.

Please contact the Management office with any questions.

Best regards,

*Chuck Vaughan*

Chuck Vaughan, CMCA®  
General Manager  
[CVaughan@legumnorman.com](mailto:CVaughan@legumnorman.com)

cc: Board of Directors

ADDRESS: 1758 RHODES ST.

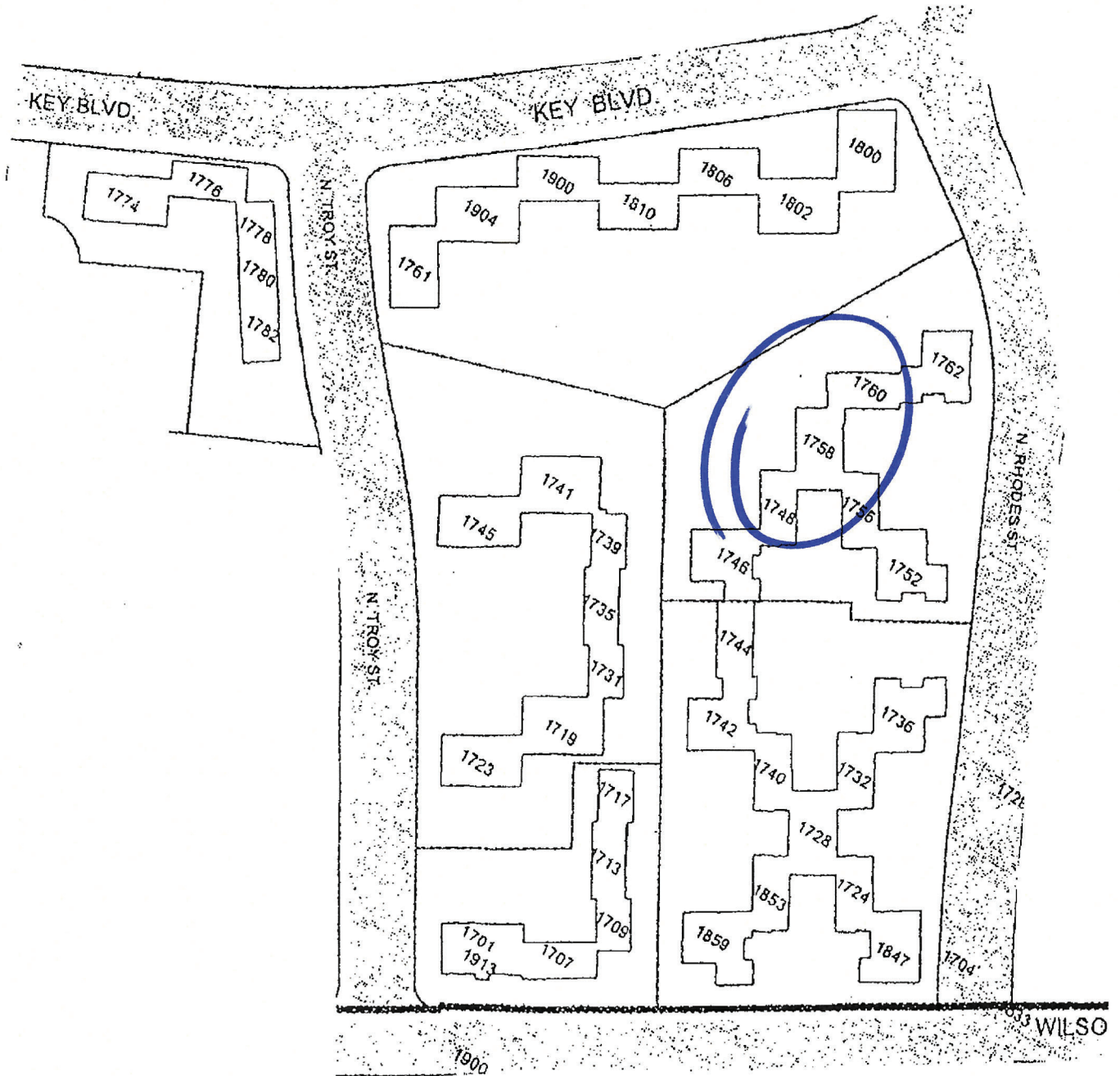

▲ NORTH

**COLONIAL VILLAGE II, A CONDOMINIUM  
ARLINGTON, VIRGINIA 22201**

\* 1758 RHODES ST North — ROOF PLAN

\* Roof Hatch Install — AT Existing Hall Skylight

— 40' —

VUSBC 2018

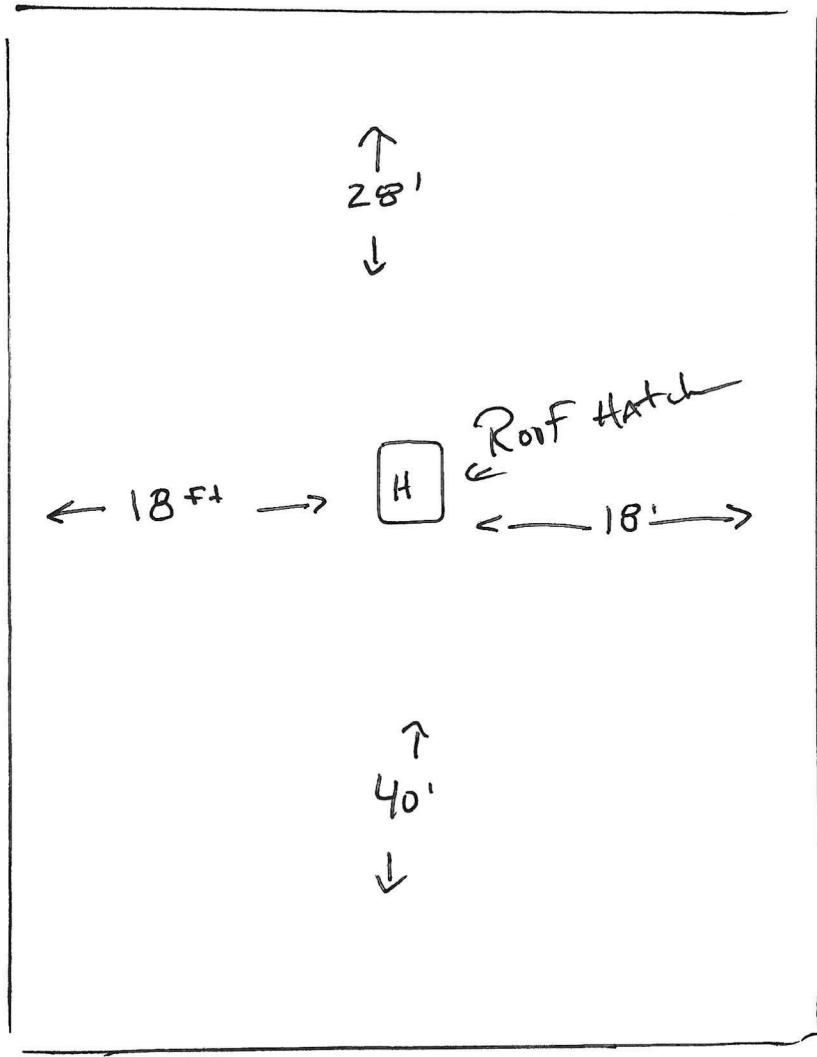

70'

# VUSBC 2018



12/22/2023

## S100

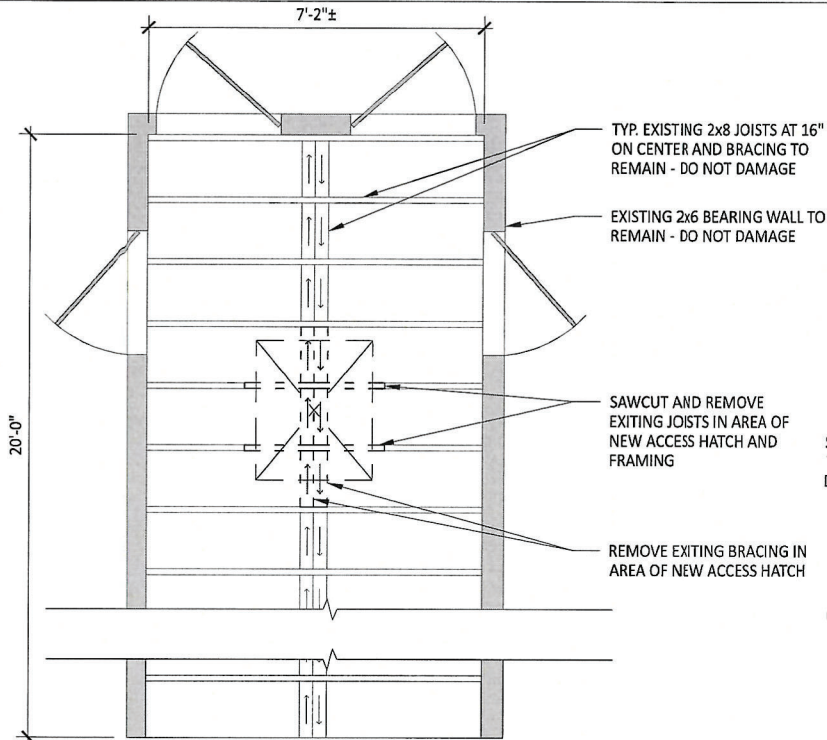

**1 DEMOLITION PLAN**

S100 SCALE: 3/8" = 1'-0"

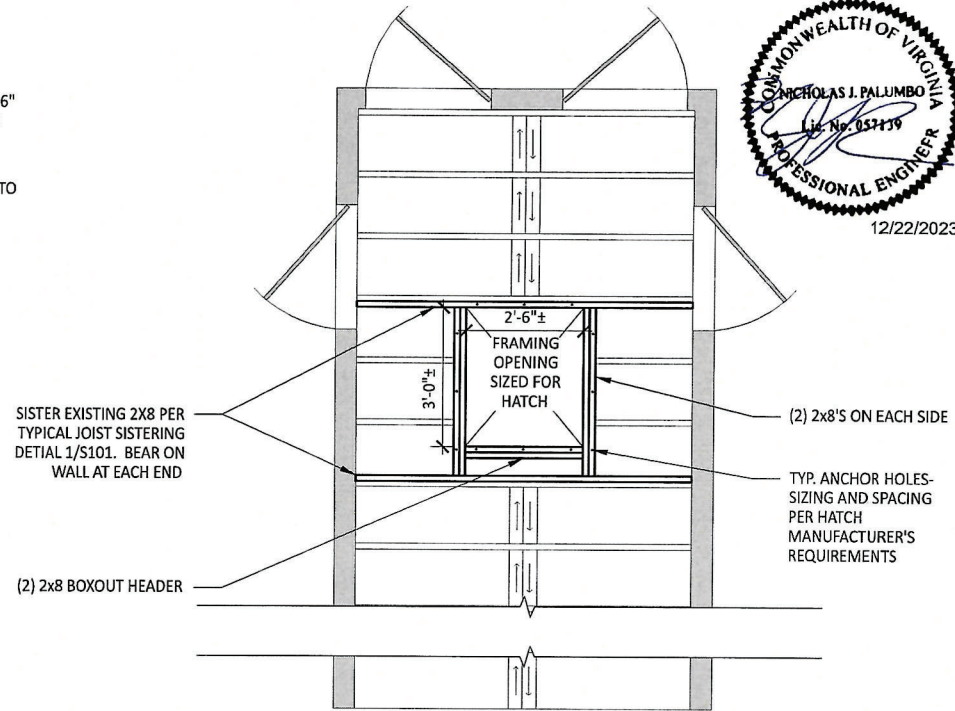

**2 FRAMING PLAN**

S100 SCALE: 3/8" = 1'-0"

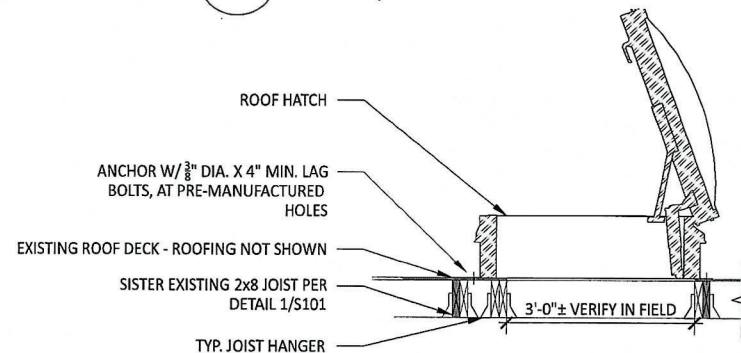

**3 HATCH FRAMING - SECTION VIEW**

S100 SCALE: 1/2" = 1'-0"

**NOTES:**

1. ROOF HATCH LOCATION: CENTER ROOF HATCH IN COORIDOR AND POSITION AS FAR AWAY FROM STAIRCASE AS POSSIBLE WITHOUT INTERFEREING WITH EXISTING LIGHTING, WIRING AND MECHANICAL EQUIPMENT.
2. ROOF HATCH DESIGN, AND WATERPROOFING AND FLASHING OF THE ROOF HATCH IS NOT IN THIS SCOPE.
3. FRAMING DESIGN HAS BEEN BASED ON BILCO GS-50. CONTRACTOR TO VERIFY DIMENSIONS IN FIELD AND CONTACT DESIGN ENGINEER IF HATCH SIZE OR WEIGHT IS NOT COMPATIBLE.

**FRAMING PLAN**  
 COLONIAL VILLAGE II  
 ROOF HATCH FRAMING PLAN  
 20230630



Building Envelope Consultants and Scientists, L.L.C.

DRAWN: AKMH

DESIGNED: NP

DATE: 12-14-2024

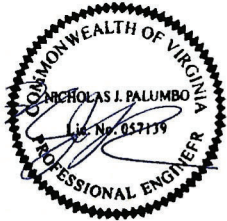

12/22/2023

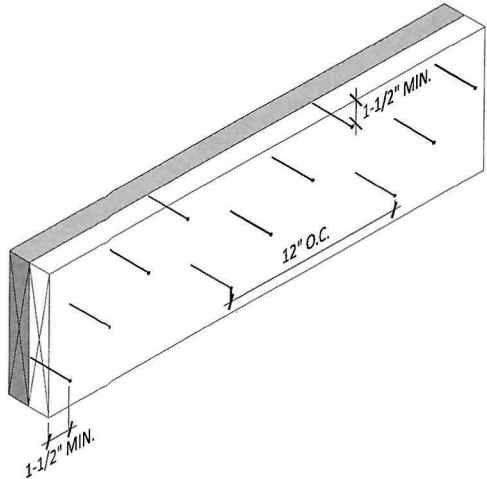

NOTES:

- 1. SISTER ONE COMPLETE SIDE OF JOIST FROM BEARING WALL TO BEARING WALL.
- 2. NAILS SHALL BE 10d COMMON NAILS - EVENLY SPACED AT 12" ON CENTER AS SHOWN.
- 3. MINIMUM EDGE DISTANCE SHALL BE 1-1/2".
- 4. CONTRACTOR SHALL FEILD VERIFY ALL DIMENSIONS.

**1** TYPICAL JOIST SISTERING  
 S101 SCALE: 1-1/2" = 1'-0"

S101

DETAILS  
 COLONIAL VILLAGE II  
 ROOF HATCH FRAMING PLAN  
 20230630

DRAWN: AKMH

DESIGNED: NP

DATE: 12-14-2024



Building Envelope Consultants and  
 Scientists, LLC.

**TYPICAL, EXISTING SKYLIGHTS AT COLONIAL VILLAGE I, II & III CONDOMINIUMS – 2024**



**VIEW OF PROPOSED SUBJECT - 1758 N RHODES ST**

**FROM PEDESTRIAN SIDEWALK ALONG N RHODES ST – HATCH SET BACK APPROX 20'**





**2005 N KEY BLVD (NON-LHD) WHERE SAME HATCH ALREADY INSTALLED**

**Outside View from Across the Street – Hatch is not Visible**



**2005 N KEY BLVD (NON-LHD) WHERE SAME HATCH ALREADY INSTALLED**

**Outside View**



**2005 N KEY BLVD (NON-LHD) WHERE HATCH ALREADY INSTALLED**

**Inside Access Now Capable w/ 8-ft Ladder**





# Mechanically Attached Installation Specification

TPO & PVC

## Part 1 – General

### 1.01 System Description

- A. Mechanically attached heat-welded thermoplastic sheet roof membrane system.
- B. EverGuard® PVC and EverGuard® TPO materials are not compatible with one another. DO NOT use EverGuard® PVC and EverGuard® TPO membranes, flashings, and flashing accessories together in the same roofing system.

### 1.02 Specification Designations

- A. See Plates.

### 1.03 Regulatory Requirements

- A. Conform to all applicable building and jurisdictional codes, including roof assembly wind uplift and fire resistance requirements and slope.
- B. Follow your local jurisdiction requirements for disposing of used and expired adhesives and sealants.

### 1.04 Delivery, Storage and Protection

- A. Deliver products to site in original containers with seals unbroken and labeled with manufacturers' name, product brand name and type.
- B. Store materials in weather protected environment, clear of ground and moisture, in accordance with GAF instructions.
- C. All materials stored outside shall be raised above ground or roof level on pallets, and covered with a tarpaulin or other waterproof material. Factory-installed plastic wrapping is not an adequate covering. Extreme heat conditions may require special storage requirements. Reference data sheets for product storage requirements.
- D. Follow GAF directions and requirements for protection of materials prior to and during installation.
- E. Do NOT use materials that are wet or damaged to the extent that they will no longer serve their intended purpose. All roof insulation that has been wet is considered damaged, even if later dried out. Remove all damaged materials from the jobsite.

### 1.05 Environmental Requirements & Restrictions

- A. Do not apply roofing materials during inclement or threatening weather.
- B. Do not expose materials vulnerable to water or sun damage in quantities greater than can be weatherproofed during the same day.
- C. High or gusting winds make the installation of materials difficult.
- D. Material installation during periods of high ambient temperatures, typically above 90°F, can result in poor installation quality due to condensation on the membrane

surface, and excessively fast adhesive drying rates.

- E. Material installation during periods of low ambient temperatures, typically below 30°F, can result in poor installation quality due to increased material stiffness and vulnerability to damage and excessively slow adhesive drying rates. To avoid these problems:
  - 1. Store accessory materials in a warming box
  - 2. Use as soon as possible
  - 3. Allow adhesives to properly cure
  - 4. Adjust welder settings to insure proper welds for applicable ambient conditions

### 1.06 Working Environment

- A. Provide a safe working environment, including, but not limited to, adequate fall protection, restriction of unauthorized access to the work area, and protection of the building and its occupants.
- B. Safe work practices should be followed, including, but not limited to, keeping tools in good operating order, providing adequate ventilation if adhesives are used, and daily housekeeping to remove debris and other hazards.

## Part 2 – Products

### 2.01 Membrane

- A. EverGuard® TPO (smooth reinforced) thermoplastic polyolefin membrane.
- B. EverGuard® TPO Fleece-Back thermoplastic polyolefin membrane
- C. EverGuard® PVC (smooth reinforced) thermoplastic membrane
- D. EverGuard® PVC Fleece-Back thermoplastic membrane

### 2.02 Flashing

- A. EverGuard® membrane flashings to be of same type, thickness and color as roofing membrane. EverGuard® Freedom™ TPO can be used with EverGuard® TPO membrane for flashing in the same thickness as the field membrane.
- B. EverGuard® TPO and PVC Fleece-Back membranes are optional flashing membranes for all EverGuard® TPO and PVC roofing systems, respectively. These membranes may be a solution when a contaminated substrate is encountered.

### 2.03 Flashing Accessories

- A. EverGuard® preformed flashing accessories to be of same type as roofing membrane.
  - 1. EverGuard® TPO and PVC laminated metal flashings to be a minimum of 25 mils TPO and 40 mils PVC of

# Mechanically Attached Installation Specification

## TPO & PVC

non-reinforced thermoplastic membrane of same type as roofing membrane, laminated to 24 ga. galvanized steel sheet metal.

2. Pre-formed Vent Boots with stainless steel clamping bands.
3. Pre-formed Universal Corners for TPO. Individual pre-formed inside outside corners for PVC.
4. Pre-formed Expansion Joint Covers for roof-roof and roof-wall expansion joints.
5. Membrane Flashing Strips for miscellaneous applications.
6. UN-55 Detailing Membranes for TPO flashing. UN-80 Detailing Membranes for PVC flashing. For miscellaneous penetrations in lieu of pre-formed accessories.
7. EverGuard® TPO Cover Strip for stripping in of flat metal edges.
8. EverGuard® Pre-formed Sealant Pans are available for irregularly-shaped penetrations and pitch pans.

### 2.04 Fasteners

- A. DRILL-TEC™ membrane fasteners and plates, insulation fasteners and plates, and flashing fasteners and termination bars. Refer to the Insulation Attachment Table and the appropriate Membrane Attachment Table at the end of this section for the correct type, length and diameter.

### 2.05 Adhesives and Sealants

- A. EverGuard® bonding adhesives, sealants and caulking.
1. EverGuard® TPO and PVC Bonding Adhesive (solvent-based).
  2. EverGuard® H2O Bonding Adhesive (low VOC).
  3. EverGuard® 2-Part Pourable Sealant for use in sealant pans.
  4. EverGuard® Caulking for use in sealing termination bars and penetration clamping bands.
  5. EverGuard® TPO Cut Edge Sealant. EverGuard® PVC Cut Edge Sealant.
  6. EverGuard® Water Block for use in sealing behind termination bars and at drain flanges as a water cut-off.
  7. EverGuard® TPO Primer.

### 2.06 Traffic Protection

- A. EverGuard® TPO and PVC walkway rolls.

### 2.07 Insulation

- A. EnergyGuard™ foam insulation of the following types. Minimum 1" thickness. Board size to be 4' x 8' panels for mechanical attachment, and 4' x 4' for adhered attachment and tapered systems.

1. EnergyGuard™ and EnergyGuard™ Ultra polyisocyanurate insulation with glass-based facer meeting or exceeding the requirements for ASTM C-1289 (min. 16 psi compressive strength).
2. EnergyGuard™ extruded polystyrene insulation meeting or exceeding the requirements for ASTM C-578, Type II nominal 1.5 pound density.
3. EnergyGuard™ expanded polystyrene insulation with plastic facer meeting or exceeding the requirements for ASTM C-578, Type II nominal 1.5 pound density.

### 2.08 Insulation – High Traffic Applications

- A. EnergyGuard™ foam insulation of the following types. Minimum 1" thickness. Board size to be 4' x 8' panels for mechanical attachment, and 4' x 4' for adhered attachment and tapered systems.
1. EnergyGuard™ and EnergyGuard™ Ultra polyisocyanurate insulation with glass-based facer meeting or exceeding the requirements for ASTM C-1289, (min. 25 psi compressive strength).
  2. EnergyGuard™ extruded polystyrene insulation meeting or exceeding the requirements for ASTM D-578, Type IV (min. 25 psi compressive strength).
  3. EnergyGuard™ expanded polystyrene insulation with plastic facer meeting or exceeding the requirements for ASTM D-578, Type IX (min. 25 psi compressive strength).

### 2.09 Recover Board

- A. EnergyGuard™ Perlite insulation, minimum 1/2", ASTM C-728
- B. High density wood fiber insulation, minimum 1/2", ASTM C-208, Class E
- C. EnergyGuard™ foam recover board of the following types. Board size to be 4' x 8' panels for mechanical attachment, and 4' x 4' for adhered attachment and tapered systems, except for fan-fold recover board, which comes in 2' x 4' sections with a 50' total length.
1. EnergyGuard™ and EnergyGuard™ Ultra 1/2" polyisocyanurate recover board insulation with glass-based facer meeting or exceeding the requirements for ASTM C-1289 (min. 16 psi compressive strength).
  2. EnergyGuard™ 3/8" extruded polystyrene fan-fold recover board with plastic facer meeting or exceeding the requirements for ASTM D-578, Type IV (min. 25 psi compressive strength).
  3. EnergyGuard™ 1/2" extruded polystyrene recover board meeting or exceeding the requirements for ASTM D-578, Type IV (min. 25 psi compressive strength).
4. EnergyGuard™ 1/2" expanded polystyrene recover board with

# Mechanically Attached Installation Specification

TPO & PVC

plastic facer meeting or exceeding the requirements for ASTM D-578, Type II (min. 15 psi compressive strength).

## 2.10 Base Sheets

- A. GAFGLAS® Stratavent® Eliminator™ Nailable Base Sheet
- B. GAFGLAS® #80 Ultima™ Base Sheet
- C. GAFGLAS® #75 Base Sheet

## 2.11 Protection Layer

- A. EverGuard® Polymat slipsheet, 3.0 oz/sq.yd.
- B. EverGuard® Polymat cushioning slipsheet, 6.0 oz/sq.yd.
- C. VersaShield™ products as protection layer in all sections (fully adhered, ballasted, etc.)

## 2.12 Other Accessories

- A. Subject to compliance with requirements, provide the following products not available from GAF:
  - 1. Wood Nailers: New wood nailers shall be #2 or better lumber. Do NOT use asphaltic or creosote-treated lumber.
  - 2. Roofing Nails: Galvanized or non-ferrous type and size as required to suit application.
  - 3. Temporary Sealant: Polyurethane foam sealant or similar as required to provide temporary watertight sealing of roofing.
  - 4. Air/Vapor Barrier: Polyethylene sheeting, min. 6 mil. for TPO only.
  - 5. Fire Barrier: Silicone-treated fiberglass-faced gypsum panels, min. 1/4" thick (gypsum roof from Georgia-Pacific).

## Part 3 – Execution

### 3.01 Site Conditions

- A. Obtain verification that the building structure can accommodate the added weight of the new roofing system.
- B. Confirm the adequacy of the new roofing system to provide positive slope to drain. Eliminate ponding areas by the addition of drainage locations or by providing additional pitch to the roof surface.
- C. All defects in the roof deck or substrate shall be corrected by the responsible parties before new roofing work commences. Verify that the deck surface is dry, sound, clean and smooth, free of depressions, waves, or projections.
- D. Protect building surfaces against damage and contamination from roofing work.
- E. Where work must continue over completed roof areas, protect the finished roofing system from damage.

- F. Deck preparation is the sole responsibility of the building owner or roofing contractor. All defects in the roof deck or substrate shall be corrected before roofing work commences.

### 3.02 Preparation of Roofing Area – New and Tear-off Applications

- A. Remove all existing roofing materials to the roof decking, including flashings, metal edgings, drain leads, pipe boots, and pitch pockets, and clean substrate surfaces of all asphalt and adhesive contaminants.
- B. Confirm quality and condition of roof decking by visual inspection and by fastener pull-out testing.
- C. Secure all loose decking. Remove and replace all deteriorated decking.
- D. Remove abandoned equipment and equipment supports.
- E. Confirm that height of equipment supports will allow the installation of full-height flashings.

### 3.03 Preparation of Roofing Area – Recover Applications

- A. Remove all stone ballast, loose gravel, and debris from the roof surface.
- B. Remove blisters and ridges from the roof membrane.
- C. When recovering over an existing single ply roof, that roof must be first cut into 10'x10' areas maximum first, before the application of new separator sheet and/or membrane.
- D. Remove all existing flashings, including metal edgings, drain leads, pipe boots, and pitch pockets, and clean substrate surfaces of all asphalt and adhesive contaminants. If the wall/curb flashings are in good condition and tightly adhered to the substrate, new TPO flashing materials may be installed over these to a height of 24"; new PVC flashing materials may be installed over a separator layer of polymat or insulation board.
- E. It is strongly recommended that the building owner have a moisture survey performed to ascertain the condition and suitability of the existing roofing materials to receive a recover system. A survey is required if perlite or wood fiber insulation is used in a recover system. GAF will not be responsible for damage to the roofing system if it results from moisture in the existing roofing system. Remove and replace all existing roofing materials that contain moisture.
- F. Confirm quality and condition of roof decking by visual inspection if possible, and by fastener pull-out testing. Remove and replace all deteriorated decking.
- G. Remove abandoned equipment and equipment supports.
- H. Raise equipment supports to allow the installation of full-height flashings.

# Mechanically Attached Installation Specification

TPO & PVC

- I. Recover installation over coal tar pitch roofs require that the existing loose gravel be broomed (do not spud); if high spots remain, use a thicker insulation board to provide a smooth substrate for the EverGuard® membrane. Recover with EverGuard® TPO membranes over coal tar pitch roofs require the installation of a minimum 1/2" recover board prior to the installation of the membrane. Do not use EPS/XEPS over coal tar pitch roofs. A minimum 1.5" recover board is required for PVC applications.

## 3.04 Wood Nailer Installation

### A. Acceptable Material

1. Solid Blocking:  
Wood, #2 Grade or better, nominal 5/4" x 4" minimum; stagger multiple layers.
2. Shim Material:  
Plywood, 1/2" x width to match solid blocking.

### B. Existing Nailers

Anchor to resist 250 lb. per ft. load applied in any direction.

1. DRILL-TEC™ HD screws 18" on center attachment to structural wood, steel decks. Min. 1" thread embedment.
2. DRILL-TEC™ spikes 18" on center attachment to concrete decks. Min. 1" shank penetration.
3. Wood nailers attached to gypsum, concrete, cellular concrete and cementitious wood fiber shall be fastened 12" oc, through the nailer into the substrate with substrate-approved DRILL-TEC™ fasteners.
4. Three anchors per length of wood nailer minimum.

### C. New Nailers

Anchor to resist 250 lb. per ft. load applied in any direction.

1. DRILL-TEC™ HD screws 18" on center attachment to structural wood, steel decks. Min. 1" thread embedment.
2. DRILL-TEC™ spikes 18" on center attachment to concrete decks. Min. 1" shank penetration.
3. Wood nailers attached to gypsum, concrete, cellular concrete and cementitious wood fiber shall be fastened 12" oc, through the nailer into the substrate with substrate-approved DRILL-TEC™ fasteners.
4. Three anchors per length of wood nailer minimum.

### D. Shim Material

Secure simultaneously with overlying solid wood nailer.

1. Shim material must be continuous. Do NOT use spaced shims.

## 3.05 Gypsum Board Installation

### A. General

1. Gypsum fire barrier board shall typically be installed when required by design professional or code authority to address code or approval requirements.

### B. Placement

1. Butt gypsum boards together with a 1/4" maximum space between adjoining boards. Fit gypsum boards around penetrations and perimeter with a 1/4" maximum space between board and penetration.
2. Install gypsum boards in pieces a minimum of 2' x 2' in size.
3. Gypsum boards installed over steel decking shall have boards placed perpendicular to deck flutes with edges over flute surface for bearing support.
4. Do NOT use gypsum boards that are wet, warped or buckled; they must be discarded. Insulation boards that are broken, cracked, or crushed shall not be installed unless the damaged area is first removed and discarded.
5. Remove and replace gypsum boards that become wet or damaged after installation.
6. Install no more gypsum board than can be properly covered by the end of each day with roofing membrane.

### C. Securement

#### 1. Mechanical Attachment

- a. Use appropriate type and length of DRILL-TEC™ fastener for structural deck type. See Insulation Attachment Table.
- b. Install required number of fasteners per board size, and type of roofing system installed.
- c. Pre-drilling is required for concrete decks, and may be required for gypsum concrete and cementitious wood fiber decks.
- d. Install fasteners such that the fastener plate is pulled slightly below the insulation board surface.

#### 2. Hot Asphalt

- a. Use ASTM D-312, Type III or Type IV asphalt.
- b. Apply asphalt at the rate of 25 lbs. per 100 sq. ft. over the entire surface to which the board is to be adhered.
- c. Asphalt application rates of up to 60 lbs. per 100 sq. ft. may be required if the substrate surface is rough or porous, such as an existing flood coat and gravel surfacing.
- d. Apply asphalt at its EVT temperature to obtain a proper bond, typically within the range of 425°F-475°F.
- e. Walk in the boards after installation to ensure a proper bond.
- f. Maximum board size: 4' x 4'.
- g. Hot asphalt application requires priming of concrete and gypsum decks and existing asphaltic roofing systems.



# Mechanically Attached Installation Specification

TPO & PVC

## 3. Foam Adhesive

- a. Depending on foam adhesive type, apply adhesive in full 1/4" - 1/2" thick coverage or in 3/4"-1" continuous beads according to the manufacturer's instructions.
- b. Adhesive beads shall be evenly spaced at the rate required for the board size and type of roofing system being installed.
- c. Apply the proper grade adhesive based on current air and surface temperatures.
- d. Walk in the boards after installation to ensure a proper bond.
- e. Maximum board size: 4' x 4'.

## 3.06 Air/Vapor Retarder Installation

### A. General

1. Air/vapor retarder components shall typically be installed when required by design professional to address internal building air pressure or humidity conditions.
2. All air porous decks with openings in the walls or area directly below the roof deck that exceeds 10% of the total wall area are projects for which design professionals should recommend air retarders.
3. Designers should recommend air retarders when the internal pressurization of the building is in excess of 5 lbs. per sq. ft.
4. Designers should recommend air retarders if the building height exceeds 50 ft.
5. Buildings with large openings & overhangs shall be evaluated for air retarders or the installation of half sheets of roof membrane.
6. The installation of an air retarder shall be required for EverGuard® 20-year guarantees as follows:
  - a. All single layer installations of roof insulations or roof panels
  - b. Installations with openings in the wall that exceed 25% of the total wall area
  - c. Installations of 10' wide or greater membranes with side lap mechanical attachment that exceeds 6" o.c. (For 10' wide sheets, the requirements for an air barrier is dependent upon building height and fastener density. Contact your Regional Contractor Services Manager for air barrier requirements.)

### B. Application

1. Install the air/vapor retarder components loose-

applied to the deck or fire barrier board so that wrinkles and buckles are not formed.

2. Overlap air/vapor retarders components per applicable installation recommendations of the supplier.
3. Seal perimeter and penetrations areas with foam sealant.
4. Seal all perimeter nailers with fully adhered roof membrane placed over the nailer and covering the exterior face of the nailer by 1".

## 3.07 Protection Layer Installation – Polyester

### A. General

1. Install polymat protection layer between the roofing membrane and the substrate in accordance with the Design Table.

### B. Application

1. Install polymat protection layer loose-applied over substrate surface so that wrinkles and buckles are not formed.
2. Overlap polymat protection layer a minimum of 6" for side and end laps.

## 3.08 Protection Layer Installation – Fiberglass

### A. General

1. VersaShield™ protection layer shall typically be installed when required by design professional or code authority to address code or approval requirements, or as a separator layer in accordance with the Design Table.

### B. Application

1. Install fiberglass sheet protection layer loose-applied over substrate surface so that wrinkles and buckles are not formed.
2. Overlap fiberglass sheet protection layer a minimum of 6" for side and end laps.

## 3.09 Base Sheet Installation

### A. General

1. Fiberglass base sheet shall typically be installed over all nailable substrates other than gravel-surfaced built-up roofing whenever insulation, recover board, or fire barrier board is installed in hot asphalt or adhesive.
2. Nailable base sheet shall be applied over substrates that are not suitable for asphalt adhesion and requires installation of insulation in hot asphalt or adhesive.
3. Install base sheet so that wrinkles and buckles are not formed.
4. Overlap base sheet a minimum of 2" for side laps and 6" for end laps.

# Mechanically Attached Installation Specification

TPO & PVC

## B. Mechanical Securement-Nailable Base Sheet

1. Secure venting nailable base sheet through existing substrate to the deck. Use appropriate type and length of approved fastener for structural deck type and

Fig. 1

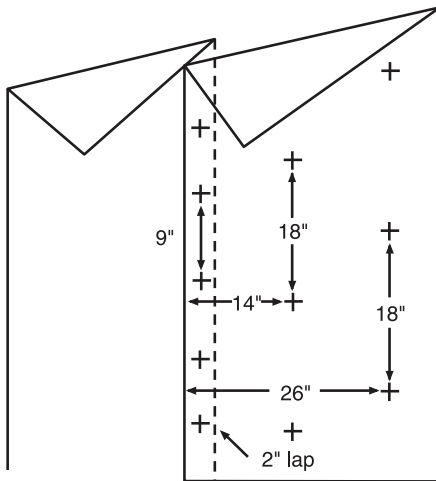

install required number of fasteners in accordance with Figure 1.

2. Pre-drilling is required for concrete decks, and may be required for gypsum concrete and cementitious wood fiber decks.
3. Install fasteners such that the fastener plate is pulled flush with the venting base sheet surface and lies flat on the deck.

## C. Base Sheet Installation

1. StormSafe™ is a non-breathable 48" wide underlayment which can be used over wood and light weight decks in conjunction with Freedom™ systems.
2. Install StormSafe™ underlayment so that wrinkles and buckles are not formed
3. Overlap base sheet a min of 2" for side laps and 6" for end laps
4. StormSafe™ underlayment should be attached at 9" o.c. along the 2" side laps with three rows of fasteners in the field located at 10", 24" and 38" with 18" o.c. fastening pattern. Use deck appropriate fasteners for attachment.

## 3.10 Recover Board/Insulation Installation

### A. General

1. Install insulation board and recover board as required in accordance with the Design Table.
2. The use of extruded and expanded polystyrene

insulations is limited to a maximum roof membrane temperature of 165°F. Use under colored membranes requires special approval from Contractor Services.

3. The use of extruded or expanded polystyrene insulation is limited in PVC roofing systems to under a fleece back membrane, where protected by a 3 or 6 oz. poly-mat slip sheet, or where an overlay board is used.

### B. Placement

1. Butt insulation boards together with a 1/4" maximum space between adjoining boards. Fit insulation boards around penetrations and perimeter with a 1/4" maximum space between board and penetration.
2. Install insulation boards in pieces a minimum of 2' x 2' in size. Every piece shall be properly secured to the substrate.
3. Insulation boards installed in multiple layers shall have the joints between boards staggered a minimum of 6" between layers.
4. Insulation boards installed over steel decking shall have boards placed perpendicular to deck flutes with edges over flute surface for bearing support.
5. Install tapered insulation to provide a sump area a minimum of 36" x 36" where applicable.
6. Do NOT install insulation boards that are wet, warped or buckled; they must be discarded. Insulation boards that are broken, cracked, or crushed shall not be installed unless the damaged area is first removed and discarded.
7. Remove and replace insulation boards that become wet or damaged after installation.
8. Install no more insulation than can be properly covered by the end of each day with roofing membrane.

### C. Securement

#### 1. Mechanical Attachment

- a. Use appropriate type and length of DRILL-TEC™ fastener for structural deck type. See Insulation Attachment Table.
- b. Install required number of fasteners per insulation type, board size, and type of roofing system installed.
- c. Pre-drilling is required for concrete decks, and may be required for gypsum concrete and cementitious wood fiber decks.
- d. Install fasteners such that the fastener plate is pulled slightly below the insulation board surface.
- e. Use fastener of correct length as required by the Insulation Attachment Table. The use of any fastener greater than 8" in length must be preapproved by GAF Contractor Services. May require a cover board.

#### 2. Hot Asphalt

# Mechanically Attached Installation Specification

## TPO & PVC

- a. Use ASTM D-312, Type III or Type IV asphalt.
  - b. Apply asphalt at the rate of 25 lbs. per 100 sq. ft. over the entire surface to which the insulation is to be adhered.
  - c. Asphalt application rates of up to 60 lbs. per 100 sq. ft. may be required if the substrate surface is rough or porous, such as an existing flood coat and gravel surfacing. When applying asphalt in this manner, the existing substrate must be free of dirt, dust and any loose materials. Depending on the existing roof, this may require vacuuming, power brooming or power washing.
  - d. Apply asphalt at its EVT temperature to obtain a proper bond, typically within the range of 425-475°F.
  - e. Walk in the insulation boards after installation to ensure a proper bond.
  - f. Maximum board size: 4' x 4'.
  - g. Hot asphalt application requires priming of concrete and gypsum decks and existing asphaltic roofing systems.
3. Foam Adhesive
- a. Depending on foam adhesive type, apply adhesive in full 1/4" - 1/2" thick coverage or in 3/4"-1" continuous beads according to the manufacturer's instructions.
  - b. Adhesive beads shall be evenly spaced at the rate required for the insulation board size and type of roofing system being installed.
  - c. Apply the proper grade adhesive based on current air and surface temperatures.
  - d. Walk in the insulation boards after installation to ensure a proper bond.
  - e. Maximum board size: 4' x 4'.

### 3.11 Membrane Installation

#### A. Placement

1. Place roof membrane so that wrinkles and buckles are not formed. Remove any wrinkles or buckles removed from the sheet prior to permanent securement. Roof membrane shall be mechanically fastened after it is rolled out, followed by welding to adjacent sheets.
2. Full-width rolls shall be installed in the field of the roof.
3. Half-width rolls shall be installed in the perimeter region of the roof. Width of the roof perimeter region shall be determined in accordance with the Perimeter Half Sheet Table.
4. Overlap roof membrane a minimum of 6" for side laps of mechanically attached systems, and a minimum of 3" for end laps. Membranes are provided with lap lines

along the side laps, the inside line is for mechanically attached system overlaps (6" for TPO and 5" for PVC) and the other line is for adhered and ballasted systems overlap.

5. Install membrane so that the laps run across the roof slope lapped toward drainage points. On metal decking, install sheets perpendicular to deck direction so that fasteners will penetrate the top flanges and not the flutes; however, there will be limited areas of the roof (i.e. perimeter areas) where this is not practical.
6. All exposed sheet corners shall be rounded a minimum of 1".
7. Overlap roof membrane a minimum of 3" for end laps of EverGuard® PVC and TPO membranes. End laps for EverGuard® fleece-back membranes are made by butting adjacent sheets and heat welding an 8" wide EverGuard® PVC or EverGuard® TPO reinforced membrane flashing strip over the joints.

#### B. Securement

1. Roof membrane shall be mechanically fastened in the side lap area to the roof deck with fasteners and plates of a type and spacing appropriate to the deck type and as required by the Membrane Attachment Table.
2. The metal plates must be placed within 1/4" - 3/4" of the membrane edge. Plates must not be placed closer than 1/4" to the membrane edge.
3. Fasteners must be installed to achieve the proper embedment depth. Install fasteners vertical to the deck, without lean or tilt.
4. In the corner areas, additional fasteners will also be installed through the perimeter half-width membrane rolls to form a grid pattern, with an 8" wide reinforced membrane flashing strip heat-welded over the additional fasteners. "Corners" include both outside and inside corners that measure 75°-105°. Perimeter cap sheets may overlap one another in the corner areas. Alternatively, the half sheet may be laid out in a "picture frame" manner, burying the fasteners under the half sheets.
5. Mechanically attach membrane with screws and plates to the roof deck at locations of deck angle changes in excess of 5° (2" in 12").
6. Membrane may be heat welded to coated metal flanges. Membrane must be secured to the roof deck within 6" of the base of walls and curbs, at the perimeter, and all penetrations with DRILL-TEC™ Fasteners of a type and spacing in accordance with in-lap attachment requirements, with a 12" on center maximum spacing. Alternatively, membrane may be extended vertically 3" up walls and curbs and secured to the wall/curb substrate within 2" of the plane of the roof with

# Mechanically Attached Installation Specification

TPO & PVC

DRILL-TEC™ Fasteners and inverted Termination Bar of type and spacing in accordance with in-lap attachment requirements, with a 12" on center maximum spacing. This alternative detail is required to be used for pressurized buildings.

7. Install fasteners so that the plate is drawn down tightly to the membrane surface. Properly installed fasteners will not allow the plate/termination bar to move (underdriving), but will not cause wrinkling of the membrane (overdriving).

## C. Field Seaming

1. Fabricate field seams using a current-generation automatic hot air welding machine and a 10,000 watt voltage-controlled generator minimum. In addition, fabricate detail seams with automated hot air welders where possible. Outdated welding equipment and inadequate/fluctuating electrical power are the most common causes of poor seam welds.
2. Equipment Settings- The correct speed and temperature settings for automatic welders are determined by preparing test welds at various settings. The welds are tested by application of pressure causing the seam to peel apart. A satisfactory weld will fail by exposing the scrim reinforcement called a "film tearing bond." A deficient weld fails by separating between the two layers of the membrane.
3. Adjustments to Equipment Settings- Many factors will affect the settings: thicker membranes, lower air temperatures, and overcast skies will generally require a slower speed than would be required with thinner membranes, higher air temperatures, and sunny skies. The slower speed provides additional heat energy to compensate for heat-draining conditions. The test weld procedure should be conducted at the beginning of every work period (i.e., morning and afternoon) and following a significant change in weather (i.e., air temperature, wind speed, cloud cover.)
4. Membrane laps shall be heat-welded together. All welds shall be continuous, without voids or partial welds. Welds shall be free of burns and scorch marks.
5. Weld width shall be a minimum 1-1/2" in width for automatic machine welding. Weld width shall be a minimum 2" in width for hand welding.
6. All cut edges of TPO and PVC reinforced membranes must be sealed with EverGuard® TPO or PVC Cut Edge Sealant.

## D. Substrate Surface Preparation

1. Prepare substrate surfaces thoroughly prior to application of new roofing materials. This is particularly important for recover and reroofing applications.

2. Preparation includes, but is not limited to, removal of existing flashings, replacement of wet/damaged existing roofing materials, removal of loose aggregate, removal of abandoned equipment, supports and penetrations, replacement of damaged decking, etc.
3. Providing a smooth, even, sound, clean and dry substrate minimizes the likelihood that underlying deficiencies will cause premature deterioration or even failure of the new roofing system.

## E. Membrane Surface Preparation

1. Membrane must be clean of dirt and contaminants, and free from dew, rain, and other sources of moisture. Factory-fresh membrane typically will not require cleaning prior to automatic welding, provided that welding is performed immediately after placement and securing of the membrane.
2. Membrane that has been exposed for over 12 hours or has become contaminated will require additional cleaning methods.
3. Light Contamination - Membrane that has been exposed overnight up to a few days to air-borne debris, foot traffic, or dew or light precipitation can usually be cleaned with a white cloth moistened with EverGuard® TPO use or acetone for PVC. Be sure to wait for solvent to flash off prior to welding.
4. Dirt-Based Contamination - Membrane that is dirt-encrusted will require the use of a low-residue cleaner such as Formula 409 and a mildly abrasive scrubbing pad to remove the dirt. This must be followed by cleaning with a white cloth moistened with EverGuard® TPO Cleaner or acetone for PVC. Be sure to wait for solvent to flash off prior to welding.
5. Exposure-Based Contamination - Membrane that is weathered/oxidized will require the use of EverGuard® TPO Cleaner or acetone for PVC and a mildly abrasive scrubbing pad to remove the weathered/oxidized top surface layer. This must be followed by cleaning with a white cloth moistened with EverGuard® TPO Cleaner or acetone for PVC. Unexposed membrane left in inventory for a year or more may need to be cleaned as instructed above. Be sure to wait for solvent to flash off prior to welding.
6. Chemical-Based Contamination - Membrane that is contaminated with bonding adhesive, asphalt, flashing cement, grease and oil, and most other contaminants usually cannot be cleaned sufficiently to allow an adequate heat weld to the membrane surface. The membrane should be removed and replaced in these situations.

## 3.12 Flashing Installation

# Mechanically Attached Installation Specification

TPO & PVC

## A. General

1. Flash all perimeter, curb, and penetration conditions with coated metal, membrane flashing, and flashing accessories as appropriate to the site condition.
2. All coated metal and membrane flashing corners shall be reinforced with pre-formed corners or unreinforced membrane.
3. Heat weld all flashing membranes, accessories, and coated metal together to achieve a minimum 2" wide (hand welder) weld. A minimum 1.5" will be acceptable when using robotic welders.
4. All cut edges of reinforced TPO and PVC membrane must be sealed with EverGuard® TPO or PVC Cut Edge Sealant.
5. When using bonding adhesive, be sure to use adhesive specific to membrane type.
6. Minimum flashing height is 8".
7. The maximum distance from the wall that horizontal mechanical attachment is installed is 6". When you must go past 6", move the attachment to the vertical substrate.
8. Installation of EverGuard® PVC flashing membrane over asphalt-based substrates must have a separator sheet or approved insulation boards, metal, wood, etc., under the PVC flashing membrane.

## B. Coated Metal Flashings

1. Coated metal flashing allows much of the metal-work used in typical roofing applications to benefit from the security of heat-welded membrane seaming, with a corresponding reduction in required metalwork maintenance during the life of the roofing system.
2. Coated metal shall be formed in accordance with construction details and SMACNA guidelines.
3. Coated metal sections used for roof edging, base flashing, and coping shall be butted together with a 1/4" gap to allow for expansion and contraction. Heat weld a 6" wide unreinforced membrane strip to both sides of the joint, with approximately 1" on either side of the joint left unwelded to allow for expansion and contraction. 2" wide aluminum tape can be installed over the joint as a bond-breaker, to prevent welding in this area.
4. Coated metal used for sealant pans and scupper inserts, and corners of roof edging, base flashing and coping shall be overlapped or provided with separate metal pieces to create a continuous flange condition, and pop-riveted securely. PVC and TPO coated metal flashings shall be stripped in using 6" unreinforced membranes.
5. Coated metal base flashings must be provided with min.

4" wide flanges screwed to wood nailers. Coated metal base flashings must be formed with a 1" cant.

6. Provide a 1/2" hem for all exposed metal edges to provide corrosion protection and edge reinforcement for improved durability.
7. In addition, provide a 1/2" hem for all metal flange edges whenever possible to prevent wearing of the roofing and flashing membranes at the flange edge.
8. Coated metal flashings are nailed to treated wood nailers or otherwise mechanically attached to the roof deck, or to the wall or curb substrate, in accordance with construction detail requirements.
9. When installing coated metal on walls or curbs that completely cover the existing flashing, the flashing does not need to be removed provided that it is in good condition and tightly adhered

## C. Adhered Reinforced Membrane Flashings - Smooth Surface

1. The thickness of the flashing membrane shall be the same as the thickness of the roofing membrane.
2. When using EverGuard® TPO or PVC adhesives, use any one of the following substrates: polyisocyanurate insulation (w/o foil facer), high density wood fiber board, gypsum roof board, gypsum roof Prime, Dens Guard, cured structural concrete absent of curing and sealing compound, untreated OSB, untreated CDX plywood, Type X gypsum board, and dry, sound masonry absent of curing or sealing compounds.
3. Apply bonding adhesive to both the substrate surface and the underside of the flashing membrane, at the rate of 120 sq. ft./gal. which covers both surfaces yielding 60 square feet of finished, mated surface per gallon for solvent-based bonding adhesives, and at the rate of 200 sq. ft./gal. covering both surfaces yielding 100 square feet of finished, mated surface area per gallon for water-based bonding adhesive. Solvent-based adhesive must be allowed to dry until tacky to the touch before mating flashing membrane. Water-based adhesive must be allowed to dry completely to the touch; install the flashing within one hour of drying.
4. Apply the adhesive only when the adhesive and outside temperatures are above 40°F and rising. Application temperatures above 50°F are recommended to allow easier adhesive application.
5. Carefully position the membrane flashing prior to application to avoid wrinkles and buckles.
6. Heat-weld all laps in EverGuard® smooth-reinforced flashing membrane in accordance with heat welding guidelines.
7. Porous substrates may require double application of adhesive.

# Mechanically Attached Installation Specification

TPO & PVC

8. For extended guarantee lengths, separate counterflashing or cap flashing is required; exposed termination bars are not acceptable.
  9. Alternatively, the Freedom® System can be used for flashings. Consult the Freedom® section for installation instructions.
  10. Also available are Corner Curb Wraps, consisting of a pre-formed combination corner and flashing pieces that are 12" in height and can be ordered in various lengths. These pre-fabricated corners can be configured to fit 12"x 12", 18" x 18", 24" x 24" and 30" x 30" curb flashings. They may be fully adhered or dry hung in place and only require a 1" weld.
- D. Adhered Reinforced Membrane Flashings - Fleece-Back
1. Apply bonding adhesive to the substrate at the rate of 100 sq. ft./gal for water-based adhesive.
  2. The bonding adhesive must remain wet to the touch for one surface applications.
  3. Apply the adhesive only when the outside temperature is above 40°F. Application temperatures above 50°F are recommended to allow easier adhesive application.
  4. When installing fleece-back membranes to a vertical surface, the material should have top edge termination installed immediately to avoid slippage.
  5. Non-selvage edge laps in EverGuard® Fleece-Back flashing membrane are made by butting adjacent sheets and heat welding an 8" wide strip of EverGuard® PVC or EverGuard® TPO Flashing membrane over joint. All cut edges of TPO and PVC reinforced membranes must be sealed with EverGuard® TPO or PVC Cut Edge Sealant.
  6. For extended guarantee lengths, separate counterflashing or cap flashing is required; exposed termination bars are not acceptable.
- E. Loose Reinforced Membrane Flashing
1. For extended guarantee lengths, separate counterflashing or cap flashing is required; exposed termination bars are not acceptable.
  2. Carefully position the EverGuard® smooth reinforced flashing membrane prior to application to avoid wrinkles and buckles.
  3. All laps in EverGuard® smooth reinforced flashing membrane shall be heat welded in accordance with heat welding guidelines.
  4. Maximum flashing height is 24" unless incremental attachment is used.
- F. Unreinforced Membrane Flashings
1. Unreinforced membrane is used as a field-fabricated penetration/reinforcement flashing only where pre-formed corners and pipe boots cannot be properly installed.
  2. Penetration flashings constructed of unreinforced membrane is typically installed in two sections, a vertical piece that extends up the penetration, and a horizontal piece that extends onto the roofing membrane. The two pieces are overlapped and heat-welded together.
  3. The unreinforced vertical membrane flashing may be adhered to the penetration surface. Apply bonding adhesive to both the penetration surface and the underside of the flashing membrane, at the rate of 120 sq. ft./gal. which covers both surfaces yielding 60 square feet of finished, mated surface area per gallon for solvent-based bonding adhesives, and at the rate of 200 sq. ft./gal. covering both surfaces yielding 100 square feet of finished, mated surface area per gallon for water-based bonding adhesive. Coverage rates will vary depending on substrate. Solvent-based adhesive must be allowed to dry until tacky to the touch before flashing membrane application. Water-based adhesive must be allowed to dry completely to the touch; install the flashing within one hour of drying.
  4. Finish the penetration with Water Block between the pipe and the membrane, install clamping band, and caulk.
- G. Roof Edging
1. Roof edge flashing is applicable for both gravel stop/drip edge conditions as well as exterior edges of parapet walls.
  2. Flash roof edges with coated metal flanged edging with minimum 3" wide flange nailed 4" on center into wood nailers and heat weld 8" membrane strip to metal flanges and field membrane.
  3. Metal roof edging must be provided with a continuous metal hook strip to secure the lower fascia edge. Secure the continuous hook strip to the building a minimum of 12" on center.
  4. Alternatively, flash roof edges with a 2-piece snap-on fascia system, adhering roof membrane to metal cant with bonding adhesive and face nailing the membrane 8" on center prior to installing the snap-on fascia.
  5. Galvanized-based metal edging may be flashed using EverGuard® TPO Cover Strip after priming both the metal and the TPO membrane for guarantee lengths up to 15 years. Allow approximately 3" of tape to cover the metal edge with the remaining 3" of tape onto the TPO membrane. Caulk all corners, tape overlaps and T-joints with EverGuard® caulking or TPO Cut Edge Sealant per published standard EverGuard® details. Caulk

# Mechanically Attached Installation Specification

## TPO & PVC

the back edge of the tape with EverGuard® Caulking when slope exceeds 1" in 12".

6. Flash roof edge scuppers with a scupper insert of coated metal or EverGuard® pre-fab coated metal scupper that is mechanically attached to the roof edge and integrated as part of the metal edging.

### H. Parapet and Building Walls

1. Flash walls with loose-applied membrane flashing; membrane flashing applied to the wall substrate with bonding adhesive; or with coated metal flashing fastened with DRILL-TEC™ fasteners 4" on center to wood nailers.
2. Secure membrane flashing at the top edge with a termination bar. Apply water-block between the wall surface and membrane flashing underneath all termination bars. Exposed termination bars shall be mechanically fastened 6" on center; termination bars that are counterflashed shall be fastened 12" on center.
3. Roof membrane must be mechanically attached along the base of walls that are flashed with membrane flashing with screws and plates/termination bar at a fastener spacing in accordance with in-lap attachment requirements, with a 12" on center maximum spacing.
4. Metal counterflashings with fully adhered membrane wall flashings are required on 20-year warranties. All termination bars, either exposed or covered, must be sealed with caulking.
5. Flash wall scuppers with a scupper insert of coated metal that is mechanically attached to the wall and integrated as part of the wall flashing. Refer to scupper section for other detail options.
6. Maximum flashing height without intermediate fastening:
  - 24" - Loose-Applied Flashing
  - 54" - Adhered Flashing
7. Metal cap flashings shall have continuous cleats or be face-fastened 12" o.c. on both the inside and outside of the walls.

### I. Round and Square Tube Penetrations

1. Four options are available for penetration flashings. These are stepped pipe boots, open pipe boots, square tube wraps and field fabrication with unsupported membrane and target.
2. All flashings require the installation of a stainless steel draw band around the top of the flashing. Seal the top edge with Water Block and add draw band with caulking.
3. Roof membrane must be mechanically attached at the base of each penetration with screws and plates a maximum of 12" on center, with a minimum of four fasteners per penetration.

### J. Irregularly-Shaped Penetrations

1. Flash irregularly shaped penetrations with flanged sealant pans formed of coated metal, secured to the deck through the roof membrane with screws 6" on center, a minimum of two per side.
2. Strip in metal flanges and the vertical pop riveted seam with 8" wide membrane flashing strips heat welded to both the roof membrane and the metal flanges.
3. Fill sealant pans with EverGuard® 2-part Pourable Sealant. Fill sealant pans with non-shrink quick-set grout, and top off sealant pans with a 2" minimum thickness of EverGuard® 2-part Pourable Sealant.
4. Pre-formed sealant pans made of PVC and TPO are available.
  - a. PVC. Installation of pre-formed PVC sealant pans require the flange of the PVC sealant pan to be fastened with a minimum of 4 fasteners per penetration. A PVC membrane target is installed around the base of the sealant pan over the flanges of the PVC sealant pan and heat welded to the flanges. Install the fasteners near the outside edge of the flanges to allow for proper heat welding of the target. The outside edge of the target membrane is heat welded to the field membrane.
  - b. TPO. Installation of pre-formed TPO sealant pans require field membrane securement around the penetration. A minimum of 4 system appropriate screws and plates are required around the penetration. A membrane target must be installed prior to the installation of the TPO sealant pan if the location of the plates do not allow for a continuous 2" weld of the TPO sealant pan flange. Properly heat-weld the flange of TPO sealant pan to the field/target membrane.
  - c. If the sealant pan is cut to install around the penetration, the cut must be stripped-in with a minimum 4" wide unreinforced membrane. The unreinforced strip-in membrane must extend a minimum of 2" beyond the outside edge of the sealant pan flange and be fully welded.
  - d. Prior to filling the TPO sealant pan, the inside vertical pan sides must be primed with GAF TPO primer. Fill the base of the pans with non-shrink grout and top with a minimum 2" thickness of GAF Two Part Pourable Sealer.
  - e. Reinforced targets must be sealed as system appropriate with EverGuard® Cut Edge Sealant

### K. Curbs

1. Flashings can be done two different ways, either with adhesive applied to the membrane and substrate or

# Mechanically Attached Installation Specification

## TPO & PVC

loose applied up to 24" high. EverGuard® Coated Metal flashings shall be fastened at 4" o.c.

2. Secure membrane flashing at the top edge with a termination bar, flat slip or counterflashing. Apply water-block between the curb surface and membrane flashing. Exposed termination bars shall be mechanically fastened 6" on center; termination bars that are counterflashed shall be fastened 12" on center. If wood is present at the top of the curb, install ring shanks 12" on center. This can be used in lieu of the bar if nailed on the top or preferably the back side of the wood.
3. Roof membrane must be mechanically attached along the base of curbs and ducts that are flashed with membrane flashing with screws and plates/termination bar at 12" on center.
4. Metal counter flashing may be needed for extended length warranties. All termination bars must be sealed with EverGuard® Caulking.

### L. Expansion Joints

1. Install expansion joint covers at all flat type and raised curbed type expansion joint conditions. There currently three types of expansion joints approved for EverGuard® Systems. There are two prefabricated expansion joints one each for TPO and PVC. Also TPO and PVC can also be field fabricated to meet expansion joint needs. For PVC any prefabricated expansion joint metal nailing strips must be fastened to wood nailers, curbs or secured to walls with appropriate nails or EverGuard® DRILL-TEC™ fasteners.
2. Roof membrane must be mechanically attached along the base of raised curb expansion joints with screws and plates a minimum of 12" on center.
3. Expansion joint bellows must be twice the width of the expansion joint opening to allow for proper expansion/contraction.
4. Metal nailing strip must be set in Water Block and secured with fasteners and neoprene washers fastened 6" o.c.

### M. Roof Drains

1. Roof drains must be fitted with compression clamping rings and strainer baskets. Both original-type cast iron and aluminum drains, as well as retrofit-type cast aluminum and molded plastic drains, are acceptable.
2. Roof drains must be provided with a min. 36" x 36" sumped area if possible. Slope of tapered insulation within the sumped area, shall not exceed 4" in 12".
3. Extend the roofing membrane over the drain opening. Locate the drain and cut a hole in the roofing membrane directly over the drain opening. Provide a 1/2"

membrane flap extending past the drain flange into the drain opening. Punch holes through the roofing membrane at drain bolt locations.

4. For cast iron and aluminum drains, the roofing membrane must be set in a full bed of Water Block on the drain flange prior to securement with the compression clamping ring. Typical Water Block application rate is one 10.5 oz. cartridge per drain.
5. For fleece-backed roof membrane applications, the fleece-backed membrane is cut just short of the drain flange. A separate smooth reinforced membrane drain flashing sheet is heat welded to the roofing membrane and set into the drain above in a full bed of Water Block and secured as above.
6. Do NOT locate lap seams within the sump area. Where lap seams must be located within the sump area, a separate smooth reinforced membrane drain flashing a minimum of 12" larger than the sump area must be installed. The membrane flashing shall be heat welded to the roof membrane. Alternately, if the seam does not run under the clamping ring, it can be covered with a 6" wide reinforced membrane strip heat welded to the membrane.
7. Tighten the drain compression clamping ring in place.

### N. Scuppers

1. Coated metal roof edge scuppers must be provided with a min. 4" wide flange nailed to wood nailers, with hemmed edges and secured with continuous clips in accordance with the gravel stop assembly.
2. Coated metal wall scuppers must be provided with 4" wide flanges, with additional corner pieces pop-rieveted to the flanges to create a continuous flange. All flange corners must be rounded.
3. Install wall scuppers over the roof and flashing membrane and secure to the roof deck/wall with DRILL-TEC™ fasteners 6" on center, a minimum of 2 fasteners per side.
4. All corners must be reinforced with EverGuard® PVC or EverGuard® TPO Universal Corners or field fabricated from EverGuard® unreinforced materials.
5. Strip in scupper with flashing membrane target sheet.
6. Alternately, a wall scupper box may be field flashed using unreinforced flashing membrane heat welded to membrane on the wall face and roof deck and terminated on the outside wall face with a termination bar, Water Block, and caulk.
7. EverGuard® TPO has prefabricated scuppers in standard and custom sizes available. Consult your Territory Manager or local distributor for details..



# Mechanically Attached Installation Specification

## TPO & PVC

### O. Heater Stacks

1. Field-fabricated two-piece membrane flashings of EverGuard® unreinforced flashing are typically installed at heater stacks. EverGuard® TPO and PVC have coned type prefabricated pipe flashing that may work in this instance. If not then field fabricated membrane flashings of EverGuard® TPO UN-55 or EverGuard® PVC UN-80 may be used. The temperature of any heater stack that comes into contact with the EverGuard® membrane should not exceed 160°F.
2. Heat stacks must be equipped with either cone-shaped or vertical tube-type flashing sleeves so that the membrane flashing is not directly in contact with the heater stack.
3. Mechanically attach the roof membrane to the structural deck with DRILL-TEC™ screws and plates around the penetration base prior to flashing installation.
4. All stack flashings must be secured at their top edge by a stainless steel clamping band over Water Block and sealed with EverGuard® Caulking.
5. Field-fabricated membrane flashings may be adhered to the flashing sleeve with EverGuard® TPO or EverGuard® PVC Bonding Adhesive.

### P. Drain Inserts - PVC Only

1. EverGuard® PVC roofing membrane is typically terminated at PVC drain inserts by heat welding the membrane to the PVC coated drain flange (if available), or by securing the membrane between the drain flange and the clamping ring.
2. Drain inserts shall only be used in the event the original drain is damaged and cannot be repaired without complete replacement of the drain.
3. All drains shall be provided with a drain sump of a 36" x 36" minimum dimension, if possible. Fasteners shall be installed 12" on center or a minimum of 4 per penetration.
4. The drain insert is installed on top of the roofing membrane and is secured to the roof deck 6" o.c. with DRILL-TEC™ screws.
5. A separate reinforced membrane drain flashing sheet is heat welded to the roofing membrane. The drain flashing sheet is heat welded to a compatible drain flange.
6. Install the drain clamping ring if applicable.
7. All drains shall be provided with a strainer basket.

### Q. Wood Support Blocking

1. Wood support blocking, typically 4" x 4", is usually installed under light-duty or temporary roof-mounted equipment, such as electrical conduit, gas lines, condensation and drain lines.

2. Install wood support blocking over a protective layer of EverGuard® PVC or TPO membrane or EverGuard® Walkway Pad. Place wood blocking on oversized slip sheet, fold two sides vertically, and fasten with roofing nails into the blocking.

### R. Satellite Dish Support Bases

1. Install satellite dish support bases over a protective layer of EverGuard® Walkway Pad.

### S. Lightning Suppression Clips

1. Secure lightning suppression clips to the roof surface by means of 2" wide EverGuard® PVC or EverGuard® TPO Flashing membrane strips heat welded to the roof membrane.

## 3.13 Traffic Protection

- A. Walkway rolls must be installed at all roof access locations including ladders, hatchways, stairs and doors. Install walkway rolls at other designated locations including roof-mounted equipment work locations and areas of repeated rooftop traffic.
- B. Walkway rolls must be spaced 6" to allow for drainage.
- C. Heat weld walkway rolls to the roof membrane surface continuously around the walkway pad perimeter.
- D. TPO walkway rolls may also be installed with TPO primer and 3" seam tape. First, roll or brush the TPO primer on the back of the TPO pad along the edges and down the middle of length of the pad. Clean and prime the roof membrane where the pad will be installed. Install tape to the back of the pad where cleaned (edges and middle) and roll in with a silicone hand roller. Remove the release paper and install the taped pads directly onto the roof membrane. Secure the pads by rolling into place.

## 3.14 Temporary Closures

- A. The roofing installation must be made watertight at the end of each day's activity to prevent water infiltration into the completed roofing system installation.
- B. Complete all flashings and terminations as the roofing installation progresses.
- C. At the edge of the completed roofing system installation, extend the roofing membrane a minimum of 6" beyond the edge. Seal the roofing membrane to the surrounding deck or substrate surface with hot asphalt or foam sealant.
- D. Remove all temporary night seal materials prior to continuing with the roof installation and dispose of properly.

## 3.15 Field Quality Control

- A. Inspect completed roof sections on a daily basis. It is the contractor's responsibility to probe all heat-welded seams and perform an adequate number of seam cuts to ascertain seam consistency.

# Mechanically Attached Installation Specification

TPO & PVC

- B. Immediately correct all defects, irregularities, and deficiencies identified during inspections. All voids that are found must be patched over per specifications. Do NOT reweld seam voids more than 24 hours after initial welding of the seam.
- C. Remedial work shall be performed with like materials and in a manner consistent with the balance of the roofing installation so as to minimize the number of repair patches.
- D. Excessive patchwork will require replacement of the entire affected membrane section from lap to lap.

## 3.16 Cleaning

- A. Remove bonding adhesive, bituminous markings and other contaminants from finished surfaces. In areas where finished surfaces are soiled by asphalt or any other source of soiling caused by work of this or other sections, consult manufacturer of surfaces for cleaning advice and conform to those instructions.
- B. Cut out and remove any sheet membrane contaminated with solvent-based adhesive, bituminous markings, and other contaminants from finished surface. Repair sheet damage by first cleaning the area with an all-purpose cleaner, then rinse off soapy residue. Reactivate membrane using the appropriate EverGuard® cleaner, wiping with a damp (not saturated) rag. Complete repair by installing a patch of like material to specific system requirements.

## 3.17 Maintenance

- A. Upon completion of the roofing system, the owner should establish a semi-yearly inspection and maintenance program in accordance with standard good roofing practice guarantee requirements.
- B. Repair cuts, punctures and other membrane damage by cleaning membrane (see section 3.11.E), followed by heat welding a membrane repair patch of sufficient size to extend a minimum of 2" beyond the damaged area. If heat welding to the top surface of the existing membrane is ineffective, the patch must be heat welded to the underside of the existing sheet after proper preparation.
- C. Any damage to adhered membrane areas or at locations of mechanical attachment shall be repaired so that the repaired area remains fully adhered or mechanically attached.

# NOTES