

# Historical Affairs and Landmark Review Board

Arlington County, Virginia

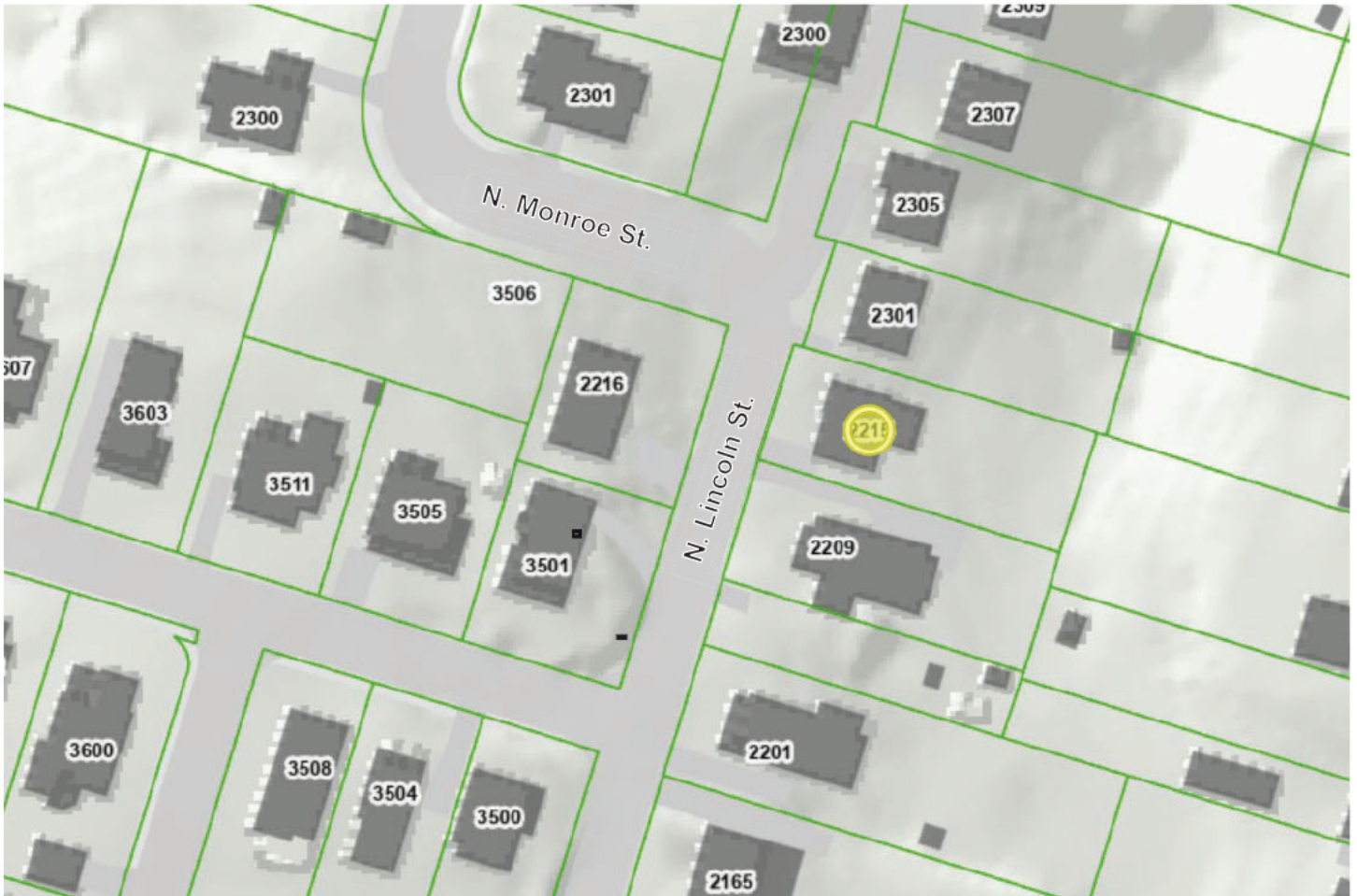

HALRB Meeting October 16, 2024, CoA 24-23

2215 N. Lincoln St.: Request to install solar panels.



SolarEnergyWorld

Tomorrow's Energy Today



## **Ellen Fishman**

2215 N Lincoln St  
Arlington, VA 22207

Proposed System Size:  
(20) Roof-Mounted Longi400 Solar Panels  
(1) Tesla Solar Inverter  
Topspeed Racking System  
8.000kW-DC 7.600kW-AC Output





SolarEnergyWorld

Tomorrow's Energy Today



Proposed Inverter / Utility Disconnect Location



SolarEnergyWorld  
Tomorrow's Energy Today

Roof Condition



View from Highest Point







SolarEnergyWorld  
Tomorrow's Energy Today

Roof Structure From Attic



Ground Level Views





Ground Level Views Cont.





SolarEnergyWorld  
Tomorrow's Energy Today

### Panel Room – Basement







SolarEnergyWorld  
Tomorrow's Energy Today

### Examples of Completed Look



Examples of Completed Look Cont.







SolarEnergyWorld  
Tomorrow's Energy Today

### Examples of Completed Look Cont.









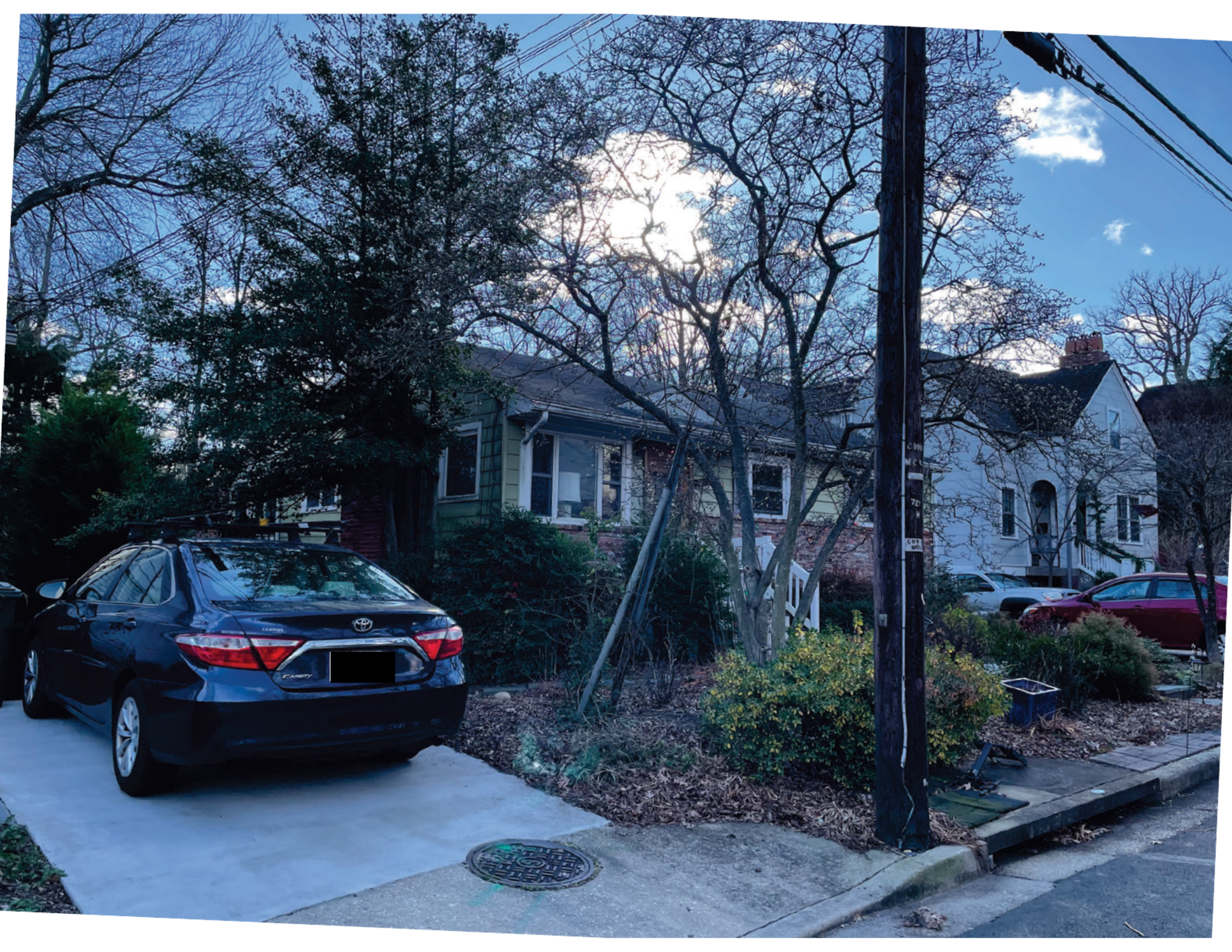



SolarStack on R2

David C. Hernandez  
 Digitally signed by David C. Hernandez  
 Date: 2024.08.23 12:09:38 -04:00

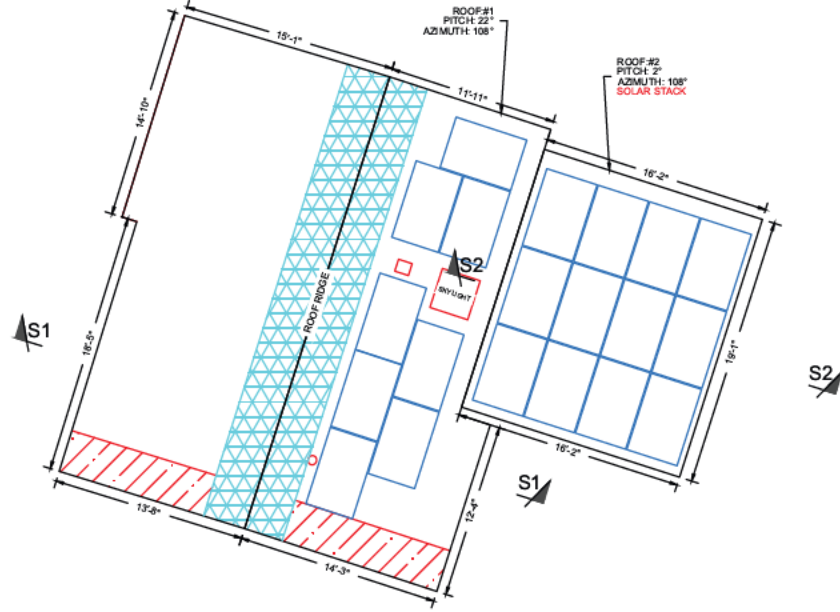

- KEY** FIRE SAFETY ZONE
- 3' PATHWAYS FROM LOWEST ROOF EDGE TO RIDGE PROVIDED PER R324.6.1
  - 16" PATHWAYS PROVIDED ON BOTH SIDES OF RIDGE PER R324.6.2

PLAN VIEW TOTAL ROOF AREA: 1266 SQFT  
 SOLAR ARRAY AREA: 420.40 SQFT  
 THE SOLAR ARRAY IS 33.2% OF THE PLAN VIEW TOTAL ROOF AREA

- NOTES:**
1. THE SYSTEM SHALL INCLUDE (20) LONGI LR5-54HAB-400M.
  2. SNAPRACK TOPSPEED WILL BE INSTALLED IN ACCORDANCE WITH SNAPRACK INSTALLATION MANUAL.
  3. REFER TO STRUCTURAL DRAWING FOR SECTIONS MARKED AND ADDITIONAL NOTES.

**SOLAR PANEL LAYOUT**  
 Scale: 1/8" = 1'-0"





**Solar Energy World**  
 Because Tomorrow Matters

Solar Energy World LLC  
 1480 Switzer Lane  
 Laurel, MD 20707  
 (888) 487-3233

This drawing is the property of Solar Energy World LLC. The information herein contained shall be used for the sole benefit of Solar Energy World. It shall not be disclosed to others outside the recipient's organization, in whole or in part, without the written permission of Solar Energy World, except in connection with the sale and use of the respective Solar Energy equipment.

Authority Code	
International Residential Code (IRC) 2018	
Authority Code	
National Electrical Code (NEC) 2017	
Wind Speed	30 PSF
Wind Speed	115 MPH
Panel Type	
(20) LONGI LR5-54HAB-400M	
Inverter Type	
(1) Tesla 1538000-xx-y (7.6 kW)	
DC System Size	8.000 kW
AC System Size	7.600 kW
Installer Name	
Ellen Fishman	
2215 N Lincoln St	
Arlington, VA 22207	
Panel Type	
Dividend	
City	Arlington
State	Dominion VA
Panel Name	
Solar Panel Layout	
Code	CB
Date	August 22, 2024
Status	AS NOTED
Version	VA20208
Sheet	A-1



### STRING KEY

- String #1 —  TESLA MC1-2
- String #2 —

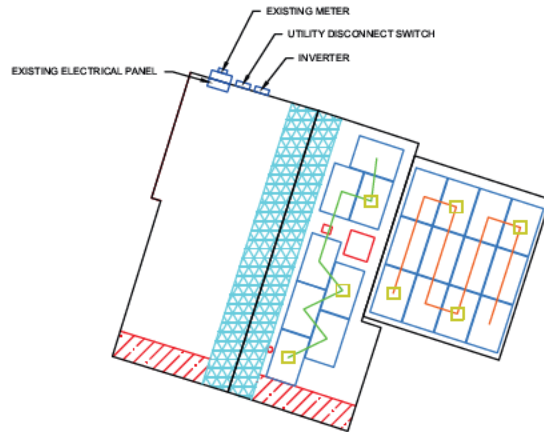

### EQUIPMENT LOCATION PLAN

Scale: NTS

**NOTE:**

EQUIPMENT LOCATION PLAN IS APPROXIMATE. EXACT LOCATION TO BE VERIFIED WITH INSTALLATION CREW AND HOME OWNER AT THE TIME OF INSTALLATION.

David C. Hernandez  
Digitally signed by David C. Hernandez  
Date: 2024.08.23 12:09:38 -04:00





**Solar Energy World**  
Because Tomorrow Matters

Solar Energy World LLC  
14880 Switzer Lane  
Lanham, MD 20707  
(888) 487-3233

This drawing is the property of Solar Energy World LLC. The information herein contained shall be used for the sole benefit of Solar Energy World. It shall not be disclosed to others outside the recipient organization, in whole or in part, without the written permission of Solar Energy World, except in connection with the sale and use of the respective Solar Energy equipment.

Authority Code	
International Residential Code (IRC) 2018	
National Code	
National Electrical Code (NEC) 2017	
Wind Speed	Roof Load
115 MPH	30 PSF
Panel Type	
(20) LONGi LR5-54HABB-400M	
Inverter Type	
(1) Tesla 1538000-xx-y (7.6 kW)	
DC System Size	AC System Size
8.000 kW	7.600 kW
Project Name	
Ellen Fishman 2215 N Lincoln St Arlington, VA 22207	
Project Owner	
Dividend	
City	State
Arlington	Dominion VA
Drawing Name	
Equipment Location Plan	
Revision	Date
CB	August 22, 2024
Notes	Sheet
AS NOTED	VA20208 E-1

# DAVID C. HERNANDEZ, PE

513-418-8812 

4912 Prospect Ave., Blue Ash OH 45242 

davehernandezpe@gmail.com 

DATE: August 23, 2024

RE: 2215 N Lincoln St, Arlington, VA 22207, USA

To Whom It May Concern,

As per your request, Exactus Energy has inspected the structure and has conducted a structural assessment of the building at the above address.

PV solar panels are proposed to be installed on roof areas as shown in the submitted plans. The panels of Roof 1 are clamped and attached to the roof decking with a rail-less mounting system while the panels of Roof 2 are clamped to rails which are attached to the roof with 8" Solar Stack Pedestal mounting system adhered with ICP POLYSET AH-160 foam adhesive. The PV system (PV modules, racking, mounting hardware, etc.) shall be installed according to the manufacturer's approved installation specifications. The Engineer of Record and Exactus Energy claim no responsibility for misuse or improper installation.

It was found that the roof structures satisfactorily meet the applicable standards included in the 2018 Virginia Uniform Statewide Building Code, 2018 Virginia Residential Code, and ASCE 7-16 as well as the design criteria shown below:

Design Criteria:

Risk Category	= II
Exposure Category	= B
Wind speed	= 115 mph
Ground snow load	= 30 psf
Roof dead load	= 9 psf
Solar system dead load	= 9.3 psf

Overall, the roof area is structurally adequate to support the PV alteration with no modifications or reinforcements as required.

This letter was completed in accordance to recognized design standards, professional engineering experience, and judgement. Prior to installation, the on-site contractor must notify Exactus Energy if there are any discrepancies, or damages to the members, that was not addressed in the plan set.

If you have any further questions, please do not hesitate to contact me.

David C. Hernandez, PE

Digitally signed by David C. Hernandez,  
Date: 2024.08.23 12:09:38 -04:00







**COMPANY**  
Aug. 23, 2024 01:36

**PROJECT**  
Roof 1.wwb

**Design Check Calculation Sheet**  
WoodWorks Sizer 2019 (Update 4)

**Loads:**

Load	Type	Distribution	Pat-tern	Location [ft]		Magnitude		Unit
				Start	End	Start	End	
D-ROOF	Dead	Full Area	No			9.00 (16.0")		psf
S1	Snow	Partial Area	No	0.00	3.71	23.10 (16.0")		psf
L1	Roof live	Partial Area	No	0.00	3.71	20.00 (16.0")		psf
S2	Snow	Partial Area	No	10.67	14.25	23.10 (16.0")		psf
L2	Roof live	Partial Area	No	10.67	14.25	20.00 (16.0")		psf
S3	Snow	Partial Area	No	3.71	10.67	18.48 (16.0")		psf
D-PV	Dead	Partial Area	No	3.71	10.67	3.00 (16.0")		psf

**Maximum Reactions (lbs), Bearing Capacities (lbs) and Bearing Lengths (in) :**

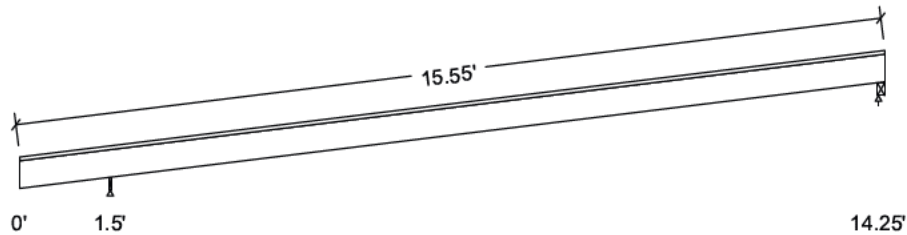

Unfactored:			
Dead	120		97
Snow	221		175
Roof Live	109		85
Factored:			
Total	341		272
Bearing:			
F'theta	475		475
Capacity			
Joist	623		1068
Support	398		1195
Des ratio			
Joist	0.55		0.25
Support	0.86		0.23
Load comb	#3		#3
Length	0.50*		1.50
Min req'd	0.50*		0.50*
Cb	1.75		1.00
Cb min	1.75		1.00
Cb support	1.25		1.25
Fcp sup	425		425

\*Minimum bearing length setting used: 1/2" for end supports and 1/2" for interior supports

**Lumber-soft, S-P-F, No.1/No.2, 2x6 (1-1/2"x5-1/2")**

Supports: All - Lumber-soft Beam, S-P-F No.1/No.2

Roof joist spaced at 16.0" c/c; Total length: 15.75'; Clear span(horz): 1.5', 12.688'; Volume = 0.9 cu.ft.; Pitch: 5/12  
Lateral support: top = continuous, bottom = at supports; Repetitive factor: applied where permitted (refer to online help);

**This section PASSES the design code check.**

**Analysis vs. Allowable Stress and Deflection using NDS 2018 :**

Criterion	Analysis Value	Design Value	Unit	Analysis/Design
Shear	fv = 43	Fv' = 155	psi	fv/Fv' = 0.28
Bending(+)	fb = 1327	Fb' = 1504	psi	fb/Fb' = 0.88
Bending(-)	fb = 78	Fb' = 911	psi	fb/Fb' = 0.09
Deflection:				
Interior Live	0.60 = L/274	0.92 = L/180	in	0.65
Total	1.17 = L/141	1.38 = L/120	in	0.85
Cantil. Live	-0.22 = L/88	0.22 = L/90	in	1.01
Total	-0.43 = L/45	0.32 = L/60	in	1.32

**Additional Data:**

FACTORS:	F/E (psi)	CD	CM	Ct	CL	CF	Cfu	Cr	Cfrt	Ci	LC#
Fv'	135	1.15	1.00	1.00	-	-	-	-	1.00	1.00	3
Fb'+	875	1.15	1.00	1.00	1.000	1.300	-	1.15	1.00	1.00	3
Fb'-	875	1.15	1.00	1.00	0.606	1.300	-	1.15	1.00	1.00	3
Fcp'	425	-	1.00	1.00	-	-	-	-	1.00	1.00	-
E'	1.4 million	1.00	1.00	1.00	-	-	-	-	1.00	1.00	3
Emin'	0.51 million	1.00	1.00	1.00	-	-	-	-	1.00	1.00	3

**CRITICAL LOAD COMBINATIONS:**

Shear : LC #3 = D + S  
 Bending(+): LC #3 = D + S  
 Bending(-): LC #3 = D + S  
 Deflection: LC #3 = D + S (live)  
                   LC #3 = D + S (total)  
 Bearing : Support 1 - LC #3 = D + S  
                   Support 2 - LC #3 = D + S

D=dead S=snow Lr=roof live

All LC's are listed in the Analysis output

Load combinations: ASD Basic from ASCE 7-16 2.4 / IBC 2018 1605.3.1

**CALCULATIONS:**

V max = 255, V design = 237 lbs; M(+) = 837 lbs-ft; M(-) = 49 lbs-ft  
 EIy = 29.12 lb-in<sup>2</sup>

"Live" deflection is due to all non-dead loads (live, wind, snow...)

Total deflection = 1.5 dead + "live"

Bearing: Allowable bearing at an angle F'theta calculated for each support  
 as per NDS 3.10.3

Lateral stability(-): Lu = 13.81' Le = 21.25' RB = 25.0; Lu based on full span

**Design Notes:**

1. Analysis and design are in accordance with the ICC International Building Code (IBC 2018) and the National Design Specification (NDS 2018), using Allowable Stress Design (ASD). Design values are from the NDS Supplement.
2. Please verify that the default deflection limits are appropriate for your application.
3. Continuous or Cantilevered Beams: NDS Clause 4.2.5.5 requires that normal grading provisions be extended to the middle 2/3 of 2 span beams and to the full length of cantilevers and other spans.
4. Sawn lumber bending members shall be laterally supported according to the provisions of NDS Clause 4.4.1.
5. SLOPED BEAMS: level bearing is required for all sloped beams.
6. The critical deflection value has been determined using maximum back-span deflection. Cantilever deflections do not govern design.





COMPANY

PROJECT

Aug. 23, 2024 01:33

Roof 2.wwb

**Design Check Calculation Sheet**  
WoodWorks Sizer 2019 (Update 4)

**Loads:**

Load	Type	Distribution	Pat-tern	Location [ft]		Magnitude		Unit
				Start	End	Start	End	
D-ROOF	Dead	Full Area	No			9.00 (16.0")		psf
S1	Snow	Full Area	No			23.10 (16.0")		psf
D-PV	Dead	Partial Area	No	0.40	15.54	9.30 (16.0")		psf
L1	Dead	Partial Area	No	0.00	0.40	20.00 (16.0")		psf
L2	Dead	Partial Area	No	15.54	15.85	20.00 (16.0")		psf

**Maximum Reactions (lbs), Bearing Capacities (lbs) and Bearing Lengths (in) :**

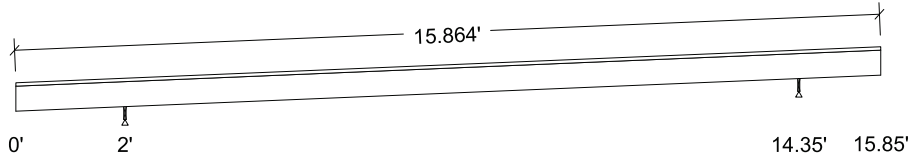

Unfactored:				
Dead		207		190
Snow		254		234
Factored:				
Total		461		424
Bearing:				
F'theta		626		626
Capacity				
Joist		895		821
Support		461		586
Des ratio				
Joist		0.52		0.52
Support		1.00		0.72
Load comb		#2		#2
Length		0.58		0.50*
Min req'd		0.58**		0.50*
Cb		1.65		1.75
Cb min		1.65		1.75
Cb support		1.25		1.25
Fcp sup		425		625

\*Minimum bearing length setting used: 1/2" for interior supports

\*\*Minimum bearing length governed by the required width of the supporting member.

**Lumber-soft, D.Fir-L, No.2, 2x6 (1-1/2"x5-1/2")**

Supports: 1 - Lumber-soft Beam, S-P-F No.1/No.2; 2 - Timber-soft Beam, D.Fir-L No.2;

Roof joist spaced at 16.0" c/c; Total length: 15.88'; Clear span(horz): 2.0', 12.313', 1.5'; Volume = 0.9 cu.ft.; Pitch: 0.5/12

Lateral support: top = continuous, bottom = at supports; Repetitive factor: applied where permitted (refer to online help);

**This section PASSES the design code check.**

**Analysis vs. Allowable Stress and Deflection using NDS 2018 :**

Criterion	Analysis Value	Design Value	Unit	Analysis/Design
Shear	fv = 58	Fv' = 207	psi	fv/Fv' = 0.28
Bending(+)	fb = 1521	Fb' = 1547	psi	fb/Fb' = 0.98
Bending(-)	fb = 192	Fb' = 1101	psi	fb/Fb' = 0.17
Deflection:				
Interior Live	0.44 = L/338	0.82 = L/180	in	0.53
Total	0.95 = L/156	1.24 = L/120	in	0.77
Cantil. Live	-0.17 = L/108	0.20 = L/90	in	0.83
Total	-0.36 = L/50	0.30 = L/60	in	1.20

**Additional Data:**

FACTORS:	F/E (psi)	CD	CM	Ct	CL	CF	Cfu	Cr	Cfrt	Ci	LC#
Fv'	180	1.15	1.00	1.00	-	-	-	-	1.00	1.00	2
Fb'+	900	1.15	1.00	1.00	1.000	1.300	-	1.15	1.00	1.00	2
Fb'-	900	1.15	1.00	1.00	0.712	1.300	-	1.15	1.00	1.00	2
Fcp'	625	-	1.00	1.00	-	-	-	-	1.00	1.00	-
E'	1.6 million	1.00	1.00	1.00	-	-	-	-	1.00	1.00	2
Emin'	0.58 million	1.00	1.00	1.00	-	-	-	-	1.00	1.00	2

**CRITICAL LOAD COMBINATIONS:**

Shear : LC #2 = D + S  
 Bending(+): LC #2 = D + S  
 Bending(-): LC #2 = D + S  
 Deflection: LC #2 = D + S (live)  
                   LC #2 = D + S (total)  
 Bearing : Support 1 - LC #2 = D + S  
                   Support 2 - LC #2 = D + S

D=dead S=snow

All LC's are listed in the Analysis output

Load combinations: ASD Basic from ASCE 7-16 2.4 / IBC 2018 1605.3.1

**CALCULATIONS:**

V max = 345, V design = 318 lbs; M(+) = 959 lbs-ft; M(-) = 121 lbs-ft  
 EIy = 33.27 lb-in<sup>2</sup>

"Live" deflection is due to all non-dead loads (live, wind, snow...)

Total deflection = 1.5 dead + "live"

Bearing: Allowable bearing at an angle F'theta calculated for each support  
 as per NDS 3.10.3

Lateral stability(-): Lu = 12.38' Le = 19.19' RB = 23.7; Lu based on full span

**Design Notes:**

1. Analysis and design are in accordance with the ICC International Building Code (IBC 2018) and the National Design Specification (NDS 2018), using Allowable Stress Design (ASD). Design values are from the NDS Supplement.
2. Please verify that the default deflection limits are appropriate for your application.
3. Continuous or Cantilevered Beams: NDS Clause 4.2.5.5 requires that normal grading provisions be extended to the middle 2/3 of 2 span beams and to the full length of cantilevers and other spans.
4. Sawn lumber bending members shall be laterally supported according to the provisions of NDS Clause 4.4.1.
5. SLOPED BEAMS: level bearing is required for all sloped beams.
6. The critical deflection value has been determined using maximum back-span deflection. Cantilever deflections do not govern design.



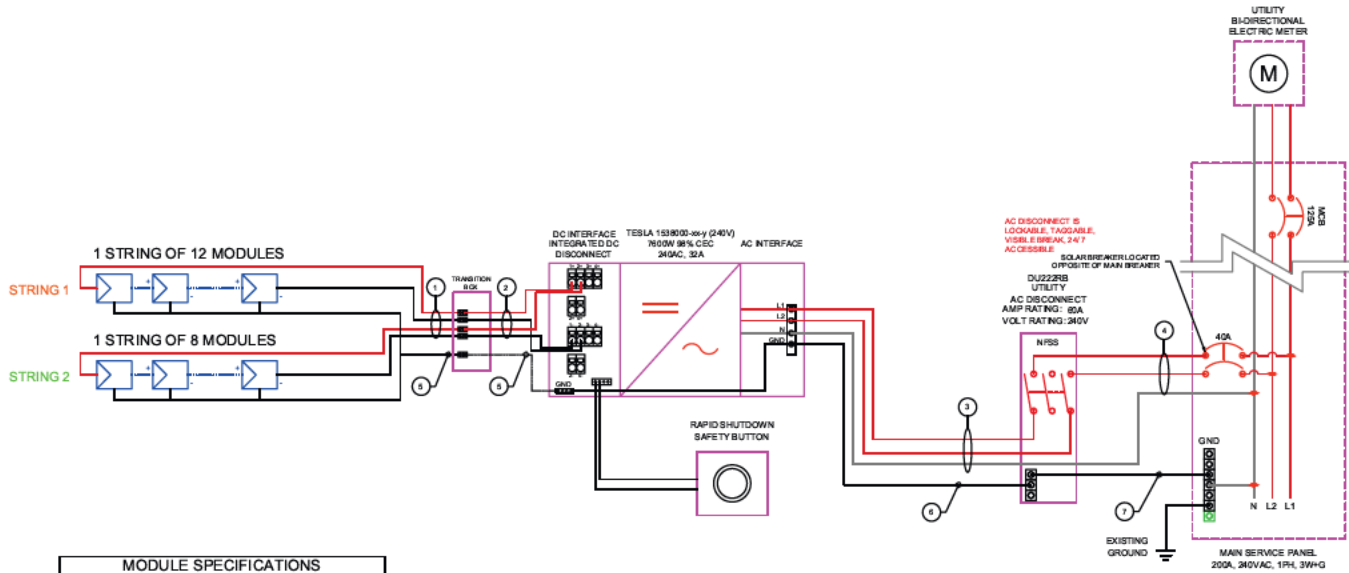
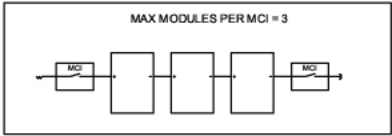

3-LINE DIAGRAM

MODULE SPECIFICATIONS		
MODEL NUMBER	LR5-54HABB-400M	
PEAK POWER	400 W	
RATED VOLTAGE (V <sub>mpp</sub> )	30.94 V	
RATED CURRENT (I <sub>mp</sub> )	12.93 A	
OPEN CIRCUIT VOLTAGE (V <sub>oc</sub> )	37.95 V	
SHORT CIRCUIT CURRENT (I <sub>sc</sub> )	13.72 A	
MAXIMUM SYSTEM VOLTAGE	1000VDC	
INVERTER SPECIFICATIONS		
MODEL NUMBER	1538000-xx-y (7.6 kW)	
MAXIMUM DC VOLTAGE	600 V	
MAXIMUM POWER OUTPUT	7600 W	
NOMINAL AC VOLTAGE	240 VAC	
MAXIMUM AC CURRENT	32 A	
CEC EFFICIENCY	98.0%	
ARRAY DETAILS		
NO. OF MODULES PER STRING	3	12
NO. OF STRINGS	1	1
ARRAY WATTS AT STC	3200	4800
MAX. VOLTAGE	480 V	480 V
690.53 LABEL INFO		
MAX. RATED OUTPUT VOLTAGE (DC)	247.52 V	371.28 V
MAX. SYSTEM VOLTAGE	600 V	600 V
SHORT CIRCUIT CURRENT	15.4	15.4

WIRE/CONDUIT SCHEDULE ARRAY			
TAG	DESCRIPTION	WIRE SIZE/TYPE	NOTES
1	Panel to Transition Box	#10 PV Wire 2KV Rated	
2	Transition Box to DC Disconnect	#10 THHN/THWN-2	
3A	DC Disconnect to Inverter	N/A	INTEGRATED
3	Inverter to AC Disconnect	#6 Cu THHN/THWN-2	
4	AC Disconnect to Interconnection Point	#6 Cu THHN/THWN-2	
5	Equipment Grounding Conductor	#6 Outside Copper Braid	
6	Equipment Grounding Conductor	#6 Cu THHN/THWN-2	
7	Grounding Electrode Conductor	#6 Cu	

GENERAL ELECTRIC NOTES: NEC2017

- EQUIPMENT USED SHALL BE NEW, UNLESS OTHERWISE NOTED.
  - EQUIPMENT USED SHALL BE UL LISTED, UNLESS OTHERWISE NOTED.
  - EQUIPMENT SHALL BE INSTALLED PROVIDING ADEQUATE PHYSICAL WORKING SPACE AROUND THE EQUIPMENT AND SHALL COMPLY WITH NEC.
  - COPPER CONDUCTORS SHALL BE USED AND SHALL HAVE AN INSULATION RATING OF 600V, 90°C, UNLESS OTHERWISE NOTED.
  - CONDUCTORS SHALL BE SIZED IN ACCORDANCE TO THE NEC. CONDUCTORS AMPACITY SHALL BE DE-RATED FOR TEMPERATURE INCREASE, CONDUIT FILL AND VOLTAGE DROP.
  - ALL CONDUCTORS, EXCEPT PV WIRE SHALL BE INSTALLED IN APPROVED CONDUITS OR RACEWAY. CONDUITS SHALL BE ADEQUATELY SUPPORTED AS PER NEC.
  - AC DISCONNECT SHOWN IS REQUIRED IF THE UTILITY REQUIRES VISIBLE-BLADE SWITCH.
  - EXPOSED NON-CURRENT CARRYING METAL PARTS SHALL BE GROUNDING AS PER NEC.
  - LINE SIDE INTER-CONNECTION SHALL COMPLY WITH NEC.
  - SMS MONITORING SYSTEM AND ITS CONNECTION SHOWN IS OPTIONAL. IF USED, REFER TO SMS INSTALLATION MANUAL FOR WIRING METHODS AND OPERATION PROCEDURE.
  - ASHRAE FUNDAMENTAL OUTDOOR DESIGN TEMPERATURES DO NOT EXCEED 47°C IN THE U.S. (PHOENIX, AZ OR PALM SPRINGS, CA)
  - FOR LESS THAN 9 CURRENT-CARRYING CONDUCTORS IN ROOF MOUNTED SUNLIGHT CONDUIT USING THE OUTDOOR TEMPERATURE OF 47°C
  - 10AWG CONDUCTOR ARE GENERALLY ACCEPTABLE FOR MODULES WITH AN I<sub>sc</sub> OF 9.6 AMPS WITH A 15 AMP FUSE.
- WIRE SIZING FOR GCPD  
EX (I<sub>sc</sub>\*1.25)(1.25/# OF STRINGS IN PARALLEL) = WIRE AMPACITY OR USING NEC TABLE 690.8

**Solar Energy World**  
Because Tomorrow Matters

Solar Energy World LLC  
14880 Switzer Lane  
Lanart, MD 20707  
(888) 487-3233

This drawing is the property of Solar Energy World LLC. The information herein contained shall be used for the sole benefit of Solar Energy World. It shall not be disclosed to others outside the licensee organization, in whole or in part, without the written permission of Solar Energy World, except in connection with the sale and use of the respective Solar Energy equipment.

Code Book  
International Residential Code (IRC) 2018

Code Book  
National Electrical Code (NEC) 2017

Wind Speed 115 MPH	Roof Load 30 PSF
-----------------------	---------------------

Model  
(20) LONGi LR5-54HABB-400M

Notes  
(1) Tesla 1538000-xx-y (7.6 kW)

DC System Size 8,000 kW	AC System Size 7,600 kW
----------------------------	----------------------------

Designer  
Ellen Fishman  
2215 N Lincoln St  
Arlington, VA 22207

Checker  
Dividend

City Arlington	State Dominion VA
-------------------	----------------------

Project Name  
Electrical 3-Line Diagram

Sheet No. CB	Date August 22, 2024
-----------------	-------------------------

Scale AS NOTED	Revision VA20208	Panel E-2
-------------------	---------------------	--------------

**CAUTION**  
SOLAR CIRCUIT

**CAUTION**  
PHOTOVOLTAIC POWER SOURCE

LABEL LOCATION:  
CONDUIT (10' SPACING)  
(PER CODE: NEC 690.31 (D)(2))

**WARNING**  
ELECTRIC SHOCK HAZARD  
THE CONDUCTORS OF THIS  
PHOTOVOLTAIC SYSTEM ARE  
UNGROUNDING AND MAY BE ENERGIZED

LABEL LOCATION:  
ALL SOLAR JUNCTION BOXES  
(PER CODE: NEC 690.13 (B))

**WARNING**  
INVERTER OUTPUT CONNECTION  
DO NOT RELOCATE THIS  
OVERCURRENT DEVICE

LABEL LOCATION:  
AC DISCONNECT  
(PER CODE: NEC 705.12 (B)(3)(2))

**MAIN PHOTOVOLTAIC  
SYSTEM DISCONNECT**

LABEL LOCATION:  
SOLAR MAIN DISCONNECT  
(PER CODE: NEC 690.13 (B))

**PHOTOVOLTAIC  
DISCONNECT FOR  
UTILITY OPERATION**

LABEL LOCATION:  
UTILITY DISCONNECT  
(PER CODE: NEC 690.59)

**WARNING**  
AC VOLTAGE = 240V  
MAX FUSE: 40 A  
RATED AC OUTPUT CURRENT: 32.00 A

LABEL LOCATION:  
PV AC DISCONNECT  
(PER CODE: NEC 690.54)

**WARNING**  
DUAL POWER SOURCE  
SECOND SOURCE IS PV SYSTEM

LABEL LOCATION:  
ELECTRICAL PANELS  
(PER CODE: NEC 690.59 & NEC 705.12 (C))



**SOLAR PV SYSTEM EQUIPPED  
WITH RAPID SHUTDOWN**

TURN RAPID SHUTDOWN SWITCH TO THE "OFF" POSITION TO SHUTDOWN PV SYSTEM AND REDUCE SHOCK HAZARD IN ARRAY

LABEL LOCATION:  
DC DISCONNECT  
(PER CODE: NEC 690.56 (C))

 <b>Solar Energy World</b> Because Tomorrow Matters Solar Energy World LLC 1480 Switzer Lane Laurel, MD 20707 (888) 487-3233		
<small>Subject:</small> This drawing is the property of Solar Energy World Inc. The information herein contained shall be used for the sole benefit of Solar Energy World. It shall not be disclosed to others outside the recipient organization, in whole or in part, without the written permission of Solar Energy World, except in connection with the sale and use of the respective Solar Energy equipment.		
<small>Code:</small> International Residential Code (IRC) 2018		
<small>Code:</small> National Electrical Code (NEC) 2017		
<small>Wind Speed:</small> 115 MPH	<small>Wind Load:</small> 30 PSF	
<small>Model:</small> (20) LONGi LR5-54HABB-400M		
<small>Power:</small> (1) Tesla 1538000-xx-y (7.6 kW)		
<small>DC System Size:</small> 8.000 kW	<small>AC System Size:</small> 7.600 kW	
<small>Owner Name:</small> Ellen Fishman 2215 N Lincoln St Arlington, VA 22207		
<small>Project Name:</small> Dividend		
<small>City:</small> Arlington	<small>State:</small> Dominion VA	
<small>Panel Name:</small> Labels		
<small>Project ID:</small> CB	<small>Installation Date:</small> August 22, 2024	
<small>Status:</small> AS NOTED	<small>Permit Number:</small> VA20208	<small>Label:</small> E-3

INFORMATIONAL NOTE: LABELS TO COMPLY WITH NEC 110.21(B)



## Electrical Calculations

1. Conductor sizing per art 690.8 (B) (1)
  - a. Conductor must have 30 deg. C. ampacity = 125 percent continuous current per art 215.2(A)(1)
  - b. conductor must have (after correction for conditions of use continuous current per table 310.16
  - c. Evaluate conductor temperature of terminations per NEC110.14 (C). Ampacity of wire derated for condition of termination must be continuous current\*1.25. All string terminations are rated at 90 deg. C.
  
2. OCP Sizing per art 690.8(B)(1)
  - a. round up to next size per art 240.4(B)
  
3. Conductor sizing per art 690.8 (B) (1)
  - a. Conductor must have 30 deg. C ampacity = 125 percent continuous current per art 215.2(A)(1)
  - b. conductor must have (after correction for conditions of use) continuous current per table 310.16
  - c. Evaluate conductor temperature of terminations per 110.14(C). Ampacity of wire derated for condition of termination must be continuous current\*1.25. All branch terminations are rated at 75 deg. C min.
  
4. OCP Sizing per art 690.8(B)(1)
  - a. round up to next size per art 240.4(B)
  
5. Conductor sizing per art 690.8 (B) (1)
  - a. Conductor must have 30 deg. C ampacity = 125 percent continuous current per art 215.2(A)(1)
  - b. conductor must have (after correction for conditions of use continuous current per table 310.16
  - c. Evaluate conductor temperature of terminations per 110.14(C). Ampacity of wire derated for condition of termination must be continuous current\*1.25. All inverter output terminations are rated at 75 deg. C.
  
6. OCP Sizing
  - a. round up to next size per art 240.4(B)
  
7. Conductor sizing per art 690.8 (B) (1)
  - a. Conductor must have 30 deg. C ampacity = 125 percent continuous current per art 215.2(A)(1)
  - b. conductor must have (after correction for conditions of use continuous current per table 310.16
  - c. Evaluate conductor temperature of terminations per 110.14(C). Ampacity of wire derated for condition of termination must be continuous current\*1.25. All inverter output terminations are rated at 75 deg. C min.

### Wire Size Calculation Data:

Wire Number 1 - inbuilt wire from PV manufacturer company #10 PV WIRE 2KV RATED.  
 Wire Number 2 - #10 Cu PV Wire  
 Wire Number 3 - Inverter to AC Disconnect  
     Max AC Current of inverter X 1.25  
     = 32 x 1.25 = 40A which will be #8 Cu THHN/THWN-2 wire size  
 Wire Number 4 is AC Disconnect to Interconnection Point which will be #8 Cu THHN/THWN-2 wire size  
 Wire Number 5 is Bare Copper Wire #8 Cu  
 Wire Number 6 is Equipment Ground conductor #8 Cu  
 Wire Number 7 is Grounding electrode conductor (GEC) #6 Cu

 <b>Solar Energy World</b> Because Tomorrow Matters <small>Solar Energy World LLC          14800 Switzer Lane          Laurel MD 20707          (888) 487-3233</small>		
<small>This drawing is the property of Solar Energy World Inc. The information herein contained shall be used for the sole benefit of Solar Energy World. It shall not be disclosed to others outside the recipient organization, in whole or in part, without the written permission of Solar Energy World, except in connection with the sale and use of the respective Solar Energy equipment.</small>		
<small>Authority Code</small> International Residential Code (IRC) 2018		
<small>Authority Code</small> National Electrical Code (NEC) 2017		
<small>Wind Speed</small> 115 MPH	<small>Roof Load</small> 30 PSF	
<small>Module</small> (20) LONGi LR5-54HABB-400M		
<small>System</small> (1) Tesla 1538000-xx-y (7.6 kW)		
<small>DC System Size</small> 8.000 kW	<small>AC System Size</small> 7.600 kW	
<small>Designer Name</small> Ellen Fishman 2215 N Lincoln St Arlington, VA 22207		
<small>Project Name</small> Dividend		
<small>City</small> Arlington	<small>State</small> Dominion VA	
<small>Project Name</small> Electrical Calculations		
<small>Project</small> CB	<small>Date</small> August 22, 2024	
<small>Status</small> AS NOTED	<small>Revision</small> VA20208	<small>Sheet</small> E-4

David C. Hernandez  
 Digitally signed by David C. Hernandez  
 Date: 2024.08.23 12:09:38 -04:00

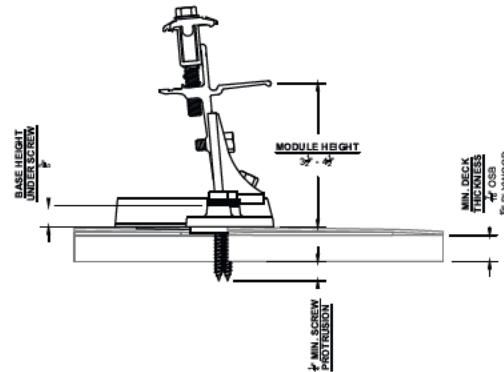
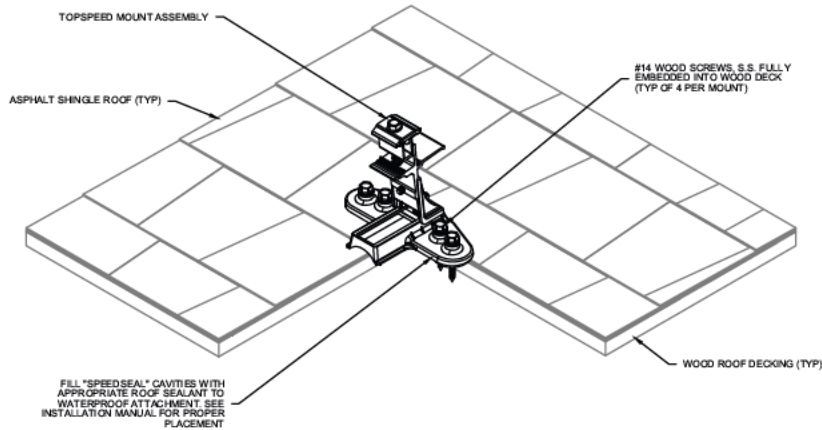

Structural Details		
S1	Rafter	2x6 O.C. 16"

**NOTES:**

- ALL WORK SHALL COMPLY WITH REQUIREMENTS OF INTERNATIONAL RESIDENTIAL CODE (IRC 2018), LOADING CODE (ASCE 7-16), WOOD DESIGN CODE (NDS 2015), AND LOCAL REQUIREMENTS.
- LOAD CRITERIA PER :
  - EXPOSURE CATEGORY "B"
  - GROUND SNOW LOAD,  $P_g = 30$  PSF
  - LATERAL LOAD RISK CATEGORY "I"
  - ULTIMATE DESIGN WIND SPEED = 115 MPH
- SOLAR PANELS AND RACKING SYSTEMS SHALL BE INSTALLED PER MANUFACTURERS RECOMMENDATION.
- FOLLOW ALL LOCAL AND FEDERAL SAFETY REQUIREMENTS.

**STRUCTURAL ATTACHMENT DETAIL**



**Solar Energy World**  
Because Tomorrow Matters

Solar Energy World LLC  
14800 Switzer Lane  
Laurel, MD 20707  
(888) 487-3233

This drawing is the property of Solar Energy World LLC. The information herein contained shall be used for the sole benefit of Solar Energy World. It shall not be disclosed to others outside the recipient organization, in whole or in part, without the written permission of Solar Energy World, except in connection with the sale and use of the respective Solar Energy equipment.

International Residential Code (IRC) 2018	
National Electrical Code (NEC) 2017	
115 MPH	30 PSF
(20) LONGi LR5-54HABB-400M	
(1) Tesla 1538000-xx-y (7.6 kW)	
8.000 kW	7.600 kW
Ellen Fishman 2215 N Lincoln St Arlington, VA 22207	
Dividend	
Arlington	Dominion VA
Structural Attachment Details	
CB	August 22, 2024
AS NOTED	VA20208
<b>S-1</b>	



David C. Hernandez  
 Digitally signed by David C. Hernandez  
 Date: 2024.08.23 12:09:38 -04:00

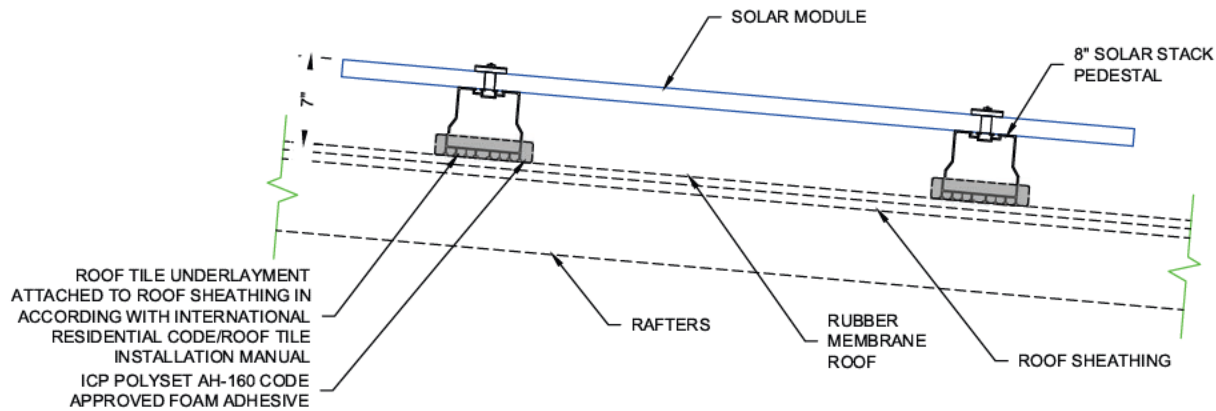

Structural Details		
S2	Rafter	2x6 O.C. 16"

**NOTES:**

- ALL WORK SHALL COMPLY WITH REQUIREMENTS OF INTERNATIONAL RESIDENTIAL CODE (IRC 2018), LOADING CODE (ASCE 7-16), WOOD DESIGN CODE (NDS 2015), AND LOCAL REQUIREMENTS.
- LOAD CRITERIA PER :
  - EXPOSURE CATEGORY "B"
  - GROUND SNOW LOAD,  $P_g = 30$  PSF
  - LATERAL LOAD RISK CATEGORY "I"
  - ULTIMATE DESIGN WIND SPEED = 115 MPH
- SOLAR PANELS AND RACKING SYSTEMS SHALL BE INSTALLED PER MANUFACTURERS RECOMMENDATION.
- FOLLOW ALL LOCAL AND FEDERAL SAFETY REQUIREMENTS.

**STRUCTURAL ATTACHMENT DETAIL**



**Solar Energy World**  
Because Tomorrow Matters

Solar Energy World LLC  
14800 Switzer Lane  
Laurie, MD 20707  
(888) 487-3233

This drawing is the property of Solar Energy World LLC. The information herein contained shall be used for the sole benefit of Solar Energy World. It shall not be disclosed to others outside the recipient organization, in whole or in part, without the written permission of Solar Energy World, except in connection with the sale and use of the respective Solar Energy equipment.

International Residential Code (IRC) 2018	
National Electrical Code (NEC) 2017	
115 MPH	30 PSF
(20) LONGi LR5-54HABB-400M	
(1) Tesla 1538000-xx-y (7.6 kW)	
8.000 kW	7.600 kW
Ellen Fishman 2215 N Lincoln St Arlington, VA 22207	
Dividend	
Arlington	Dominion VA
Structural Attachment Details	
CB	August 22, 2024
AS NOTED	VA20208
<b>S-2</b>	

# Hi-MO **5m**

## LR5-54HPB 400~420M

- Geeignet für dezentrale Energieversorgung
- Überlegene Moduleffizienz durch fortschrittliche Technologie
  - M10 Gallium-dotierter Wafer
  - Integriertes segmentiertes Band
  - Half-Cut-Zelle mit 9 Busbars
- Hervorragende Leistungsfähigkeit bei der Stromerzeugung
- Ästhetisches Erscheinungsbild mit All-Black-Moduldesign

**12** 12 Jahre Produktgarantie auf  
Materialien und Verarbeitung

**25** 25 Jahre zusätzlich lineare  
Leistungsgarantie

### Vollständige Produktzertifizierung

IEC 61215, IEC 61730, UL 61730

ISO9001:2015: ISO Qualitätsmanagementsystem

ISO14001: 2015: ISO Umweltmanagementsystem

ISO45001: 2018: Gesundheit und Sicherheit am Arbeitsplatz

IEC62941: Erhöhte Zuverlässigkeit der Bauartegnung

# LONGI





<b>21.5%</b> MAXIMALE MODULEFFIZIENZ	<b>0~3%</b> LEISTUNGSTOLERANZ	<b>&lt;2%</b> LEISTUNGSDEGRADATION IM ERST JAHR	<b>0.55%</b> LEISTUNGSDEGRADATION IN DEN JAHREN 2-25	<b>HALF-CELL</b> Niedrigere Betriebstemperatur
--	----------------------------------	---	--	---

## Weitere Daten

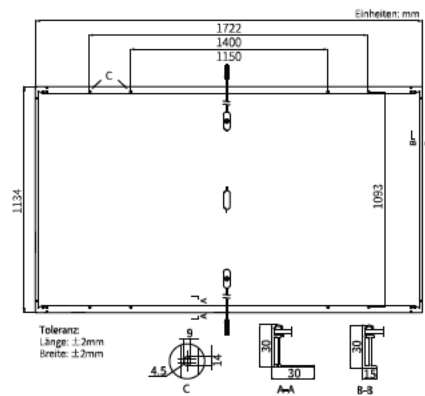
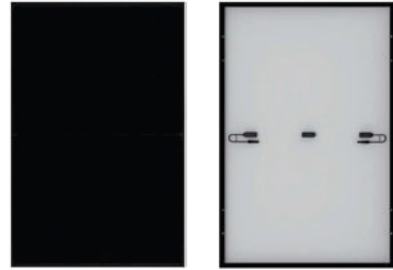
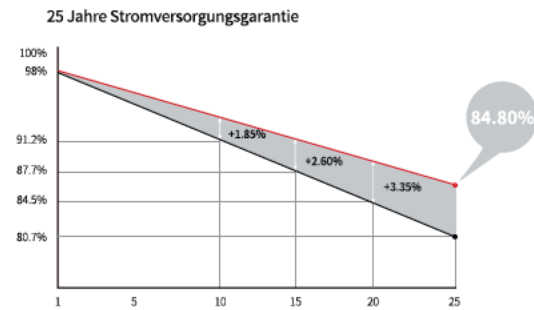

## Mechanische Parameter

Zellenanordnung	108 (6×18)
Anschlussdose	IP68, drei Dioden
Kabel	4mm <sup>2</sup> , 1200mm
Steckverbinder	MC4 EVO2
Glas	Einsseitiges Glas, 3.2mm beschichtetes gehärtetes Glas
Rahmen	Rahmen aus eloxierter Aluminiumlegierung
Gewicht	20.8kg
Abmessungen	1722×1134×30mm
Verpackungen	36 Stück pro Palette / 216 Stück pro 20'GP / 936 Stück pro 40'HC

## Elektrische Eigenschaften

Modultyp	STC: AM1.5 1000W/m <sup>2</sup> 25°C		LR5-54HPB-405M		LR5-54HPB-410M		LR5-54HPB-415M		LR5-54HPB-420M	
	STC	NOCT	STC	NOCT	STC	NOCT	STC	NOCT	STC	NOCT
Testbedingungen										
Maximale Leistung (P <sub>max</sub> /W)	400	299.0	405	302.7	410	306.5	415	310.2	420	313.9
Leerlaufspannung (V <sub>oc</sub> /V)	36.90	34.70	37.15	34.93	37.40	35.17	37.65	35.40	37.89	35.63
Kurzschlussstrom (I <sub>sc</sub> /A)	13.72	11.09	13.78	11.14	13.84	11.19	13.91	11.24	13.97	11.30
Spannung bei maximaler Leistung (V <sub>mp</sub> /V)	30.94	28.74	31.18	28.96	31.42	29.19	31.66	29.41	31.90	29.63
Strom bei maximaler Leistung (I <sub>mp</sub> /A)	12.93	10.40	12.99	10.45	13.05	10.50	13.11	10.55	13.17	10.59
Modulwirkungsgrad (%)	20.5		20.7		21.0		21.3		21.5	

Testunsicherheit für P<sub>max</sub>: ±3%

## Betriebsparameter

Betriebstemperatur	-40°C ~ +85°C
Ausgangsleistungs-Toleranz	0 ~ 3%
V <sub>oc</sub> - und I <sub>sc</sub> -Toleranz	±3%
Maximale Anlagenspannung	1500V Gleichstrom (IEC/UL)
Maximaler Sicherungs-Nennstrom in Reihe	25A
Nennbetriebstemperatur (NOCT)	45±2°C
Sicherheitsklasse	Klasse II
Brandschutzklasse	UL Typ 1 oder 2 IEC Klasse C

## Last

Maximale statische Last vorne	5400Pa
Maximale statische Last hinten	2400Pa
Besteht den Hageltest	25 mm große Hagelkörner bei einer Geschwindigkeit von 23 m/s

## Temp. Koeffizient (STC)

Temperaturkoeffizient von I <sub>sc</sub>	+0.050%/°C
Temperaturkoeffizient von V <sub>oc</sub>	-0.265%/°C
Temperaturkoeffizient von P <sub>max</sub>	-0.340%/°C



## SOLAR INVERTER

**3.8 kW | 7.6 kW**

Tesla Solar Inverter completes the Tesla home solar system, converting DC power from solar to AC power for home consumption. Tesla's renowned expertise in power electronics has been combined with robust safety features and a simple installation process to produce an outstanding solar inverter that is compatible with both Solar Roof and traditional solar panels. Once installed, homeowners use the Tesla mobile app to manage their solar system and monitor energy consumption, resulting in a truly unique ecosystem experience.

### KEY FEATURES

- Built on Powerwall 2 technology for exceptional efficiency and reliability
- Wi-Fi, Ethernet, and cellular connectivity with easy over-the-air updates
- Designed to integrate with Tesla Powerwall and Tesla App
- 3.8 kW and 7.6 kW models available



## SOLAR INVERTER

Tesla Solar Inverter provides DC to AC conversion and integrates with the Tesla ecosystem, including Solar Panels, Solar Roof, Powerwall, and vehicle charging, to provide a seamless sustainable energy experience.



### KEY FEATURES

- Integrated rapid shutdown, arc fault, and ground fault protection
- 2x the standard number of MPPTs for high production on complex roofs
- No neutral wire simplifies installation

### ELECTRICAL SPECIFICATIONS

MODEL NUMBER	1534000-xx-y	1538000-xx-y
OUTPUT (AC)	3.8 kW	7.6 kW
Nominal Power	3,800 W	7,600 W
Maximum Apparent Power	3,328 VA at 208 V 3,840 VA at 240 V	6,656 VA at 208 V 7,680 VA at 240 V
Maximum Continuous Current	16 A	32 A
Breaker (Overcurrent Protection)	20 A	40 A
Nominal Power Factor	1 - 0.9 (leading / lagging)	
THD (at Nominal Power)	<5%	
INPUT (DC)		
MPPT	2	4
Input Connectors per MPPT	1-2	1-2-1-2
Maximum Input Voltage	600 VDC	
DC Input Voltage Range	60 - 550 VDC	
DC MPPT Voltage Range	60 - 480 VDC <sup>1</sup>	
Maximum Current per MPPT ( $I_{mp}$ )	13 A	
Maximum Short Circuit Current per MPPT ( $I_{sc}$ )	15 A	

### PERFORMANCE SPECIFICATIONS

Peak Efficiency	98% at 208 V	98.4% at 208 V
	98.1% at 240 V	98.6% at 240 V
CEC Efficiency	97.5% at 208 V	97.5% at 208 V
	97.5% at 240 V	98.0% at 240 V
Allowable DC/AC Ratio	1.7	
Customer Interface	Tesla Mobile App	
Internet Connectivity	Wi-Fi (2.4 GHz, 802.11 b/g/n), Ethernet, Cellular (LTE/4G) <sup>2</sup>	
AC Remote Metering Support	Wi-Fi (2.4 GHz, 802.11 b/g/n), RS-485	
Protections	Integrated arc fault circuit interrupter (AFCI), Rapid Shutdown	
Supported Grid Types	60 Hz, 240 V Split Phase	
	60 Hz, 208 V Wye	

<sup>1</sup> Maximum current.

<sup>2</sup> Cellular connectivity subject to network operator service coverage and signal strength.

### MECHANICAL SPECIFICATIONS

Dimensions	660 mm x 411 mm x 158 mm (26 in x 16 in x 6 in)
Weight	52 lb <sup>2</sup>
Mounting options	Wall mount (bracket)

<sup>2</sup> Door and bracket can be removed for a mounting weight of 37 lb.

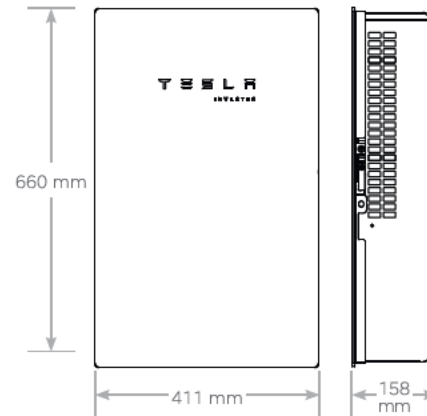

### ENVIRONMENTAL SPECIFICATIONS

Operating Temperature	-30°C to 45°C (-22°F to 113°F) <sup>4</sup>
Operating Humidity (RH)	Up to 100%, condensing
Storage Temperature	-30°C to 70°C (-22°F to 158°F)
Maximum Elevation	3000 m (9843 ft)
Environment	Indoor and outdoor rated
Enclosure Rating	Type 3R
Ingress Rating	IP55 (Wiring compartment)
Pollution Rating	PD2 for power electronics and terminal wiring compartment, PD3 for all other components
Operating Noise @ 1 m	< 40 db(A) nominal, < 50 db(A) maximum

<sup>4</sup> For the 7.6 kW Solar Inverter, performance may be de-rated to 6.2 kW at 240 V or 5.37 kW at 208 V when operating at temperatures greater than 45°C.

### COMPLIANCE INFORMATION

Grid Certifications	UL 1741, UL 1741 SA, IEEE 1547, IEEE 1547.1
Safety Certifications	UL 1741 PVRSS, UL 1699B, UL 1998 (US), UL 3741
Emissions	EN 61000-6-3 (Residential), FCC 47CFR15.109 (a)

## SOLAR SHUTDOWN DEVICE

The Tesla Solar Shutdown Device is part of the PV system rapid shutdown (RSD) function in accordance with Article 690 of the applicable NEC. When paired with the Tesla Solar Inverter, solar array shutdown is initiated by any loss of AC power.



### ELECTRICAL SPECIFICATIONS

Nominal Input DC Current Rating ( $I_{mp}$ )	12 A
Maximum Input Short Circuit Current ( $I_{sc}$ )	15 A
Maximum System Voltage	600 V DC

### RSD MODULE PERFORMANCE

Maximum Number of Devices per String	5
Control	Power Line Excitation
Passive State	Normally open
Maximum Power Consumption	7 W
Warranty	25 years

### COMPLIANCE INFORMATION

Certifications	UL 1741 PVRSE, UL 3741, PVRSA (Photovoltaic Rapid Shutdown Array)
RSD Initiation Method	PV System AC Breaker or Switch
Compatible Equipment	See <i>Compatibility Table below</i>

### ENVIRONMENTAL SPECIFICATIONS

Ambient Temperature	-40°C to 50°C (-40°F to 122°F)
Storage Temperature	-30°C to 70°C (-22°F to 158°F)
Enclosure Rating	NEMA 4 / IP65

### MECHANICAL SPECIFICATIONS

Electrical Connections	MC4 Connector
Housing	Plastic
Dimensions	125 mm x 150 mm x 22 mm (5 in x 6 in x 1 in)
Weight	350 g (0.77 lb)
Mounting Options	ZEP Home Run Clip M4 Screw (#10) M8 Bolt (5/16") Nail / Wood screw

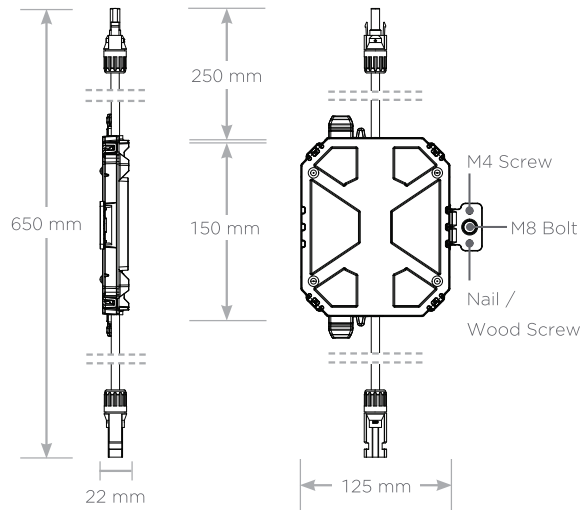

### UL 3741 PV HAZARD CONTROL (AND PVRSA) COMPATIBILITY

Tesla Solar Roof and Tesla/Zep Z5 Arrays using the following modules are certified to UL 3741 and UL 1741 PVRSA when installed with the Tesla Solar Inverter and Solar Shutdown Devices. See the Tesla Solar Inverter Installation Manual for detailed instructions and for guidance on installing Tesla Solar Inverter and Solar Shutdown Devices with other modules.

Brand	Model	Required Solar Shutdown Devices
Tesla	Solar Roof V3	1 Solar Shutdown Device per 10 modules
Tesla	Tesla TxxxS (where xxx = 405 to 450 W, increments of 5)	1 Solar Shutdown Device per 3 modules <sup>1</sup>
Tesla	Tesla TxxxH (where xxx = 395 to 415 W, increments of 5)	1 Solar Shutdown Device per 3 modules
Hanwha	Q.PEAK DUO BLK-G5	1 Solar Shutdown Device per 3 modules
Hanwha	Q.PEAK DUO BLK-G6+	1 Solar Shutdown Device per 3 modules

<sup>1</sup>Exception: Tesla solar modules installed in locations where the max Voc for three modules at low design temperatures exceeds 165 V shall be limited to two modules between MCIs.



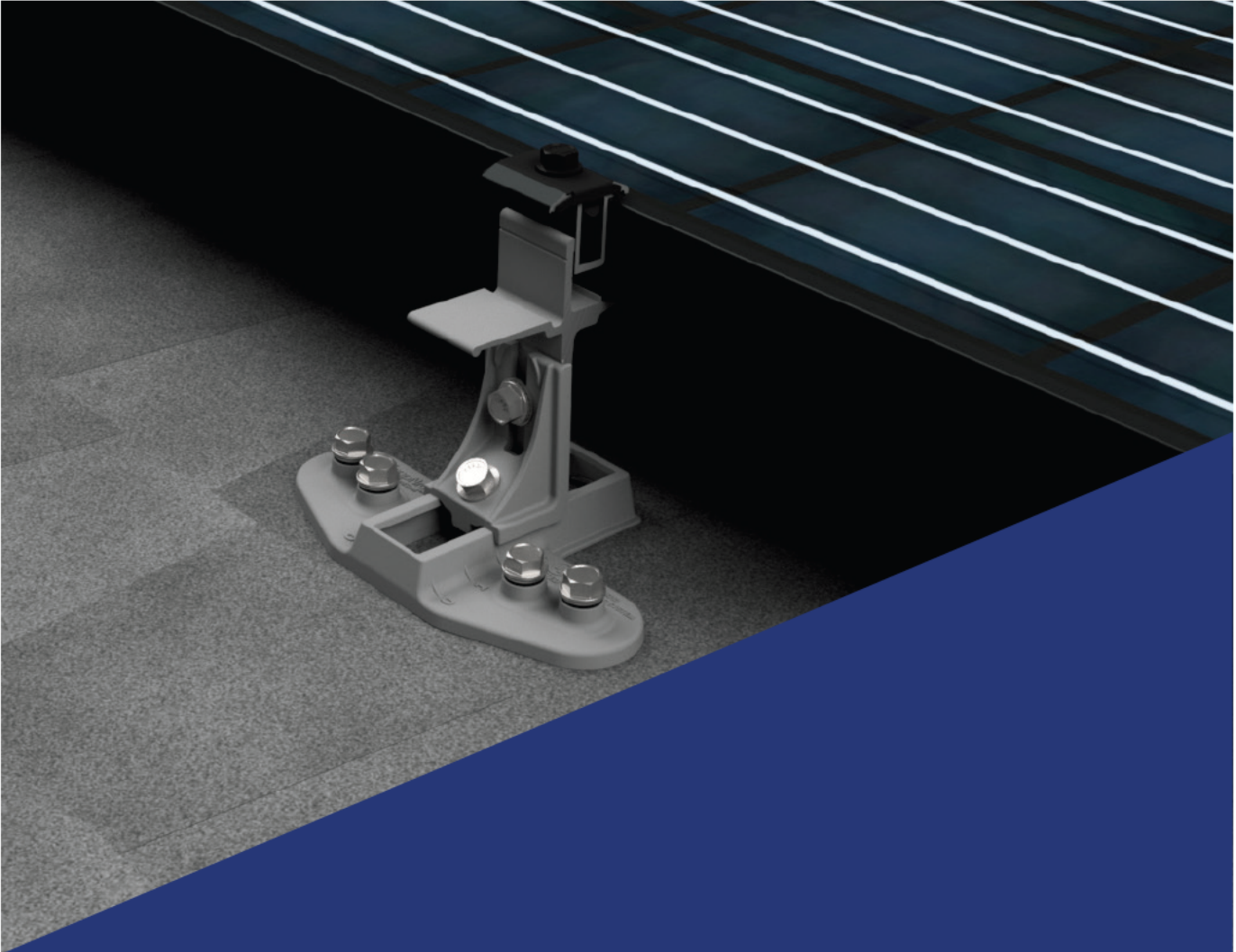

# SnapNrack™

Solar Mounting Solutions

---

## TopSpeed™ Mounting System

Installation Manual

---

[snapnrack.com](http://snapnrack.com)

SnapNrack's primary goal is to provide our customers with the lowest possible installed cost for mounting residential solar modules, without compromising the values the industry has come to expect: ease of use, quality, aesthetics, and safety. Designing with this goal in mind, we are proud to present the SnapNrack TopSpeed™ mounting system with SpeedSeal™ Technology.

SnapNrack has created a ground breaking system combining great features and benefits we are known for, with our TopSpeed™ System and the most up to date technical innovation in the industry, thus reducing parts while driving down labor, material, and total installation costs. Designed to work with standard module frames, achieving UL 2703 Listing for Grounding/Bonding and Fire Classification, providing integrated wire management, aesthetics and our industry leading "Snap-In" features, SnapNrack is providing the simplest and most cost effective solar mounting solution on the market with TopSpeed™ including integrated fasteners and SpeedSeal™ Technology.

### Advantages of Installing the SnapNrack TopSpeed™ System

**Modules are installed with a minimum number of parts**

This elimination of parts leads to a lower estimated system cost for both the installer and home owner.

**Built in Wire Management and Aesthetics**

Extensive wire management solutions have been designed specifically for the system that adapts to multiple possible mounting positions.

The system is designed to be aesthetically pleasing and sturdy with a skirt that provides considerable strength at the leading edge and an elegant look for those seeking high end looking systems.

**SnapNrack TopSpeed™ includes SpeedSeal™ Technology**

SpeedSeal™ Technology features integrated flashing. This eliminates loosening layers of composition and removing nails with a pry bar, leading to less damage to the roof, minimized potential roof leaks, and much faster installs.

**TopSpeed™ Mounts attach Directly to the Decking**

As well as all of the benefits associated with the standard SpeedSeal™ Technology, TopSpeed™ attaches to the roof sheathing and does not require rafter attachment. Simply attaching to the roof sheathing removes the requirement for finding rafters and drilling pilot holes, creating potential rafter misses that can cause leaks.



# Table of Contents



## **Project Plans**

Certification Details . . . . .	4
Component Details . . . . .	5
Pre-Installation Requirements . . . . .	7

## **Installation Steps**

TopSpeed™ Skirt Layout . . . . .	8
TopSpeed™ Mount to Module Installation . . . . .	9
TopSpeed™ Mount Skirt Installation . . . . .	10
Wire Management . . . . .	13
MLPE Attachment . . . . .	16
Module Installation . . . . .	19

## **Grounding Specifications . . . . . 22**

Maintaining the Grounding Bonding When Removing a Module . . . . .	23
Appendix A: List of approved Modules and MLPES . . . . .	25

## Certification Details

---

SnapNrack TopSpeed™ mounting system has been evaluated by Underwriters Laboratories (UL) and Listed to UL Standard 2703 for Grounding/Bonding, and Fire Classification.

### **Grounding/Bonding**

Only specific components have been evaluated for bonding, and are identified as being in the ground path. The TopSpeed™ components that have been evaluated for bonding are the Mount Assembly (Mount Clamp Top, Module Clamp Tower, Angle Bracket), Clamp Assembly, Universal Skirt, Universal Skirt Clamp, Ground Lugs, and Smart Clips.

Universal Skirt Spacers, Mount Channel Nut, and Mount Base are not required to be bonded to the system based on the exceptions in clause 9.1 of UL 2703 1st Ed. Wire management clips are utilized to route conductors away from these components and must be assembled according to the instructions.

This mounting system may be used to ground and/or mount a PV module complying with UL 1703 or UL 61703 only when the specific module has been evaluated for grounding and/or mounting in compliance with the included instructions. See Appendix A for the list of modules tested for use with the TopSpeed™ System for integrated grounding.

Ground Lugs have been evaluated to both UL 467 and UL 2703 Listing requirements. The following ground lugs have been approved for use: SnapNrack model 242-92202, and IlSCO models GBL-4DBT and SGB-4.

The following components have been evaluated for bonding as the fault current ground path: TopSpeed™ Mount Assembly, (Mount Clamp Top, Module Clamp Tower, Angle Bracket), Clamp Assembly, Wire Management Clips, and Ground Lugs. In order to maintain the Listing for bonding, wire management clips must be assembled to route conductors away from parts that have not been evaluated for bonding.

A Listed (QIMS) and Unlisted Component (KDER3) grounding lug, SnapNrack part no. 242-92202, is attached to the module frame flange for the normal attachment of a Grounding Electrode Conductor, which provides bonding within the system and eventual connection to a Grounding Electrode, as required by the U.S. NEC. Details of part no. 242-92202 can be found in Volume 1, Section 4, and Volume 2, Section 2. When this method is used, the grounding symbol is stamped onto the body of the ground lug to identify the grounding terminal.

An alternate method of grounding, a UL Listed (KDER and QIMS) grounding lug, IlSCO (E34440 and E354420) model SGB-4 is attached to the module frame flange. When this method is used, the grounding terminal is identified by the green colored screws of the lug.

An alternate method of grounding, a UL Listed (KDER and QIMS) grounding lug, IlSCO (E34440 and E354420) model GBL-4BDT is attached to the module frame flange through the specified hardware and torque values. When this method is used, the grounding terminal is identified by the green colored set screw of the lug.

An alternate method of grounding, Enphase R/C (QIKH2)(QIMS2) model M250, M215 & C250 is bonded to the Listed PV module frame by the Enphase R/C (QIMS2) Model EFM-XXMM anodization piercing mounting/clamping kit. The total roof-mounted PV system is bonded (modules and microinverters) together and the assembly is bonded to ground through the Enphase R/C (QIMS2) Engage Cables; Model ETXX-240, ETXX-208 or ETXX-277, when properly grounded at the service entrance. R/C (QIMS2), Dynoraxx (E357716) photovoltaic bonding device cat. no. Dynobond is an optional component that may be used with this system. The Dynobond device has been evaluated to provide module to module bonding. The Dynobond device attaches to the frame flange of adjacent modules Listed (QIMS), SnapNrack MLPE Frame Attachment Kit model 242-02151 has been investigated to bond approved MLPE device back plates to frames of modules.

## **Fire**

SnapNrack TopSpeed™ has been investigated for a Class A System Fire Classification for Steep-Sloped and low sloped roofs with Type 1 and Type 2 modules. Because the system was tested at 5 inches above the test roof fixture, TopSpeed™ can be installed without any height restrictions due to System Fire Classification. See Appendix A for potential module-specific height restrictions due to module temperature. The Skirt is considered an optional component with respect to Fire Classification, as SnapNrack TopSpeed™ maintains the same Fire Classification Rating both with and without the skirt.

**NOTE:** Modules with an asterisk\* have a fire rating that is different from Type 1, Type 2 or Type 29. SNR systems have only been evaluated for use with Type 1, Type 2, or Type 29 modules. Modules with a different fire type rating should be considered to not have been evaluated for use with SNR systems with respect to a system fire rating.

## **Inspection Practices**

SnapNrack recommends a periodic re-inspection of the completed installation for loose components, loose fasteners, and any corrosion, such that if found, the affected components are to be immediately replaced.



# Component Details

snapnack.com

## TopSpeed™ Structural Components



### TopSpeed™ Mount

SnapNrack TopSpeed™ Mount assembly including SpeedSeal™ base, clamp top, and (4) SnapNrack #14 SS Wood Screws with 1/2" Hex Head.



### TopSpeed™ Clamp

SnapNrack TopSpeed™ Clamp assembly including including Link bottom, Link top, and springs.



### Universal Skirt

SnapNrack Universal Skirt in double portrait or single landscape lengths.

## Wire Managements Components



### Skirt Spacers

SnapNrack Universal Skirt Spacer for 40mm, 38mm, 35mm, 32mm, and 30mm modules.

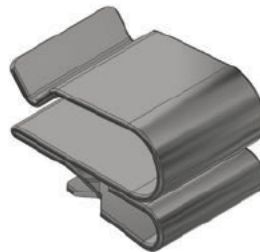

### Smart Clip

Module frame cable clip, holds two PV wires or Enphase IQ-Cables.

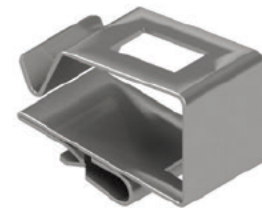

### Smart Clip XL

Module frame cable clip, holds six PV wires or four Enphase IQ-Cable.

## Grounding/MLPE Components



### Wire Saver

Designed to secure conductors that become loose and hang below the array, holds one conductor.

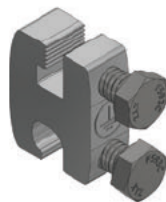

### Ground Lug

SnapNrack Ground Lug assembly used for attaching the Equipment Grounding Conductor on to one module or any TopSpeed™ Mount per array. 5

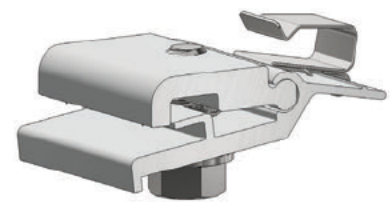

### MLPE Frame Attachment Kit

Attaches MLPEs (Module Level Performance Enhancers) and other related equipment to the module frame.

## Hardware Torque Specifications

The recommended torque to be applied to components for proper assembly and bonding are as follows:

Hardware Description	Torque Specification
All TopSpeed™ ½" bolts; System Leveling Bolt, TopSpeed™ Mount Clamping Bolt, Clamp Bolt	16 ft-lb
Ground Lug model 242-92202 to Module Frame or anywhere on the TopSpeed™ Mount, and Ground Lug model 242-92202 to Grounding Electrode Conductor (6-12 SOL)	8 ft-lb
MLPE Frame Attachment Kit, MLPE Rail Attachment Kit	10 ft-lb
SolarEdge Frame Mounted Microinverter Bracket to Module Frame	11 ft-lb
Enphase Frame Mounted Microinverter Bracket to Module Frame	13 ft-lb
Ground Lug model SGB-4 to module	75 in-lb
Ground Lug model SGB-4 to Grounding Electrode Conductor (4-14 SOL or STR)	35 in-lb
Ground Lug model GBL-4DBT to module	35 in-lb
Ground Lug model GBL-4DBT to Grounding Electrode Conductor (10-14 SOL or STR)	20 in-lb
Ground Lug model GBL-4DBT to Grounding Electrode Conductor (8 SOL or STR)	25 in-lb
Ground Lug model GBL-4DBT to Grounding Electrode Conductor (4-6 SOL or STR)	35 in-lb

# Pre-Installation Requirements

snaprack.com

## Site Survey

- Measure the roof surfaces and develop an accurate drawing, including any obstacles such as chimneys and roof vents.
- If plans for the roof structure are available, verify that the plans match the final structure.
- Identify any roof access or setback areas as required by the local AHJ.
- Identify any construction issues that may complicate the process of locating rafters from the roof surface.
- If you find structural problems such as termite damage or cracked rafters that may compromise the structure's integrity consult a structural engineer.

## Design Guidance

- PV Designers should account for the 0.75 inch spacing between rows and columns of modules when creating the layout.
- Determine site conditions for calculating the engineering values, confirm site conditions and code versions comply with local AHJ requirements.
- Reference site conditions and system specifications in TopSpeed™ Structural Engineering Report to determine the number of attachments per module side.
- Insert SnapNrack installation details into design plan set specific to the project requirements.
- Draw roof attachment locations on plan set layout based on TopSpeed™ Structural Engineering.

### Best Practice:

If environmental load conditions require three TopSpeed™ attachments per module side this is only required when modules share attachments.

- Identify homerun and Junction Box locations based on rooftop wiring requirements.
- Mark distance from array edge to identifiable roof feature in x and y axes.

### Safety Guidance

- Always wear appropriate OSHA approved safety equipment when at active construction site.
- Appropriate fall protection or prevention gear should be used. Always use extreme caution when near the edge of a roof.
- Use appropriate ladder safety equipment when accessing the roof from ground level.

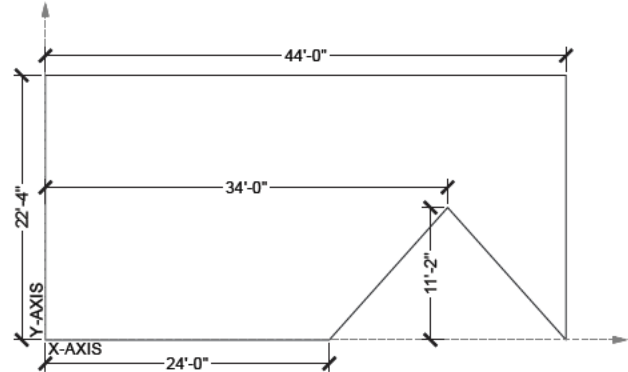

Image note: X-Axis described in this manual is cross-slope on the roof, Y-Axis is in line with the roof slope.

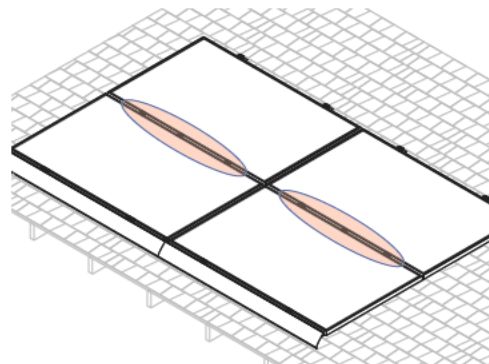
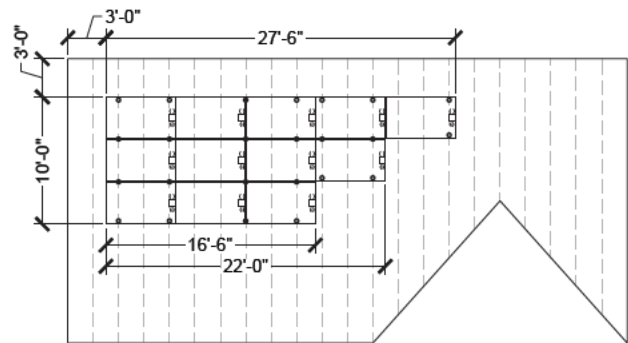

Image note: This four module array is installed in a high load configuration with three attachments per side where two modules share attachments. See highlighted area. As shown, three attachments are never required at the skirt or the top of the array.

### Safety Guidance Continued

- Safety equipment should be checked periodically for wear and quality issues.
- Always wear proper eye protection when required.



# TopSpeed™ Mount to Module Frame Installation

snapnrack.com

## Required Tools

● Socket Wrench/Impact Driver

● Torque Wrench

● 1/2" Socket

## Materials Included - TopSpeed™ System with SpeedSeal™ Technology

- 1) (1) SnapNrack TopSpeed™ Mount
- 2) (4) SnapNrack #14 Wood Screw with 1/2" Hex Head & sealing washer

### ⚙️ Best Practice:

Attach all TopSpeed™ mounts as the modules are being prepped with MLPEs on the ground. Attach Mounts before attaching MLPEs to simplify wire management.

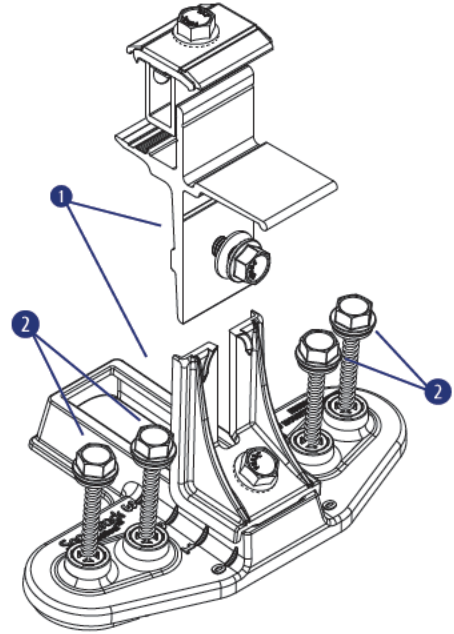

## INSTALLATION INSTRUCTIONS

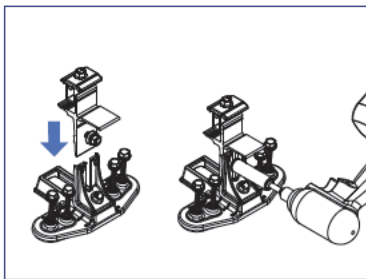

1) Assemble all TopSpeed™ Mounts required for the installation. Slide the clamp tower assembly into the angle bracket riser and tighten the leveling bolt to 16 ft-lbs.

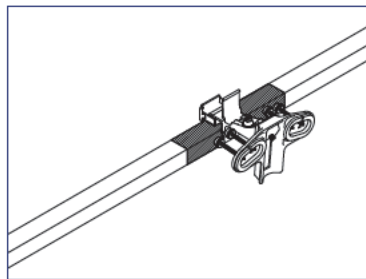

2) Position TopSpeed™ Mount clamp on the module frame within the module manufacturers required clamping zone.

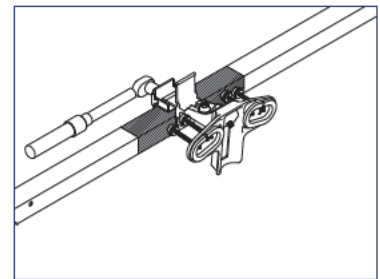

3) Tighten 1/2" clamping bolt to 16 ft-lb. Only two Mounts are required per module on one side.

### ⚙️ Install Note:

For high load conditions add a third attachment in the middle of the module frame.

# TopSpeed™ Universal Skirt Layout

snaprack.com

## Required Tools

- Roof Marking Crayon or Chalk
- Tape Measure

## LAYOUT INSTRUCTIONS

1) Use a tape measure to verify that all modules will fit properly on the roof surface.

2) On the roof draw the layout for the skirt installation including module gaps (recommended 0.75 inch gap), bottom corners, and locations of the two TopSpeed™ attachments per module that clamp to the skirt. Three attachments per module is never required at the skirt.

### Install Note:

If environmental load conditions require three TopSpeed™ attachments per module side this is only required when modules share attachments.

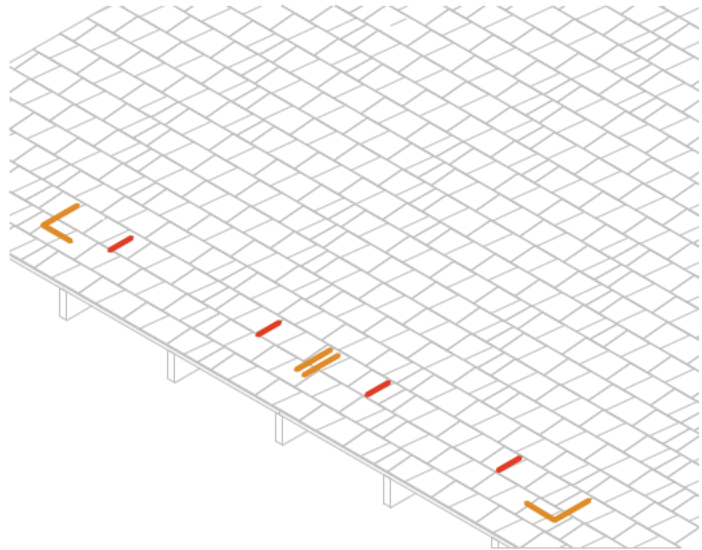

# TopSpeed™ Mount: Skirt Installation

snaprack.com

## Required Tools

- Socket Wrench/Impact Driver
- Torque Wrench
- 1/2" Socket
- Roofing sealant

## Materials Included - TopSpeed™ Mount with SpeedSeal™ Technology

- 1 (1) TopSpeed™ Mount
- 2 (1) TopSpeed™ Clamp
- 3 (1) Universal Skirt
- 4 (1) Universal Skirt Spacers
- 5 (1) *OPTIONAL* - Universal Link

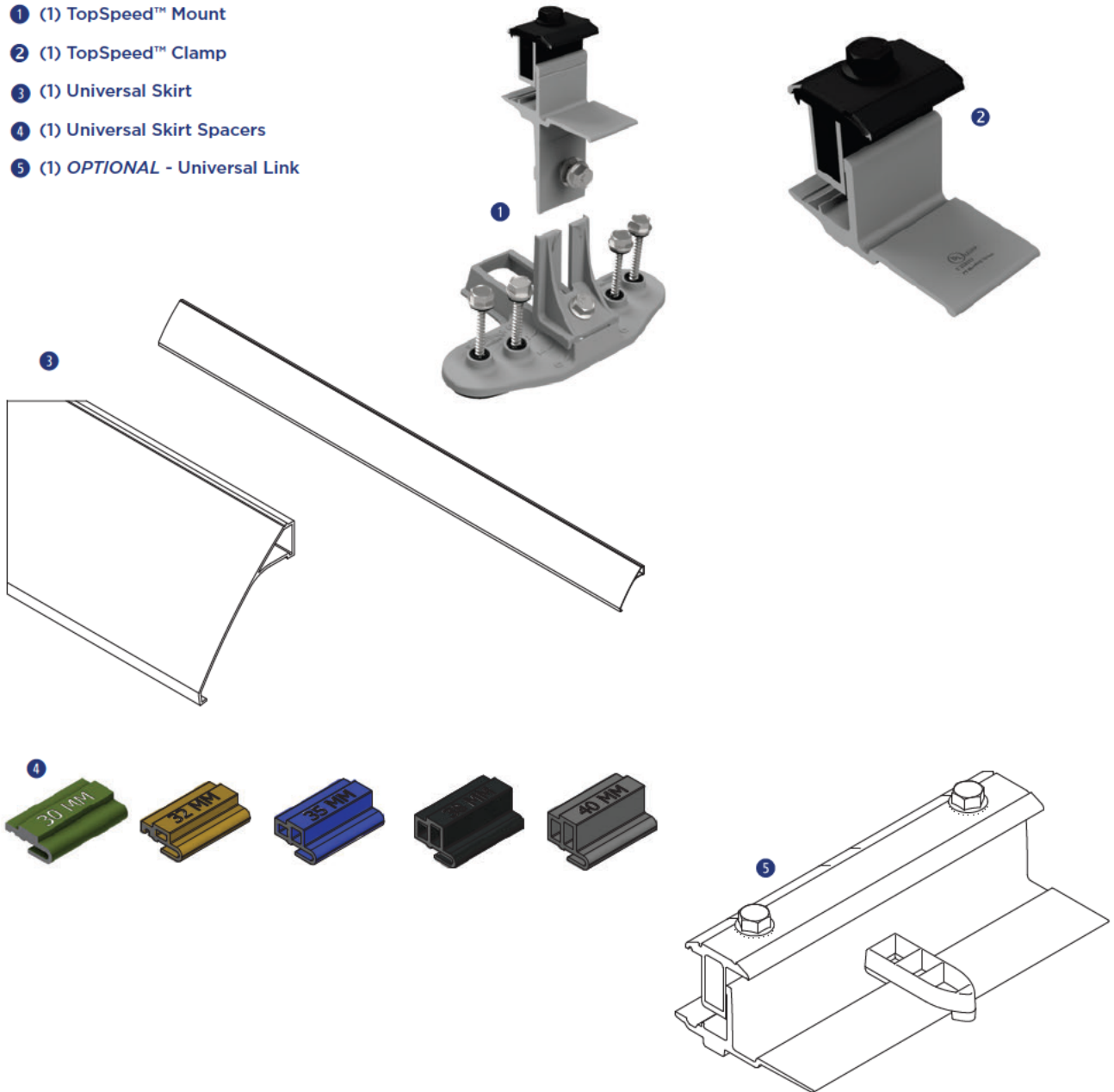



# TopSpeed™ Mount Skirt Installation

snaprack.com

## INSTALLATION INSTRUCTIONS

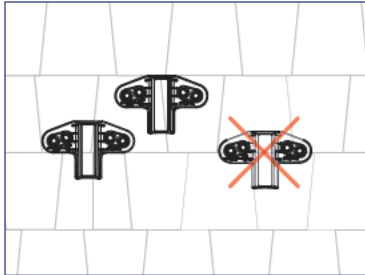

1) Install TopSpeed™ Mounts at locations drawn during the skirt layout. Mounts must be installed entirely on one course of composition.

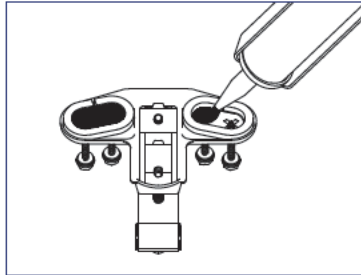

2) Fill both cavities on bottom of TopSpeed™ Mount created by SpeedSeal™ gasket with roof sealant to ensure a watertight seal.

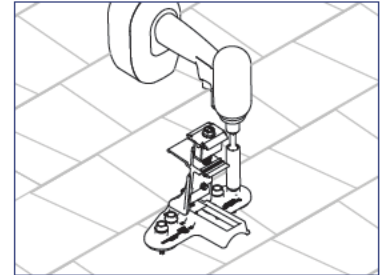

3) Attach TopSpeed™ Mount to roof using the (4) SnapNrack #14 Wood Screws with 1/2" hex head that are captured in the Mount.

### Install Note:

Roof sealant should be expelled from both vents of the TopSpeed™ Mount as it is installed to assure the proper amount of roof sealant has been applied. If sealant is not expelled from all four vents, remove TopSpeed™ Mount, add more sealant to the cavity, then reinstall.

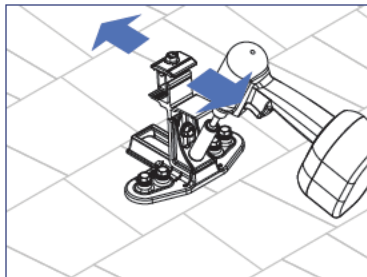

4) Loosen Course Adjustment bolt and adjust end Mounts up or down until aligned with bottom edge of array as marked on the roof, then tighten the Course Adjustment bolt.

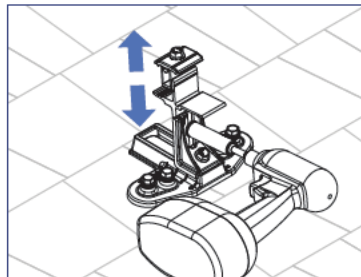

5) To set the TopSpeed™ Mount level loosen the Leveling bolt and move the clamp up or down, then tighten the Leveling bolt and torque to 16 ft-lb.

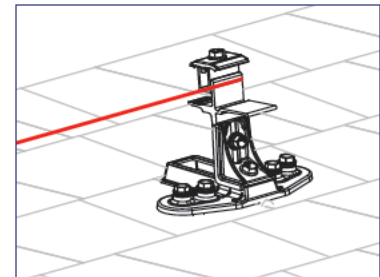

6) Pull string line tight from one corner mount to opposite corner mount to align and level all TopSpeed™ Mounts between the end mounts.

### Install Note:

Use the string line alignment feature on Mounts to level and align the Mounts.

# TopSpeed™ Mount Skirt Installation

snaprack.com

## INSTALLATION INSTRUCTIONS

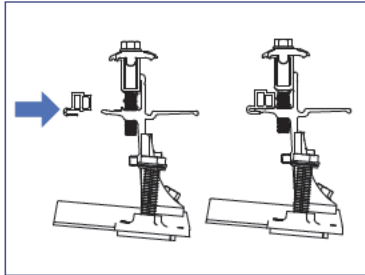

7) Universal Spacers will need to be added to Mounts and Clamps where Skirt will be installed.

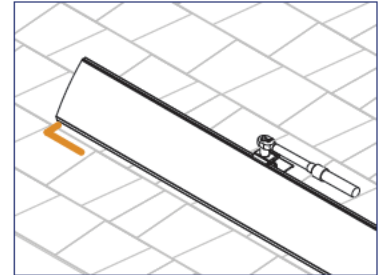
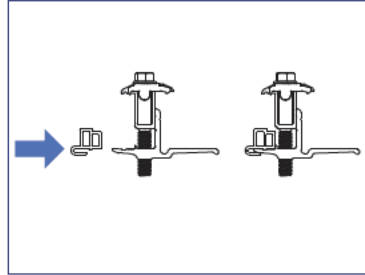

8) Install Universal Skirt by holding the skirt in Mount, sliding Skirt to align with array layout marks, and clamping skirt into mount.

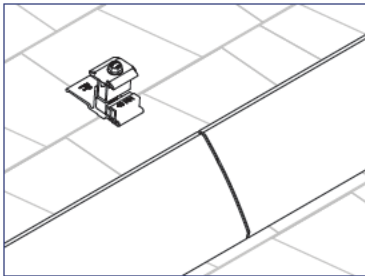

9) Use TopSpeed™ Clamps to connect multiple lengths of Array Skirt.

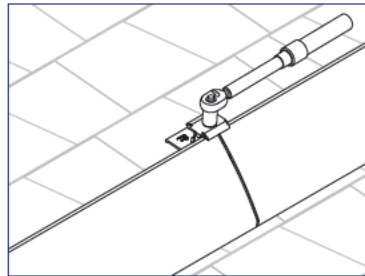

### Install Note:

Optionally use Universal Links to connect lengths of Array Skirt.

## Required Tools

- Socket Wrench
- Torque Wrench
- 1/2" Socket
- Electrician Tools

## Materials Included

### Smart Clips

- ① (1) Smart Clip [(2) PV Wire, (1) Enphase IQ Cable]
- ② (1) Smart Clip XL [(6) PV Wire, (4) Enphase IQ]
- ③ (1) Wire Saver [(1) PV Wire]

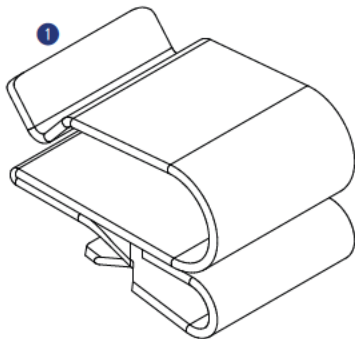

Smart Clip

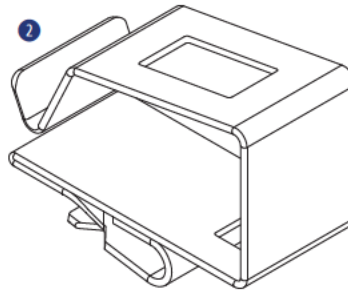

Smart Clip XL

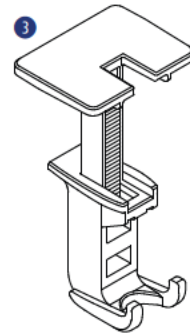

Wire Saver



## INSTALLATION INSTRUCTIONS - GROUND LUG

The SnapNrack Ground Lug to be used in accordance with the National Electric Code, ANSI/NFPA 70.

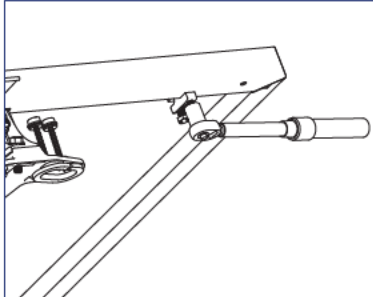

1) Ground Lug (242-92202) can be attached anywhere along the module frame or any TopSpeed™ Mount near the Junction Box. Torque module clamping bolt to 8 ft-lb.

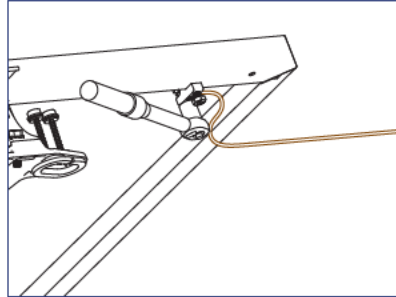

2) Run 10 - 6 AWG, solid, bare copper GEC into Ground Lug channel, torque wire clamping bolt to 8 ft-lb.

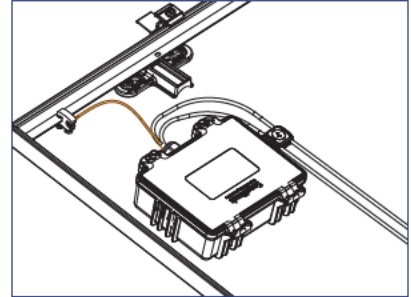

3) Run bare, solid EGC from Ground Lug R to Junction Box, bond bare EGC to stranded EGC in Junction Box. For details on installing the Junction Box reference the **Junction Box Installation Manual**.

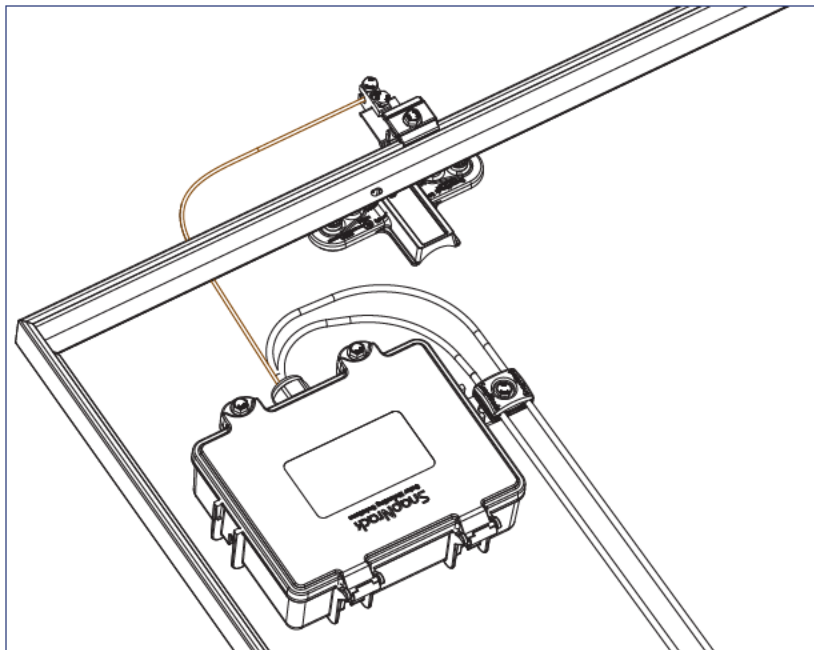

4) Optionally; Install Ground Lug on the Mount Landing Pad at the top of the array. Run bare copper between ground lug and Junction Box.

## INSTALLATION INSTRUCTIONS - SMART CLIPS

SmartClip and SmartClip XL should be used to route conductors in a neat and workmanlike manner away from all non-bonded components and support the conductors adequately to eliminate potential damage.

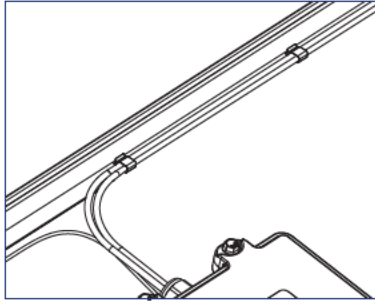

1) Use SnapNrack Smart Clip II to manage up two PV wires inside the module frame while prepping out the modules on the ground or installing modules on the roof.

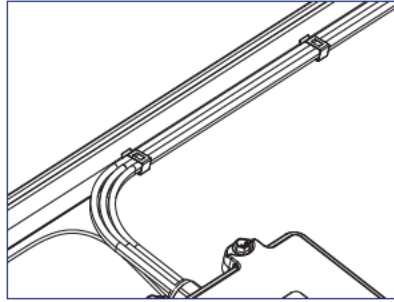

2) Use SnapNrack Smart Clip XL to manage larger bundles of PV wire; up to 6 PV wires per clip

# MLPE & RSD Installation

snaprack.com

## Required Tools

- Socket Wrench
- Torque Wrench
- 1/2" Socket

## Materials Included - MLPE Rail Attachment Kit

- 1 (1) SnapNrack MLPE Frame Attachment Top
- 2 (1) SnapNrack MLPE Frame Attachment Bottom
- 3 (1) 5/16"-18 X 3/4" Serrated Flange Bolt SS
- 4 (1) SnapNrack Smart Clip
- 5 (1) SnapNrack MLPE Frame Attachment Coil Spring SS

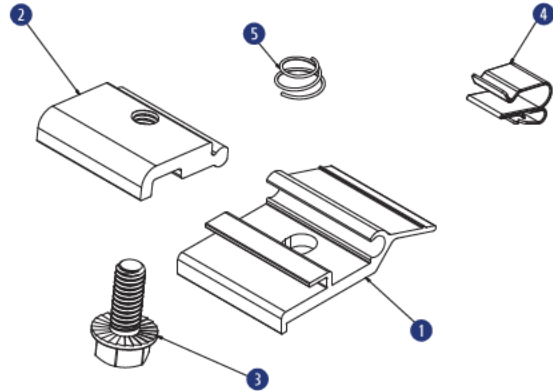
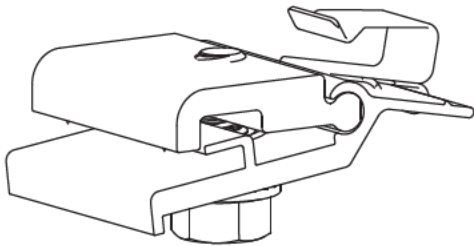

## Materials Included

### SolarEdge Frame Mount

- 1 (1) SolarEdge Optimizer w/ Frame-Mounted Module Add-On

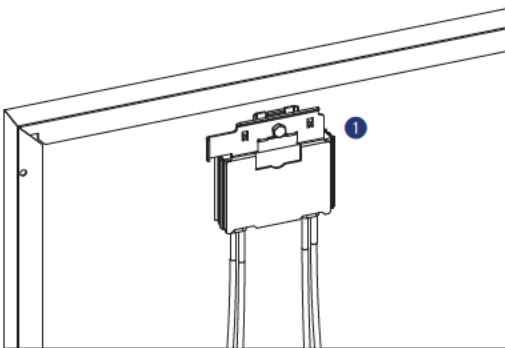

### Enphase Frame Mount

- 1 (1) Enphase Microinverter
- 2 (1) Enphase Frame Mount

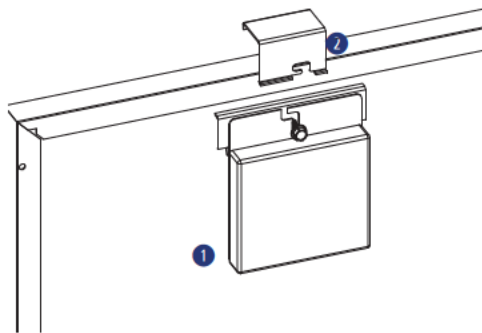



## INSTALLATION INSTRUCTIONS - SNAPNRACK MLPE FRAME ATTACHMENT KIT

SnapNrack MLPE Frame Attachment kit are used to attach module level performance enhancing devices, and other devices such as an SRD (rapid shutdown device), directly to module frames, and provide integrated grounding/bonding for Devices grounded through metal back plate. (Refer to the list of tested MLPE devices on page XX of this manual).

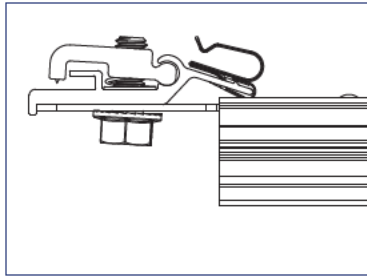

1) Slide the backplate channel of the MLPE device under the MLPE Frame Attachment Kit bolt. The MLPE mounting plate should rest against the MLPE mounting plate backstop on the MLPE Frame Attachment Kit.

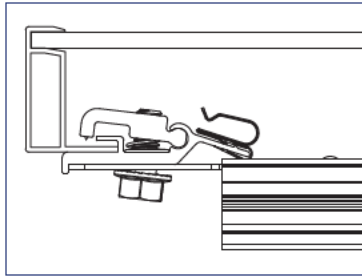

2) Position the MLPE Frame Attachment Kit on the module frame flange in a location that will not interfere with mounting system components. The module frame flange should rest against the module flange backstop on the MLPE Frame Attachment Kit.

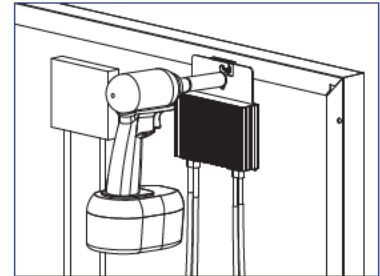

3) Tighten the mounting bolt on the MLPE Frame Attachment Kit to 12 lb-ft (144 lb-in).



### Install Note:

The MLPE Frame Attachment Kit bonds the following components:  
Module Frame, MLPE backplate and Smart Clip.



### Install Note:

Avoid blocking module frame drainage holes when installing the MLPE Frame Attachment Kit.

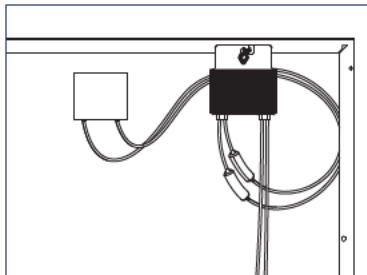

4) Connect the module leads to the input connectors on the MLPE device and manage conductors with the integrated Smart Clip.

## INSTALLATION INSTRUCTIONS - SOLAREEDGE FRAME MOUNT

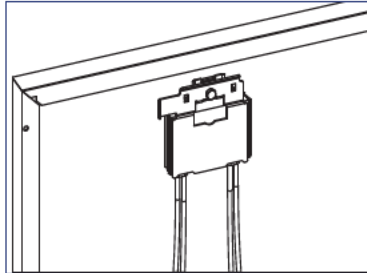

1) Locate the SolarEdge optimizer with Frame-Mounted Module Add-On at a location on the module frame that will not interfere with the TopSpeed™ Mounts.

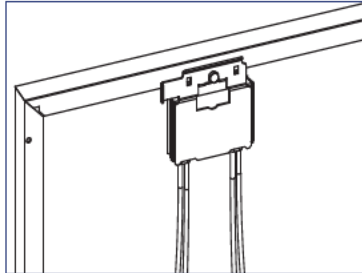

2) Install the optimizer mounting plate onto the module frame and tighten hardware to 11 ft-lbs.

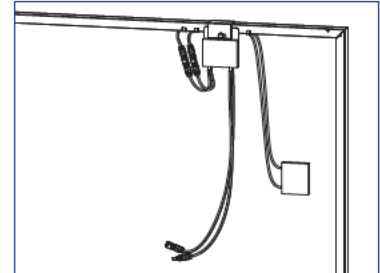

3) Connect the module leads to the input connectors on the optimizer and manage conductors with SnapNrack Smart Clips.

**Install Note:**  
If module is mounted in portrait, install MLPE on long side, short side for landscape.

## INSTALLATION INSTRUCTIONS - ENPHASE FRAME MOUNT

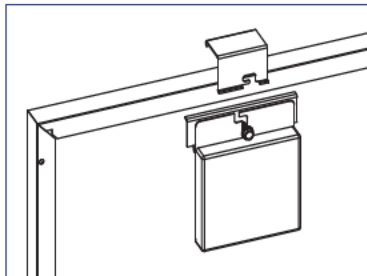

1) Locate the Enphase Frame Mount bracket clamp at a location on the module frame that will not interfere with the TopSpeed™ Mounts.

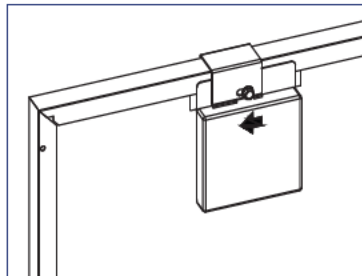

2) Slide the microinverter unit onto the bracket clamp, then move it slightly to the left.

**Install Note:**  
The microinverter mounting flange should be on the outside of the module frame.

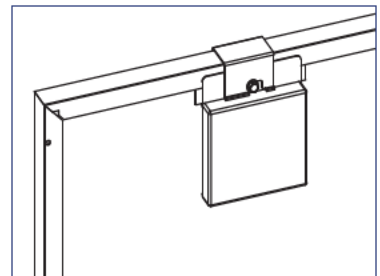

3) Tighten the hardware to 13 ft-lbs.

4) Connect module leads to microinverter DC connectors.

**Install Note:**  
Refer to the Enphase Frame Mount installation guide for additional instructions.

# Module Installation

snaprack.com

## Required Tools

- Socket Wrench
- Torque Wrench
- 1/2" Socket
- Roofing Sealant

## Materials Included

- ① SnapNrack TopSpeed™ Mount
- ② SnapNrack TopSpeed™ Clamp

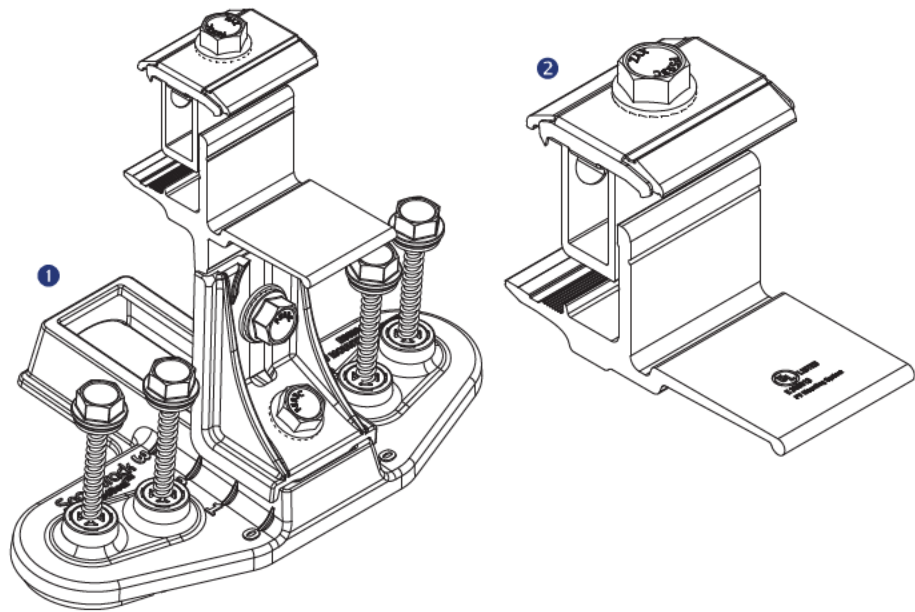

## Other Materials Required

- ② SnapNrack Smart Clip (2-5 per module)  
*See Wire Management section for details*
- ③ SnapNrack Smart Clip XL (10-20 per array)  
*See Wire Management section for details*

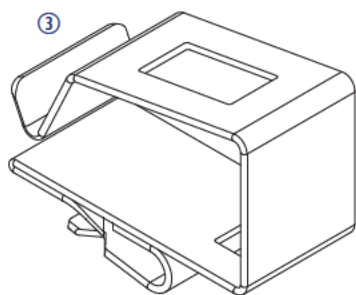
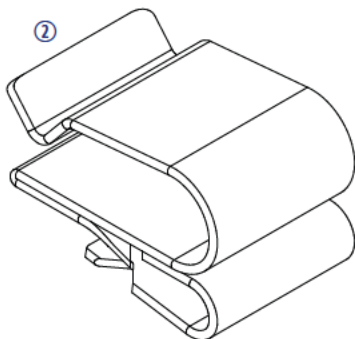

## INSTALLATION INSTRUCTIONS - BOTTOM ROW

### Recommended Best Practice:

**Attach all TopSpeed™ mounts as the modules are being prepped with MLPEs on the ground. Attach Mounts before attaching MLPEs to simplify wire management.**

### Install Note:

It is recommended that module leads and connectors are prepared for installation using SnapNrack Smart Clips before being brought to the rooftop.

- With no MLPE, secure module leads to module frame to allow access to connectors while modules are installed
- Secure MLPE device to module frame with SnapNrack MLPE Frame Attachment Kit and connect module leads to MLPE, and manage leads by positioning connectors to allow access during installation

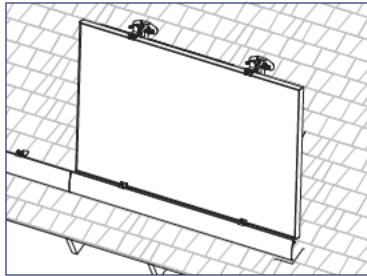

1) Rest downslope edge of module on the Mounts and/or Clamps position module so side edge is flush with marked edge of array layout or Skirt.

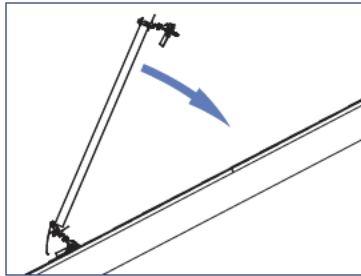

2) Lower upslope edge of module while simultaneously applying slight pressure to seat module into Mounts and/or Clamps.

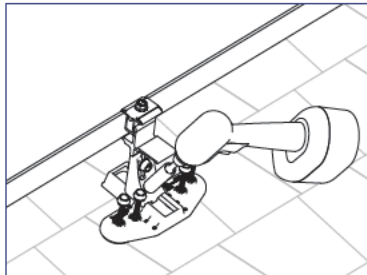

3) When module is level with roof verify the SpeedSeal™ portion of the TopSpeed™ Mounts are positioned entirely on one course of composition. If required listen the 1/2" nut and adjust the base as needed then tighten the bolt.

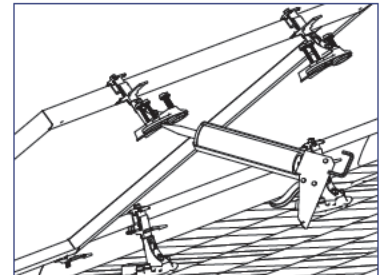
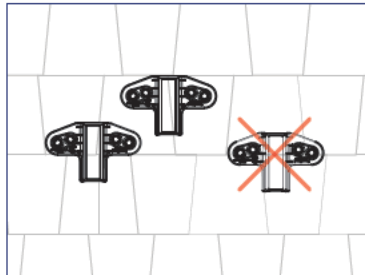

4) Lift the upslope edge of the module and fill the SpeedSeal™ reservoir with roofing sealant.

### Install Note:

Roof sealant should be expelled from both vents of the TopSpeed™ Mount as it is installed to assure the proper amount of roof sealant has been applied. If sealant is not expelled from all four vents, remove TopSpeed™ Mount, add more sealant to the cavity, then reinstall.



## INSTALLATION INSTRUCTIONS - BOTTOM ROW

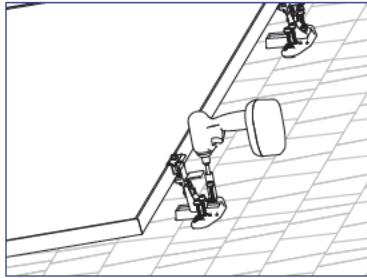

5) Lower the module to the roof and drive the (4) pre installed Snaprack #14 Wood Screws with 1/2" hex head into the roof sheathing.

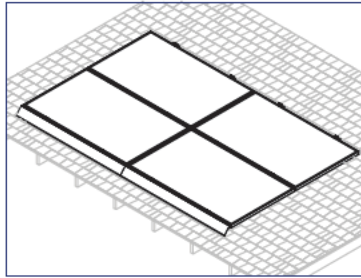

6) Repeat steps 1 through 5 for additional modules in the array.

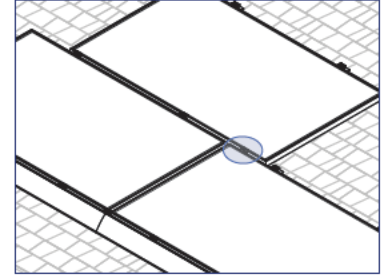

7) For staggered arrays and arrays with mixed orientation, use the TopSpeed™ Clamp as needed to support the modules.

### Install Note:

Roof sealant should be expelled from both vents of the TopSpeed™ Mount as it is installed to assure the proper amount of roof sealant has been applied. If sealant is not expelled from both vents, remove TopSpeed™ Mount, add more sealant to the cavity, then reinstall.

When installing a TopSpeed™ Clamp for support of an over cantilevered module, the clamp shall be installed 2-6" from the edge of the upslope (cantilevered) module.

## GROUND PATH DETAILS

All TopSpeed™ components in the fault current ground path have been Certified to be used multiple times for grounding/bonding. The UL 2703 Listing does not specify a maximum number of uses for the Mount, Link, or Ground Lug. Review the requirements of the National Electrical Code (NEC) Article 250 to select the appropriate Equipment Grounding Conductor size based on the short-circuit current of the PV system.

When using Ground Lug R the following components are part of the fault current ground path:

- SnapNrack, TopSpeed™ Mount
- SnapNrack, TopSpeed™ Clamp

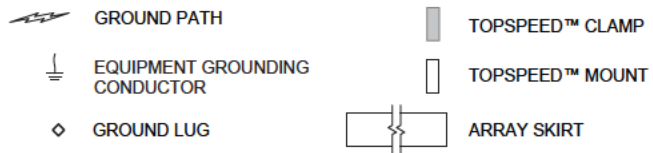
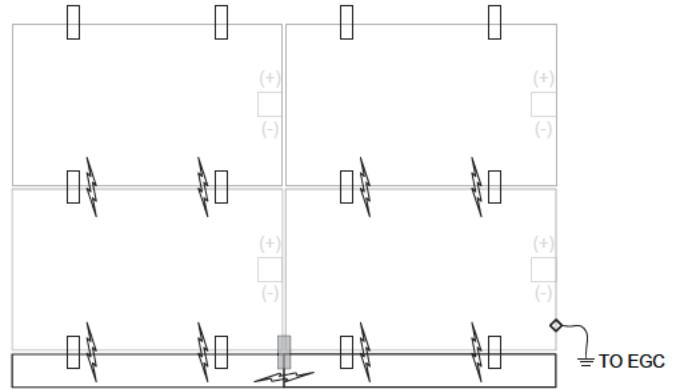

## GROUNDING METHOD DETAILS

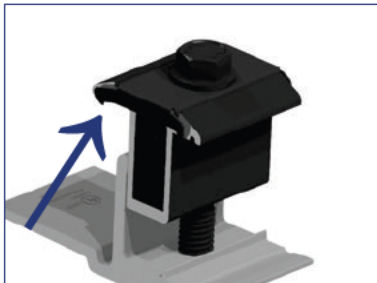

1) Row to row module bonding provided by bonding clips in Mount assembly and Clamp assembly.

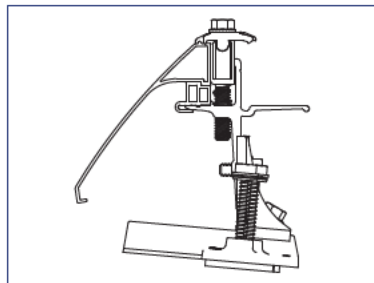

2) Column to column bonding provided by Universal Skirt and bonding clips in the Clamp assembly and/or the RL Universal Link assembly.  
Module heights evaluated for bonding with Link Bonding Clamps: 40mm, 38mm, 35mm, 32mm, 30mm

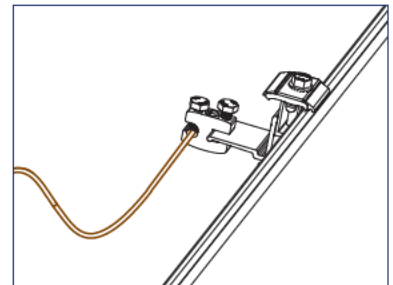
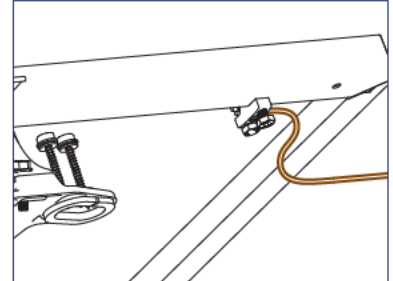

3) Each continuous array is connected to Equipment Grounding Conductor through Ground Lug (242-92202) installed on one module per array.

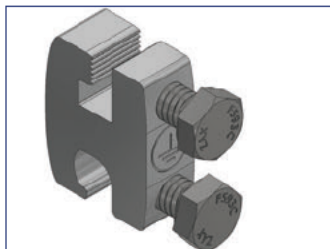

## GROUNDING MARKING DETAILS

The Ground Lug is marked with the ground symbol.

Optionally; Install Ground Lug on the Mount Landing Pad at the top of the array.

# Maintaining the Grounding Bonding When Removing a Module

snaprack.com

## INSTRUCTION FOR MAINTAINING THE GROUNDING BONDING WHEN REMOVING A MODULE FOR SERVICING

**CAUTION:** Module removal may disrupt the bonding path and could introduce the risk of electric shock. Additional steps may be required to maintain the bonding path. Modules should only be removed by qualified persons in compliance with the instructions in this manual.

Module removal is not presented as a frequently expected occurrence and will not be required as part of routine maintenance.

Scenarios that could result in a disruption of the bonding path are described, for example irregularly-shaped arrays, arrays consisting of individual rows, and any other scenario where module removal could disrupt the bonding path. In most cases, the removal of a module for servicing will not disturb or break grounding continuity. If a module is to be removed that will break continuity, these are the steps that must be taken to maintain a continuously bonded SnapNrack TopSpeed™ System.

### Required Tools

● Socket Wrench

● Torque Wrench

● 1/2" Socket

● 7/16" Socket

### Required Materials

- 1 #10 Or Larger Bare Copper Conductor
- 2 SnapNrack Ground Lug part no. 242-92202
- 3 IlSCO Part No. SGB-4
- 4 DnoRaxx Dynobond™

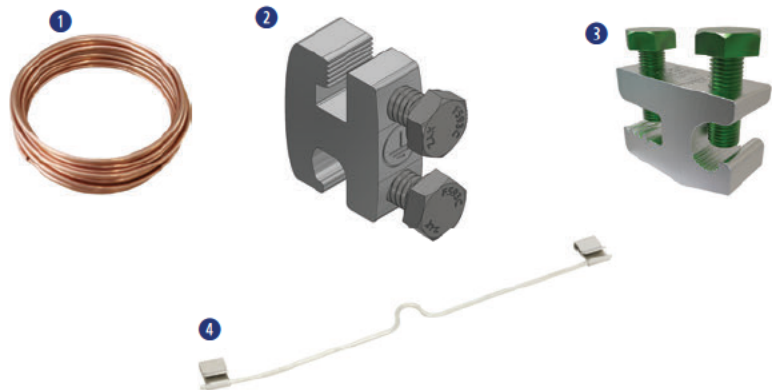

# Maintaining the Grounding Bonding When Removing a Module

## JUMPER ASSEMBLY INSTRUCTION & INSTALLATION

**CAUTION:** Do Not Remove the Module until the Jumper is installed

1) Identify the existing ground path at the location of module removal and choose an appropriate length of #10 bare copper to bridge the soon to be broken ground path.

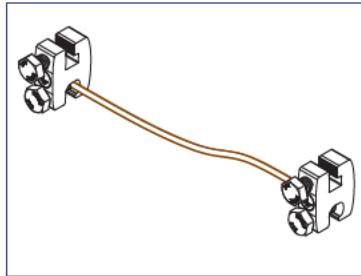

*Example of assembled bonding jumper using (2) SnapNrack Ground Lugs*

- 2) Attach one ground lug to each end of #10 bare copper wire. See recommended options below:
1. (2) SnapNrack Ground Lug part no. 242-922022
  2. (2) IlSCO part no. SGB-4
  3. (1) DroRaxx DynoBond™

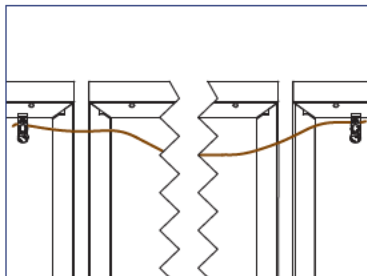

3) Before the module is removed, attach the assembled bonding jumper. Depending on where the module will be removed and choice of ground lug, jumper attachment locations will vary.

- SnapNrack Ground Lug part no. 242-92202 or IlSCO SGB-4 lugs can be attached to module frames or anywhere on the TopSpeed™ Mount.
- DynoRaxx DynoBond™ is approved and appropriate when a short bonding jumper is needed from module to module.

4) Service the array. With the bonding jumper installed, it is now safe to remove the module for service or maintenance.

5) After Servicing the array reinstall the module and original ground path. Only then Remove the bonding jumper.

**Caution:** Do not remove the bonding jumper until original ground path is established.



# Appendix A

## APPROVED MODULE & MLPE INFORMATION

SnapNrack TopSpeed™ System has been tested with the following UL Listed module series: The SnapNrack TopSpeed™ System employs top-down clamps and links which have been evaluated for frame-to-system bonding, at specific mounting torques and with the specific module series listed below. All wattage values are covered.

Module manufacturer approval letters can be found at [www.snaprack.com](http://www.snaprack.com).

Manufacturer	Model	
Aptos Solar	DNA-120-MF23-XXX	DNA-120-BF26-XXXW
	DNA-120-BF23-XXX	DNA-144-BF26-XXXW
	DNA-144-MF23-XXX	DNA-108-BF10-xxxW
	DNA-144-BF23-XXX	DNA-120-BF10-xxxW
	DNA-120-MF26-XXXW	DNA-108-MF10-xxxW
	DNA-144-MF26-XXXW	
Canadian Solar	CS6K-XXX-M	CS1H-XXX-MS
	CS6K-XXX-M-SD	CS1H-XXX-MS-AB
	CS6K-XXX-P	CS3W-XXX-P
	CS6K-XXX-P-SD	CS3N-XXX-MS
	CS6K-XXX-MS	CS1Y-XXX-MS
	CS3K-XXX-P	CS3W-MB-AG
	CS3K-XXX-MS	CS3Y-MB-AG
	CS3U-XXX-MS	CS6W-XXXMB-AG
	CS3U-XXX-P	CS6R-XXXMS-HL
	CS1K-XXX-MS	CS3W-XXX-MS
CertainTeed	CTXXXHC11-06	
Chint Solar	CHSM6612M-XXX	CHSM72M-HC-XXX* (Astro 4)
	CHSM6612M(BL)-XXX	CHSM72M-HC-XXX* (Astro 5)
	CHSM6612M/HV-XXX	
Dehui Solar	DH-M760B-XXXW	DH-M760F-XXXW
	DH-M760W-XXXW	DH-M772F-XXXW
	DH-M772W-XXXW	
Freedom Forever	FF-MP-BBB-xxx	
Hanwha Q Cells	Q.PEAK DUO-G5-XXX	Q.PEAK DUO XL-G10.3/BFG-XXX
	Q.PEAK DUO-BLK-G5-XXX	Q.PEAK DUO G10-XXX
	Q.PLUS DUO-G5-XXX	Q.PEAK DUO BLK G10-XXX
	Q.PEAK DUO-G7-XXX	Q.PEAK DUO G10+-XXX
	Q.PEAK DUO-BLK-G7-XXX	Q.PEAK DUO BLK G10+-XXX
	Q.PEAK DUO-G7.2-XXX	Q.PEAK DUO XL-G10.3-XXX
	Q.PEAK DUO-G6+-XXX	Q.PEAK DUO XL-G10.c-XXX
	Q.PEAK DUO-BLK-G6+-XXX	Q.PEAK DUO XL-G10.d-XXX
	Q.PEAK DUO-G6-XXX	Q.PEAK DUO L-G8.3/BFG-XXX
	Q.PEAK DUO-BLK-G6-XXX	Q.PEAK DUO L-G8.3/BGT-XXX
	Q.PEAK DUO-G8+-XXX	Q.PEAK DUO ML-G10-XXX
	Q.PEAK DUO-BLK-G8+-XXX	Q.PEAK DUO BLK ML-G10+-XXX

# Appendix A

Manufacturer	Model	
Hanwha Q Cells	Q.PEAK DUO-G8-XXX	Q.PEAK DUO ML-G10+-XXX
	Q.PEAK DUO-BLK-G8-XXX	Q.PEAK DUO BLK ML-G10-XXX
	Q.PEAK DUO BLK-G6+/AC-XXX	Q.PEAK DUO ML-G10.a+-XXX
	Q.PEAK DUO-ML-G9-XXX	Q.PEAK DUO BLK ML-G10.a+-XXX
	Q.PEAK DUO-BLK-ML-G9-XXX	Q.PEAK DUO ML-G10.a-XXX
	Q.PEAK DUO-BLK-G9-XXX	Q.PEAK DUO BLK ML-G10.a-XXX
	Q.PEAK DUO-BLK-ML-G9+-XXX	Q.PEAK DUO BLK G10+/AC XXX
	Q.PEAK DUO-ML-G9+-XXX	Q.PEAK DUO BLK G10+/HL XXX
	Q.PEAK DUO-BLK-ML-G9+-XXX	Q.PEAK DUO XL-G11.3 XXX
	Q.PEAK DUO XL-G9.2-XXX	Q.PEAK DUO XL-G11.3 BFG XXX
	Q.PEAK DUO XL-G9.3-XXX	Q.TRON-G1+ XXX
	Q.PEAK DUO XL-G9.3/BFG-XXX	Q.TRON BLK-G1+ XXX
	Q.PEAK DUO XL-G10.2-XXX	
HT-SAAE	HT60-166M-XXX	HT60-182M-XXX
Heliene	60M-XXX	72M-XXX
	60P-XXX	72P-XXX
"Hyundai (All may be followed by "BK")"	HiA-SXXXMS	HiS-SXXXXYI
	HiS-SXXXXY	HiS-SXXXXYH(BK)
Hyperion/Runergy	HY-DH108P8-XXX(Y)	
JA Solar	JAM60S09-XXX/PR	JAM72S10-XXX/PR
	JAM60S10-XXX/MR	JAM72S12-XXX/PR
	JAM60S10-XXX/PR	JAM60S17-XXX/MR
	JAM60S12-XXX/PR	JAM54S30-XXX/MR
	JAM72S09-XXX/PR	JAM54S31-XXX/MR
	JAM72S10-XXX/MR	JAM72D30-XXX/MB
Jinko Solar	JKMXXXM-60	JKMXXXP-72-V
	JKMXXXM-60L	JKMXXPP-72
	JKMXXXM-60HL	JKMXXPP-72-V
	JKMXXXM-60HBL	JKMSXXXP-72
	JKMXXXP-60	JKMXXXM-72HL-V
	JKMXXXP-60-J4	JKMXXXM-72HL-TV
	JKMXXXP-60-V	JKMXXXM-72HBL
	JKMXXXP-60B-J4	JKMXXXM-6TL3-B
	JKMXXXP-60	JKMXXXM-6RL3-B
	JKMXXPP-60-V	JKMXXXM-7RL3-V
	JKMXXXM-72	JKMXXXM-7RL3-TV
	JKMXXXM-72L-V	JKMXXXM-72HL4-V
	JKMXXXP-72	JKMXXXM-72HL4-TV
LG	LGXXN1C-A5	LGXXA1C-V5
	LGXXN1K-A5	LGXXM1C-L5
	LGXXQ1C-A5	LGXXM1K-L5
	LGXXQ1K-A5	LGXXN1C-N5
	LGXXS1C-A5	LGXXN1K-L5
	LGXXN2C-B3	LGXXN1K-A6
	LGXXN2W-B3	LGXXN1C-A6

# Appendix A

Manufacturer	Model	
LG	LGXXN1C-G4	LGXXN1W-A6
	LGXXN1K-G4	LGXXQ1C-A6
	LGXXS1C-G4	LGXXQ1K-A6
	LGXXN2C-G4	LGXXM1K-A6
	LGXXN2K-G4	LGXXM1C-A6
	LGXXN2W-G4	LGXXA1C-A6
	LGXXS2C-G4	LGXXQAC-A6
	LGXXS2W-G4	LGXXQAK-A6
	LGXXN1C-V5	LGXXN1K-B6
	LGXXN1W-V5	LGXXN2W-E6
	LGXXN2T-V5	LGXXN2T-E6
	LGXXN2T-J5	LGXXN1K-E6
	LGXXN1T-V5	LGXXN3K-V6
Longi	LR6-60-XXXM	LR4-60HPB-XXXM
	LR6-60BK-XXXM	LR4-60HIB-XXXM
	LR6-60HV-XXXM	LR4-60HPH-XXXM
	LR6-60PB-XXXM	LR4-60HIH-XXXM
	LR6-60PE-XXXM	LR6-60HIH-XXXM
	LR6-60PH-XXXM	LR6-60HIB-XXXM
	LR6-60HPB-XXXM	LR4-72HPH-XXXM
	LR6-60HPH-XXXM	
Meyer Burger	Meyer Burger Black*	Meyer Burger White*
mSolar	TX16-XXX120BB	
Mission Solar	MSEXXS05T	MSEXXSQ4S
	MSEXXS05K	MSEXXS8K
	MSEXXSQ5T	MSEXXS8T
	MSEXXSQ5K	MSEXXS9S
	MSEXXM4J	MSE60AXXX
	MSEXXM6J	MSEXXS5K
	MSEXXS06W	MSEXXS5T
	MSEXXS04J	MSEXXS6S
	MSEXXS06J	MSEXXS6W
	MSEXXSQ6S	MSEXXS5R
Next Energy Alliance	USNEA-XXXM3-60	USNEA-XXXM3-72
	USNEA-XXXM3B-60	USNEA-XXXM3B-72
Panasonic	VBHXXXKA03	VBHXXXRA18N
	VBHXXXKA04	VBHXXXRA03K
	VBHXXXSA17	EVPVXX(K)
	VBHXXXSA18	EVPVXXH
	VBH325SA17E	EVPVXXPK
Phono Solar	PSXXM-20/U	PSxxxM8GF-18/VH
	PSXXMH-20/U	PSxxxM8GFH-18/VH
	PSxxxM8GF-24/TH	PSxxxM6-24/TH
	PSxxxM8GFH-24/TH	

# Appendix A

Manufacturer	Model	
REC (All may be followed by "BLK" or "BLACK")	RECXXTP2	RECXXTP2SM 72 BLK2
	RECXXTP2-BLK	RECXXXAA
	RECXXNP	RECXXTP3M
	RECXXTP2M	RECXXTP4
	RECXXTP2M 72	RECXXXAA Pure
	RECXXTP2M 72 BLK	RECXXXAA Pure-R
	RECXXTP2M 72 BLK2	RECXXNP2
	RECXXTP2SM 72	RECXXNP3
	RECXXTP2SM 72 BLK	
SEG Solar	SEG-400-BMB-HV	SEG-xxx-BMD-HV
	SEG-400-BMB-TB	SEG-xxx-BMD-TB
Silfab	SLAXX-M	SILXXXNT
	SLAXX-P	SILXXXHL
	SSAXX-M	SILXXXBK
	SSAXX-P	SILXXXNX
	SILXXXBL	SILXXXNU
	SILXXXML	SILXXXHC
	SILXXXNL	SILXXXHN
	SLGXX-M	SILXXXBG
	SLGXX-P	SIL-xxxHC+
	SSGXX-M	SIL-xxxHM
	SSGXX-P	
Solaria	Solaria PowerXT-XXXR-PX	Solaria PowerXT-XXXR-PM
	Solaria PowerXT-XXXR-BX	Solaria PowerXT-XXXR-PM-AC
	Solaria PowerXT-XXXR-AC	
Sunpower	SPR-AXXX-G-AC	SPR-MXXX-H-AC
	SPR-AXXX	SPR-MXXX
	SPR-AXXX-BLK-G-AC	SPR-MXXX-BLK-H-AC
	SPR-AXXX-BLK	SPR-MXXX-BLK
SunSpark	SST-XXXM3-60	SST-XXXM3-72
	SST-XXXM3B-60	SST-XXXM3B-72
Talesun	TP660M-XXX	TP672M-XXX
	TP660P-XXX	TP672P-XXX
Trina	TSM-XXXDD05(II)	TSMXXXDD05H.05(II)
	TSM-XXXDD05A.05(II)	TSM-XXXDD06M.05(II)
	TSM-XXXDD05A.08(II)	TSM-XXXDE15H(II)
	TSM-XXXDD05A.082(II)	TSM-XXXDE15M(II)
	TSM-XXXPA05	TSMXXXDE06X.05(II)
	TSM-XXXPA05.05	TSMXXXDE09.05
	TSM-XXXPA05.08	TSM-XXXDE15V(II)
	TSM-XXXPD05	TSM-XXXDEG15VC.20(II)
	TSM-XXXPD05.002	TSM-XXXDEG18MC.20(II)
	TSM-XXXPD05.05	TSM-XXXDEG19C.20



# Appendix A

Manufacturer	Model	
Trina	TSM-XXXPD05.05S	TSM-XXXDEG21C.20
	TSM-XXXPD05.08	TSM-XXXDE09C.05
	TSM-XXXPD05.082	TSM-XXXDE09C.07
	TSM-XXXPD05.08D	TSM-xxxNE09RC.05
	TSM-XXXPD05.08S	
Vikram Solar	SOMERA VSMHBB.60.XXX.05	PREXOS VSMDHT.60.XXX.05
	SOMERA VSMH.72.XXX.05	PREXOS VSMDHT.72.XXX.05
VSUN	VSUNXXX-144BMH-DG	VSUNXXX-108BMH
	VSUNXXX-120BMH	
ZNShine	ZXM6-60-XXX/M	ZXM6-NH144-XXXM
	ZXM6-NH120-XXXM	ZXM7-SH108-XXXM

# Appendix A

SnapNrack TopSpeed™ has been tested with the following Module Level Power Electronic (MLPE) devices:

SnapNrack TopSpeed™ mounting systems has been tested with the following UL/NRTL Listed Module Level Power Electronic (MLPE) Devices. The back plates of the MLPEs have been evaluated for bonding to TopSpeed™ through the SnapNrack MLPE Frame Attachment Kit, model 242-02151.

MLPE Manufacturer	Model	
AP Smart	RSD-S-PLC	
Celestica International	DG-006-F001201x	DG-006-F001401x
Delta Electronics	GPI00010105	
Enphase	C250	IQ7PLUS-72-2-US
	M215	IQ7PLUS-72-B-US
	M250	IQ8-60
	IQ6-60-2-US	IQ8PLUS-72
	IQ6PLUS-72-2-US	IQ8A-72
	IQ7-60-2-US	IQ8H-208-72
	IQ7-60-B-US	IQ8H-240-72
Generec	S2502	
Ginlong Technologies	Solis-RSD-1G	
	Solis-MLRSD-R1-1G	Solis-MLRSD-R2-1G
SolarEdge	P300-5NC4ARS	P320-5NC4ARS
	P370-5NC4AFS	P400-5NC4AFS
	P320	P340
	P370	P400
	P401	P405
	P485	P505
	P730	P800p
	P850	P860
	P950	P1100
	P1101	S440
	S500	
SMA	RSB-2S-US-10	
Tigo	TS4-R-F	TS4-R-M
	TS4-R-O	TS4-R-S
	TS4-R-M-DUO	TS4-R-O-DUO
	TS4-R-S-DUO	TS4-A-F
	TS4-A-2F	TS4-A-O
	TS4-A-S	