

Use Permits for Public Spaces Design Processes

Nick Rogers – Principal Planner, CPHD

Irena Lazic – Long Range Park Planning Section Supervisor, DPR

Walter Gonzalez – Associate Planner, DPR



Purpose

- Enable the County Board to consider case-by-case modifications of Arlington’s zoning laws to allow:
 - More flexibility for where amenities are located in public spaces
 - Avoidance of environmentally sensitive areas
 - Avoidance of additional parking when unnecessary or when alternatives are available
- Mechanism – County Board use permit process
- 2019 [Public Spaces Master Plan](#)'s [Action Plan](#) recommends the County review and consider updating the zoning regulations related to parks and public spaces
- The PSMP recommends studying setbacks, athletic field, and other lighting, parking and parking options, dog parks and dog runs, signage, height, water features, fencing and temporary use of public and private property as public space.



An element of
Arlington County's
Comprehensive Plan



PSMP & Zoning

PSMP Recommendation:

- 1.5.10. Review and consider updating the County’s zoning regulations related to parks and public spaces in “S-3A” and “PS” districts, and other County codes as needed, related to setbacks, athletic field and other lighting, parking and parking options, dog parks and dog runs, signage, height, water features, fencing and temporary use of public and private property as public space.

Progress Completed to Date:

Phase 1 completed in March 2023, focused on:

- Stormwater management
- Placement
- Setbacks
- Maximum height for fence & walls

Current Step:

- **Phase 2**, schedule for Fall/Winter 2023:
 - County Board authority to approve increased height, reduced setbacks, and reduced parking amounts on a case-by-case basis (Use Permit req.)
- **Phase 3**, targeted timing to be commenced in 2024 :
 - Comprehensive study, with possible support from consultant team
 - Identify best practices for flexible zoning standards for public spaces
 - Topics to evaluate include definitions/terms, new standards for height/setbacks, sign regulations, and by-right parks outside S-3A district

Public Involvement with Public Space Planning

- Park projects follow the County's Six-Step Public Engagement Guide
- Typically consist of 2-3 engagements or more depending on complexity
- Include a variety of engagement tools
- **1st Engagement** – Visioning work with community to solicit feedback on proposed amenities or uses
- **2nd Engagement** – Concept(s) developed and shared back out to the public for feedback
 - Present to appropriate Commissions
- **3rd Engagement** – Present final concept

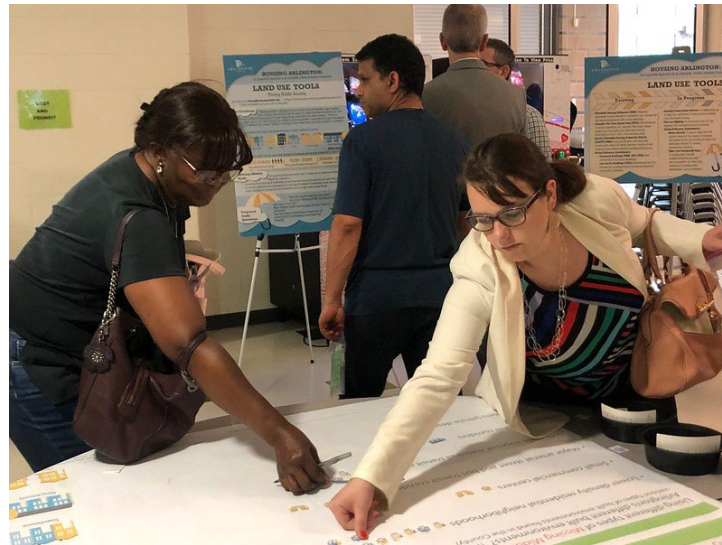

Integration of Use Permit into DPR Engagement

Sample Timeline

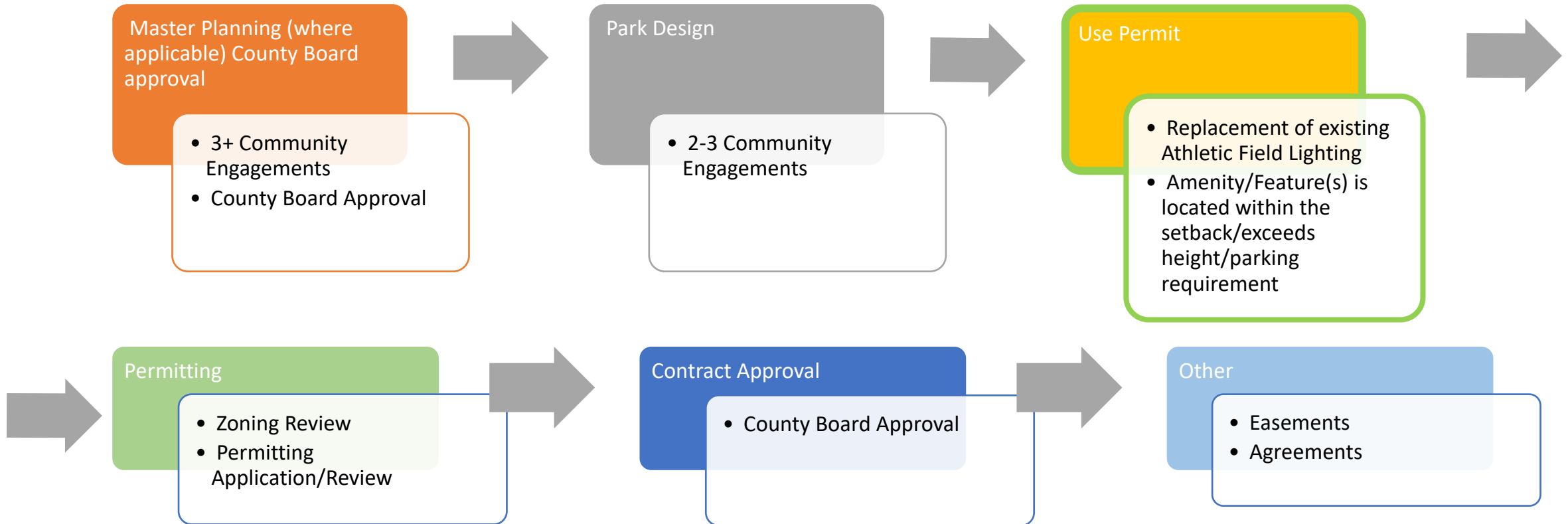

- Use permit review would typically occur near or at the end of design
- Use permit review would coincide with any rezoning, before permitting

Precedent: APS construction projects

- ACZO amended in 2016 to permit County Board use permit approval of flexibility for schools
- Zoning standards which can be modified:
 - Maximum height
 - Minimum setbacks
 - Maximum density
 - Minimum parking



Alice West Fleet Elementary – Completed in 2019

Use Permits

- County Board approval, typically on consent agenda
 - Land use which may have adverse impacts in certain locations
 - Uses (child care centers, live entertainment, bikeshare stations)
 - Modifications (# of seats in an outdoor café)

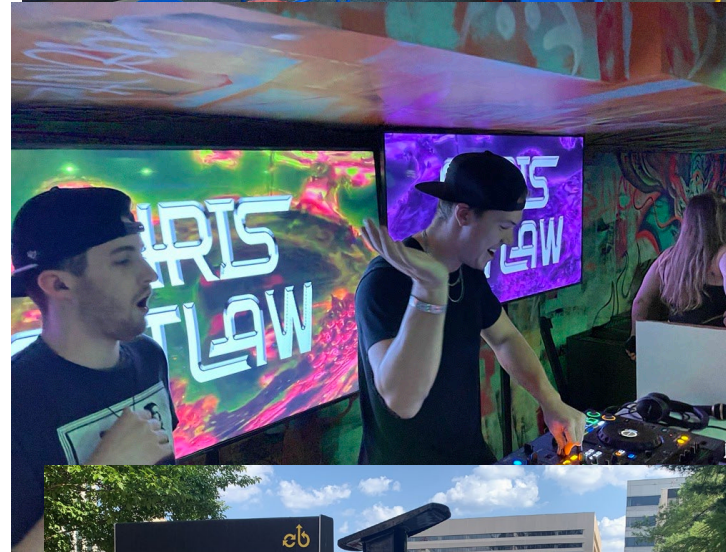

Figure 5 West Aerial View (VMDO Architects)



Figure 6 South Aerial View (VMDO Architects)



Figure 7 Northeast Aerial View (VMDO Architects)

- Schools use permits
 - Modifications permitted for parking, setbacks, lot area, lot width, maximum height

Policy considerations

Flexibility for creative & efficient use of limited public land

Background:

- Arlington's first Zoning Ordinance adopted in 1930
- 46% of County owned parks are less than 2 acres
- More will need to be asked of from smaller spaces
 - natural vegetation, casual use spaces, recreation opportunities
 - stormwater management, environmental sensitivity, utilities
 - demand will continue for land use compatibility

Other factors for zoning evaluation:

- historical park development
- environmental constraints
- equity
- population growth
- emerging trends in park design

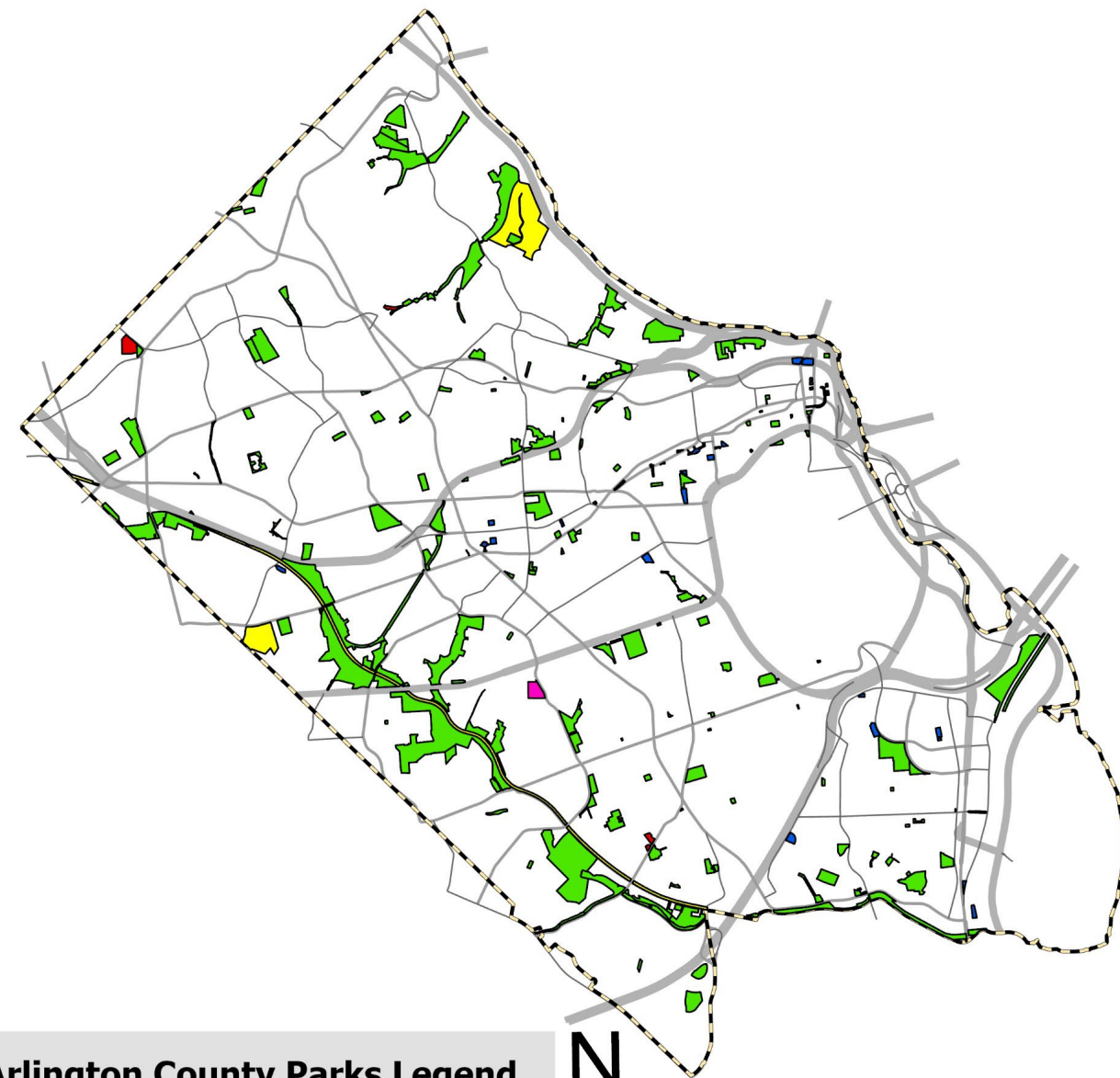

Arlington County Parks Legend

- | | |
|--|--|
| Ownership: Arlington County DES | Ownership: Privately Owned Public Spaces |
| Ownership: Arlington County Parks | Ownership: State Department |
| Ownership: Northern Virginia Regional Park Authority | |



Phase 2 Approach

Examine how County Board could use the use permit approval process to allow the following in public spaces:

- Increased Height
- Reduced Setbacks
- Parking Modifications

Increased Height

Maximum height req. applies to:

- **Buildings** (ex. community center, nature center)
- **Accessory buildings** (ex. storage sheds)
- **Field lighting** where lights already exist
- **Play equipment**
- **Sports field features** (ex. Court or field fencing/netting, dugout/backstop)
- **Temporary enclosures** to enable year-round use (ex. bubble/dome on courts/fields)
- Any park improvements **affixed to the ground**



Public (P) Districts Zoning	Maximum Height (feet)	Maximum Height (feet) + Flagpole (23 feet)
S-3A	45'	68'
P-S	75'	98'

Athletic Field Lighting

Lighting technology has significantly improved by utilizing higher poles to get proper aiming angles to angle the lighting more accurately, helping to avoid overspill and glare.

This amendment will only be applicable to existing lighted athletic facilities.

Any future projects including athletic field lighting will go through the appropriate engagement process.



Case Study: Jennie Dean Park

Example: Jennie Dean Park was rezoned from the M-1/S-3A districts to the P-S district to facilitate the installation of athletic field lighting

S-3A: Max Height – 68'

P-S: Max Height – 98'

SITE PLAN



LEGEND

- A YOUTH DIAMOND FIELD
- B ADULT DIAMOND FIELD
- C MULTI-PURPOSE FIELD
- D DUG OUT TYPICAL
- E BLEACHERS TYPICAL
- F BULLPEN
- G PLAZA
- H BASKETBALL COURT
- I TENNIS COURT
- J LARGE PAVILION
- K PUBLIC ART/ SMALL PAVILION
- L RESTROOMS
- M PLAYGROUND
- N OVERLOOK
- O PARKING
- P DROP-OFF PARKING
- Q BIORETENTION TYPICAL
- R SOFT TRAIL
- S WAYFINDING
- T PICNIC TABLES
- U CUSTOM SEATING
- V EXISTING WALL TO REMAIN
- W FUTURE PEDESTRIAN BRIDGE ?
- X INFORMATIONAL KIOSK/ HISTORIC SIGNAGE

○ PREVIOUSLY DISPLAYED ○ UPDATED INFORMATION



Reduced Setbacks

Constraints which influence park master planning:

- Limited availability of land
- Providing/preserving natural resource access in public spaces
- Existing property boundaries
- Adjacent roads
- Environmentally sensitive areas (ex. RPA)

Must adhere to setbacks

- Buildings (ex. community centers, nature centers)
- Temporary bubble/dome enclosures
- Lighting along walking trails that exceeds 15' in height
- Athletic field/court lighting (existing)
- Fencing which exceeds the maximum height of 8 feet

Setbacks from any street in S-3A: The larger of either **50 feet from said centerline of any street, or **25 feet** from any street right-of-way line.

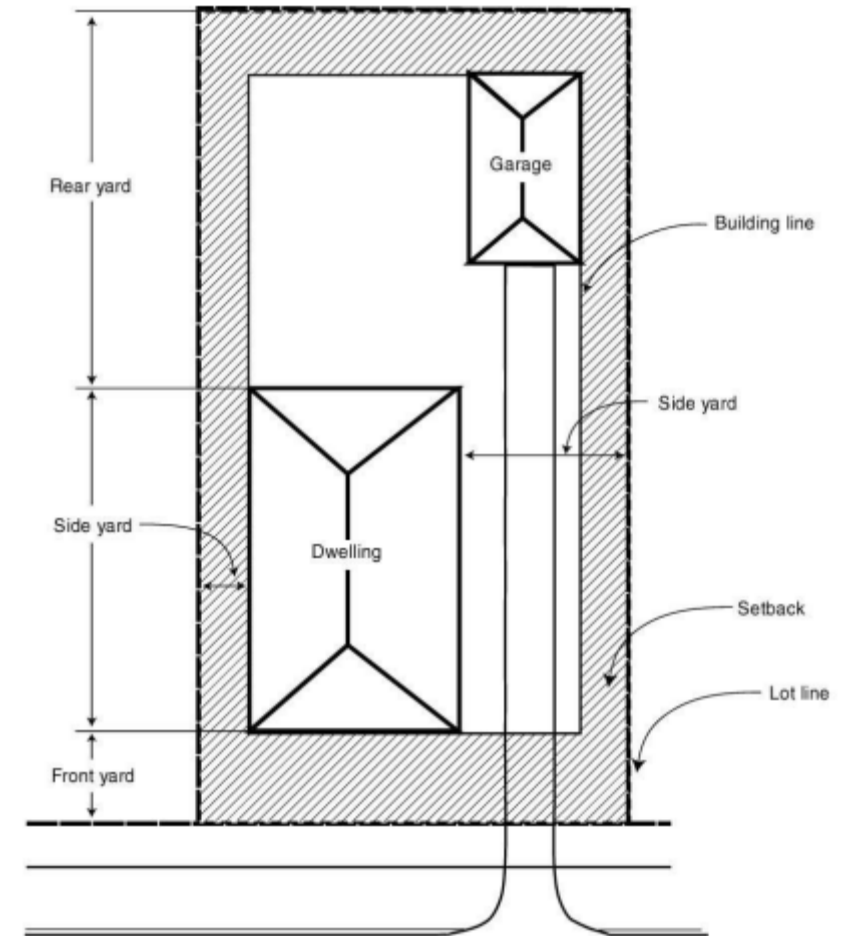

Case Study: Bailey's Branch Park

Location: 990 S Columbus St

Constraints: Narrow/linear, Resource Protection Area, topographical challenges, heavily forested. Current S-3A setbacks would hinder future improvements.



View from S. Columbus St.

Programming: Casual Use & Playground

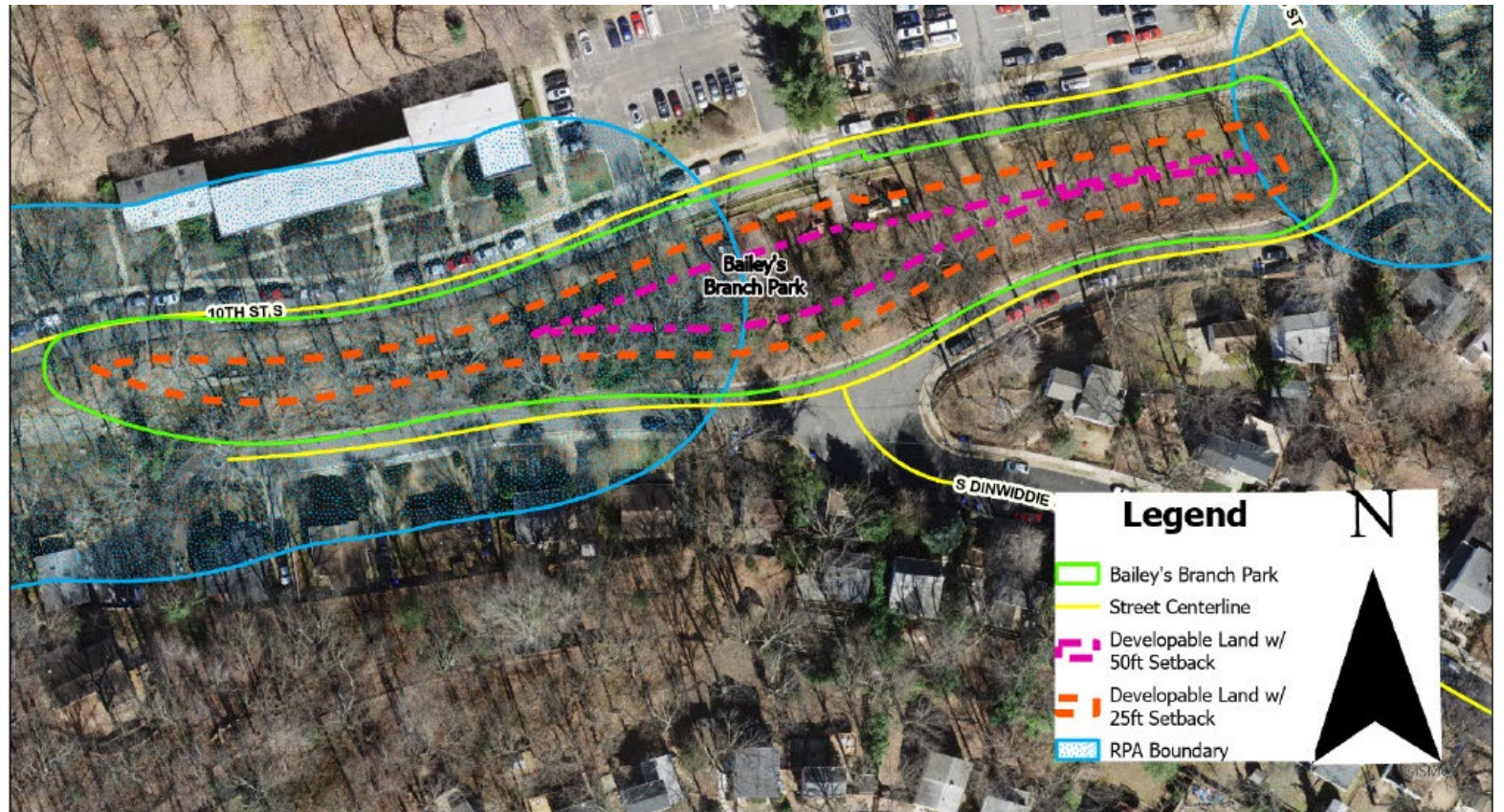

Reduced Setbacks

Example: Upper Bluemont Park – Proposed courts are closer to the street

- * New Entrance with Signage
- ① Existing Sign to Remain
- ② Bioretention Area
- ③ Bicycle Rack/Repair Station
- ④ ADA Access
- ⑤ Casual Open Space
- ⑥ Practice Wall
- ⑦ Emergency Egress
- ⑧ Existing Ballfield (No Changes)
- ⑨ Viewing Terrace
- ⑩ Seating Area
- ⑪ New Auxiliary Building
- ⑫ New Native Plant Material to Stabilize Slopes
- ⑬ Specimen Tree in Excellent Condition
- ⑭ Shade Structure
- ⑮ Maintenance Vehicle Access
- ⑯ RPA Reforestation Area
- ⑰ In-ground Tennis Ball Play Element
- ⑱ Change - Entrance Shifted; Parallel Parking Removed
- ⑲ Change - Hardscape and Play Element Adjusted
- ⑳ Change - Pedestrian Access Shifted; Maintenance Access Added
- ㉑ Change - Pedestrian Access Shifted
- 120'x50' Practice Court (1-2, 6-9)
- 120'x60' Event Court (3-5)
- ⊗ 11 Trees to Be Removed
- ⋯ Edge of Existing Parking Lot and Tennis Court
- Permeable Paving
- RPA Line
- ⋯ Changes since 2nd community engagement

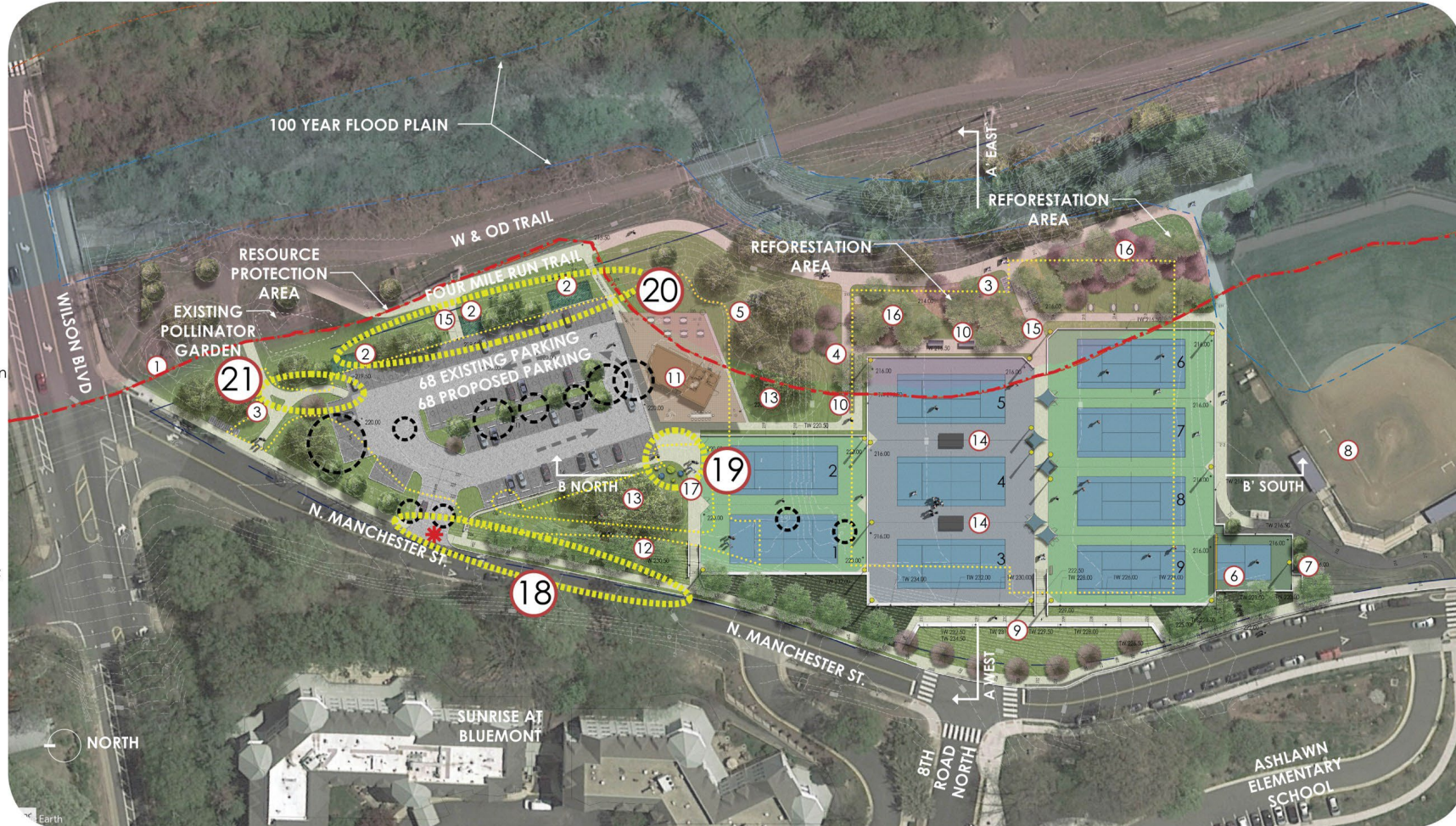

Draft Concept

Zonina Ordinance Setback Exhibit

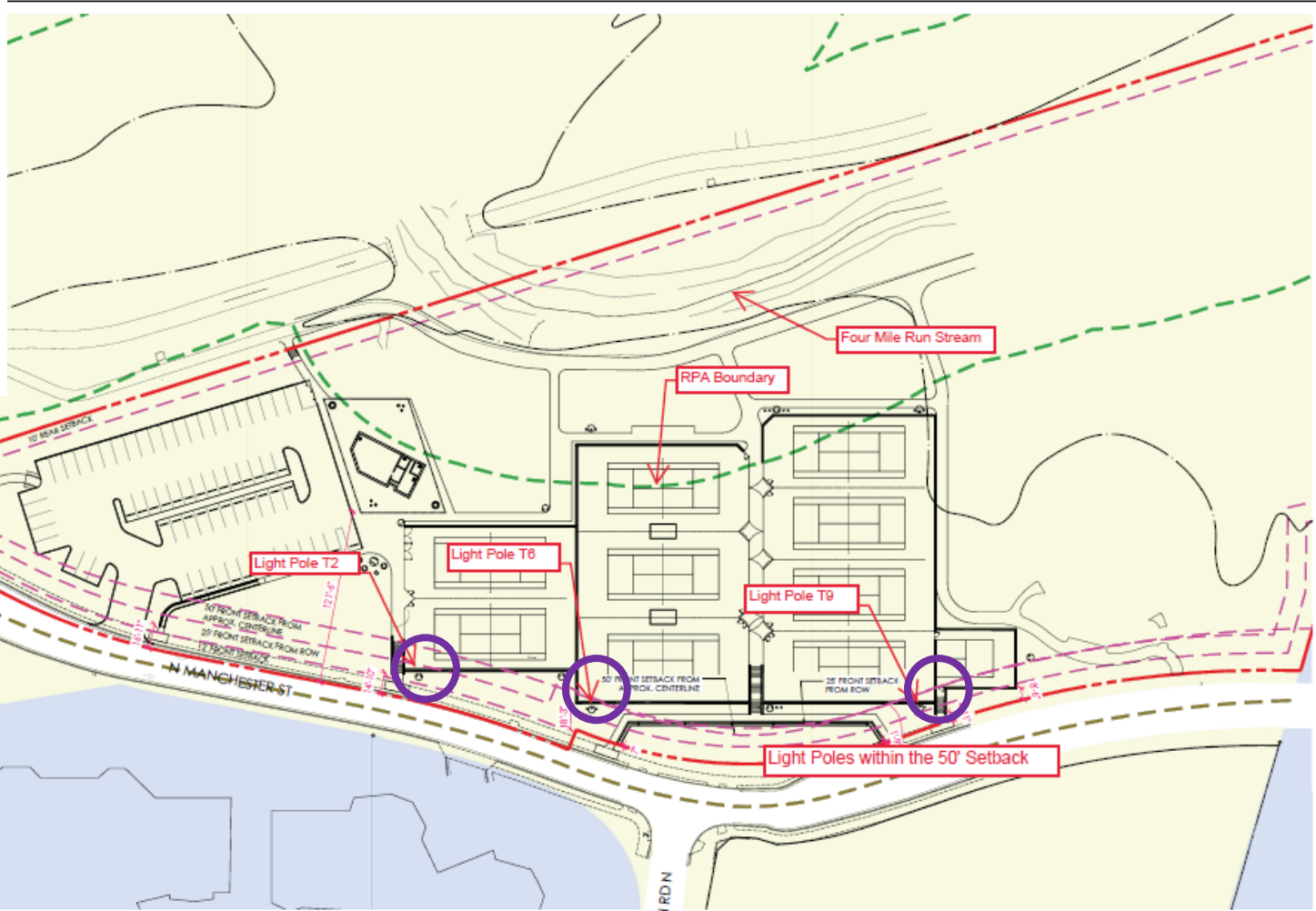

Example: Upper Bluemont Park – Proposed courts are closer to the street
Purple Circles show the athletic court lights that would have to be relocated inside the setbacks.

LEGEND

- Property Line/Right-of-way
- - - RPA
- - - Approximate Centerline
- - - Setback Line
- Tennis Court Lighting
- Zoning: S-3A
- Zoning: R-6

Reduced Setbacks

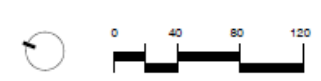

Flexibility for Parking



14.3.7 Required parking and standing space	
Use Types	Minimum Parking Requirement (spaces)
Community swimming pools	1 per each 40 sq. ft. of pool area
Athletic or health clubs	1 space per 50 sq. ft. of gross floor area
Indoor or outdoor recreation	1 space per 300 sq. ft. of indoor floor area or outdoor area
Tennis, racquet and handball courts	3 spaces per court
Community centers	1 space per 3 seats



Flexibility for Certain Signs in Public Spaces

- Flag signs
 - Flag pole must be located within 30' of the principal entrance to the main building
- Freestanding signs
 - Limited to 1 freestanding sign per “entrance”
 - Minimum setback required of either 5' from property lines or 10' feet from back of sidewalk
- **Preliminary approach:** removal/exclusion of limiting zoning language in lieu of use permit modification



Public Engagement to Date

- Website with Reference Materials
- 9/19: Presentation to Park and Recreation Commission (PRC)
- 10/3: Virtual Q&A with Staff for members of the public
- 9/19 - 10/8: Online feedback form to collect public input
 - 242 participants, 275 comments
- October 10: Zoning Committee (ZOCO) briefing

Background > Standards for Consideration > Examples > Feedback > Tell Us About Yourself!

Please use the scale below to share how comfortable or uncomfortable you would be if the County Board had the authority, on a case-by-case basis, to modify the **maximum height** for the following buildings and structures.

	Very Comfortable	Somewhat Comfortable	Neutral	Somewhat Uncomfortable	Very Uncomfortable	Unsure
Community centers, nature centers, aquatics facilities, or other buildings operated by the Department of Parks and Recreation	<input type="radio"/>	<input type="radio"/>	<input type="radio"/>	<input type="radio"/>	<input type="radio"/>	<input type="radio"/>
Lighting structures for athletic fields with existing lights	<input type="radio"/>	<input type="radio"/>	<input type="radio"/>	<input type="radio"/>	<input type="radio"/>	<input type="radio"/>
Other types of structures in a park that are secured to the ground (e.g., flagpoles, signage, etc.)	<input type="radio"/>	<input type="radio"/>	<input type="radio"/>	<input type="radio"/>	<input type="radio"/>	<input type="radio"/>

Should Arlington Allow More Flexibility in the Design Process for Public Spaces?

Share your thoughts now through Oct. 8!

To learn more and sign up for updates, visit Arlingtonva.us and search "Use Permits for Public Space Design Processes"



Online Feedback Form Summary

- 242 participants
- 275 total comments
- Background information provided:
 - Study's goals and objectives
 - Overview of current zoning regulations
 - Rationale for considering flexibility
 - Examples of applicable projects
- Majority of participants were somewhat or very uncomfortable with County Board authority to modify zoning for public spaces

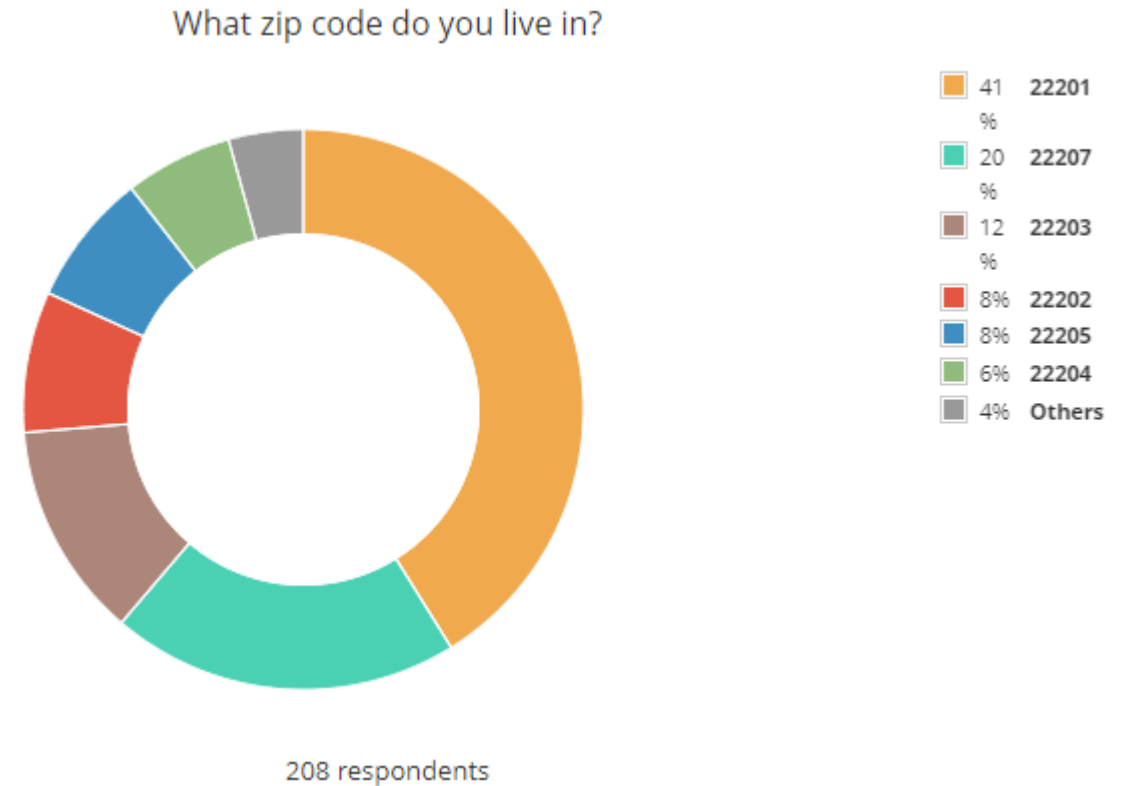

Online Feedback Form Summary

Please use the scale below to share how comfortable or uncomfortable you would be if the County Board had the authority, on a case-by-case basis, to modify the **maximum height** for the following buildings and structures.

	Very Comfortable	Somewhat Comfortable	Neutral	Somewhat Uncomfortable	Very Uncomfortable	Unsure
Community centers, nature centers, aquatics facilities, or other buildings operated by the Department of Parks and Recreation	17% Very Comfortable	10% Somewhat Comfortable	3% Neutral	10% Somewhat Uncomfortable	59% Very Uncomfortable	2% Unsure
Lighting structures for athletic fields with existing lights	17% Very Comfortable	11% Somewhat Comfortable	9% Neutral	13% Somewhat Uncomfortable	49% Very Uncomfortable	2% Unsure
Other types of structures in a park that are secured to the ground (e.g., flagpoles, signage, etc.)	17% Very Comfortable	8% Somewhat Comfortable	14% Neutral	14% Somewhat Uncomfortable	46% Very Uncomfortable	1% Unsure

241 respondents

Please use the scale below to share how comfortable or uncomfortable you would be if the County Board had the authority, on a case-by-case basis, to modify the **minimum requirements for parking** in the following ways.

	Very Comfortable	Somewhat Comfortable	Neutral	Somewhat Uncomfortable	Very Uncomfortable	Unsure
Reductions to the total required parking	15% Very Comfortable	6% Somewhat Comfortable	3% Neutral	8% Somewhat Uncomfortable	66% Very Uncomfortable	1% Unsure
Adjustments to the surface materials, dimensional standards, or other requirements for parking spaces	17% Very Comfortable	8% Somewhat Comfortable	6% Neutral	15% Somewhat Uncomfortable	53% Very Uncomfortable	2% Unsure

239 respondents

Key Themes from Online Feedback Form Comments

- Planning processes need awareness/transparency; outreach to and coordination with community is essential
- Intrusive glare from lighting into neighborhoods should not be allowed
- Overdevelopment of parks; reductions in open space
 - Standards should be added to prohibit net losses in green space
- Parking is in short supply, and essential (ex. sports teams, persons with mobility needs)
- Setback/height standards are essential for maintaining open space and separation from adjacent homes



Anticipated Schedule

November 2: Public Spaces Master Plan-IAC

November 11/14: County Board to authorize Request to Advertise (RTA)

December 4/6: Planning Commission public hearing and recommendation

December 16/19: County Board public hearing and action



Arlington Junction Park