

**Site Plan Review Committee (SPRC)**  
**Staff Report for**  
**1840 Wilson Blvd. – NSTA Site**

There are multiple ways to provide feedback and input on the proposal, County Staff is happy to accept comments in any form. Please use any method listed below.

**Mail-in Comments:**

Arlington County Planning Division  
c/o Courtney Badger  
2100 Clarendon Blvd. Suite 700  
Arlington, VA 22201

**Contact Staff:**

*Contact the Arlington County Planning Staff reviewing this project either by phone or email*

**Courtney Badger**

703-228-0770

[cbadger@arlingtonva.us](mailto:cbadger@arlingtonva.us)

**Contact the SPRC Chair**

*The SPRC Chair is a member of the Planning Commission and conducts all SPRC meetings*

**Sarah Steinberger, Chair**

[aripcsteinberger@gmail.com](mailto:aripcsteinberger@gmail.com)

**Karen Guevara, Co-Chair**

[karenguevarapc@gmail.com](mailto:karenguevarapc@gmail.com)

**NSTA Site (SP #382)**  
**1840 Wilson Blvd. (1805 Clarendon Blvd.)**  
(RPC#s 17-011-057, -056)

Public Review and Site Plan Review Committee (SPRC) Process:

- Online Engagement Session: January 3 – January 11, 2024
  - Topics:
    - Land Use & Density
    - Site Design
    - Building Form & Architecture
    - Transportation
    - Landscaping
- Hybrid SPRC Meeting #1 – February 22, 2024
  1. Introductions
  2. Staff & Applicant Presentations
  3. SPRC Discussion Topics:
    - a. Site Design
    - b. Building Height and Massing
    - c. Architecture
    - d. Landscaping & Biophilia
  4. Public Comment
  5. Wrap-up
- Hybrid SPRC Meeting #2 – April 15, 2024
  1. Introductions
  2. Staff & Applicant Presentations
  3. SPRC Discussion Topics
    - a. Transportation
    - b. Community Benefits
    - c. Construction Phasing
  4. Public Comment
  5. Wrap-up

**Glossary of Terms:**

Area Median Income (AMI): The income at which half of the families of a particular household size have incomes higher and half have incomes lower.

By-Right Development: May be approved administratively in the respective zoning district subject to all other applicable requirements of this zoning ordinance. Is not required to seek approval by the County Board.

Density: The ratio of a particular use given the area of land. Density measures the intensity of a given land use.

Floor Area Ratio (FAR): The gross floor area of all buildings on a lot divided by the lot area.

General Land Use Plan (GLUP): The GLUP is the primary policy guide for future development in the County. The GLUP establishes the overall character, extent and location of various land uses.

Gross Floor Area (GFA): Gross floor area is the sum of the area of the horizontal surface of the several floors of a building measured from the exterior faces of exterior walls, to include all floor area not defined as gross parking area.

Phased Development Site Plan (PDSP): A type of Site Plan; to permit the coordinated development of sites of more than twenty (20) acres in area, or a smaller area as authorized and accepted by the County Manager, the County Board may approve a Phased Development Site Plan (PDSP) in the form of a general plan for land uses, public facilities, transportation, and utilities.

Zoning Ordinance (ACZO): County adopted ordinance that regulates the use and development standards of all land located within the County. There are various zoning districts within the zoning ordinance and each district sets the standards for development. Examples of such requirements are: maximum heights, required parking, required setbacks, density, etc.

**SITE PLAN REVIEW COMMITTEE  
MEETING AGENDA**

**DATE:** February 22, 2024  
**TIME:** 7:00 PM  
**PLACE:** 2100 Clarendon Blvd. Room 216

**SPRC STAFF COORDINATOR:** Matthew Pfeiffer

- Item 1. NSTA Site (SP #382)**  
**1840 Wilson Blvd. (1805 Clarendon Blvd.)**  
**(RPC#s 17-011-057, -056)**  
Planning Commission and County Board meetings to be determined.  
*Courtney Badger (CPHD Staff)*

The Site Plan Review Committee (SPRC) is comprised of Planning Commission members, representatives from other relevant commissions and several appointed citizens. The SPRC reviews all site plans and major site plan amendments requests, which are submitted to the County Board and the Planning Commission for consideration. The major responsibilities of the SPRC are the following:

1. Review site plan or major site plan amendment requests in detail.
2. Advise the Planning Commission by recommending the appropriate action in regard to a specific plan and any conditions, which it might determine to be necessary or appropriate.
3. Provide a forum by which interested citizens, civic associations and neighborhood conservation committees can review and comment on a particular plan, or the effects that the proposed project might have on the neighborhood.

In order to save copying costs, staff has selectively chosen the reduced drawings to be included in this package. The complete full size drawings are available for review in the Arlington County Zoning Office, 10th Floor, Courthouse Plaza, 2100 Clarendon Boulevard and also in the Central Library's Virginia Room, 1015 N. Quincy St., (703) 228-5990.

For more information on the Arlington County Planning Commission, go to their web site  
<http://commissions.arlingtonva.us/planning-commission/>

For more information on the Site Plan public review process, go to the Arlington County Planning Division's web site on Development Proposals/Site Plans  
[http://www.arlingtonva.us/Departments/CPHD/Planning/applications/site\\_plans/CPHDPlanningApplicationsSite\\_plansMain.aspx](http://www.arlingtonva.us/Departments/CPHD/Planning/applications/site_plans/CPHDPlanningApplicationsSite_plansMain.aspx)

To view the current Site Plan Review Committee schedule, go to the web site  
<http://commissions.arlingtonva.us/planning-commission/sprc/>

**SUMMARY:** The applicant, Fortis, proposes a Site Plan Amendment (#382) to develop the site (“NSTA Site”) with a 7-story mixed-use building, consisting of ground floor retail and residential dwelling units above.

Additional project details include:

- 188 dwelling units
- Approximately 12,000 sq. ft. ground floor retail space
- Residential parking ratio – 0.53 spaces/unit
- Retail parking ratio – 1 space per 664 sqft retail space
- Requested modifications for: Additional density, density exclusions, and reduced parking ratio

**BACKGROUND:** In 2003, at the time the County Board adopted The Rosslyn to Courthouse Urban Design Study (RCUDS), the subject site, which is comprised of two (2) parcels, was developed with a NSTA Office Building, Rhodeside Grill and Il Radicchio restaurant.

In 2005, the County Board approved a [site plan \(SP #382\)](#) covering both parcels for the development of a 6-story office building with 61,840 square feet of office space and 10,000 square feet of ground-floor retail. The approved site plan remains unbuilt, however, is still valid until 2024. The proposed site plan amendment to construct a mixed-use residential building, if approved, would supersede the previous approval.

**The following provides additional information about the site and location:**

Site: Site is currently developed with an office building occupied by the National Science Teaching Association and two restaurant buildings, Rhodeside Grill and Il Radicchio.

Address / RPC#                      1840 Wilson Blvd;  
RPC#s: 17-011-056, -057

Neighborhood                      Radnor Fort Myer Heights Civic Association; adjacent to  
Colonial Village Civic Association

Zoning:                                      “C-O-2.5,” Mixed Use District

GLUP Designation:                      “Medium” Office-Apartment-Hotel

**Aerial View of Site:**



**Existing Development:** The site is currently developed with the National Science Teacher Association office building (NSTA building), Rhodeside Grill, and Il Radicchio restaurant. A surface parking lot, located between the restaurant pads and the NSTA building, is accessed by curb cuts on Wilson Blvd. and Clarendon Blvd. The Rhodeside Grill and Il Radicchio buildings are listed on the [County's Historic Resources Inventory](#) under the notable and minor categories respectively.

**(L) View from Wilson Blvd of NSTA Office Building; (R) View from Wilson Blvd of Rhodeside Grill**

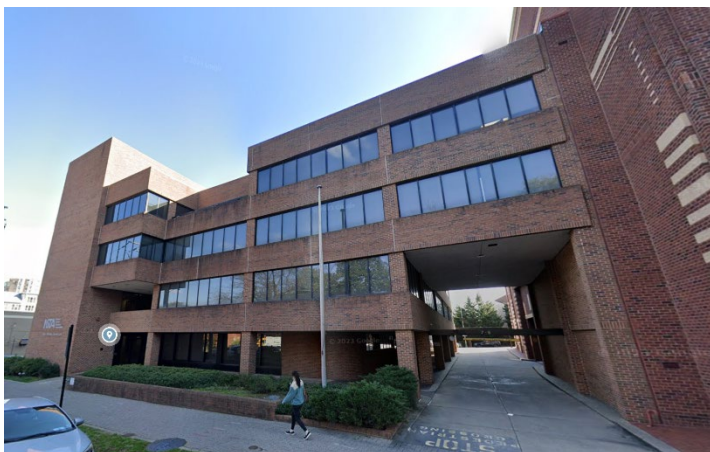

**View from Clarendon Blvd of Il Radicchio restaurant**



**Development Potential:** The following provides a statistical summary of the development potential for the site area.

Site Plan Area (SP #382): 43, 901 sqft (1.01 acre)	Density Allowed for Proposed Uses	Maximum Development
By-Right: "C-O-2.5" District		
	One-family dwelling unit	7 dwelling units
	All other uses (0.6 FAR)	26,340 sq. ft. GFA
Special Exception Site Plan: "C-O-2.5" District		
	Institutional Uses (2.5 FAR)	109,752 sq. ft. GFA
	Office, Commercial (2.5 FAR)	109,752 sq. ft. GFA
	Multiple-family (115 du/ac)	116 dwelling units
	Hotel (180 units/ac)	181 units
	All other uses (0.6 FAR)	26,340 sq. ft. GFA



**WILSON LOOKING WEST**

**Proposed Development<sup>1</sup>:** The following provides a statistical summary of the proposed development for SP #382:

**Site Plan #382 (“C-O-2.5” District)**

<b>SPLN23-00010 – NSTA Site Plan</b>		
	<b>Approved (2005 Site Plan)</b>	<b>Proposed</b>
<b>Site Area (sq. ft.)</b>		
Total Site Area	50,880 sqft 1.168 acres	43,901 sqft 1.01 acres
<b>Density/Uses</b>		
Office (sq. ft. GFA)	107,920 sqft	----
Residential Units	----	188 units 168,676 sqft
Commercial/Retail (sq. ft. GFA)	10,000 sqft	11,948 sqft
Density Exclusions (sq. ft. GFA)	----	8,171 sqft
<b>Total Density</b>	117,920 sqft	186,240 sqft
Base Density	127,200 sqft	104,119.65 sqft
Bonus Density <i>Green Building Incentive Program</i> <i>Community Benefits</i>		0.35 FAR - 15,365.35 sqft 61,139 sqft
<b>Building Height</b>		
Main Roof Height (from average site elevation)	60’ – 9.6”	85’
Mechanical Penthouse Height	69’ 3.6”	93’ - 1 ¼”
Number of Stories	6-story	7-story

	<b>ACZO Requirement</b>	<b>Proposed</b>
<b>Parking/Loading</b>		
<b>Parking</b>		
Residential spaces	256	102
Residential ratio	1.125/du + 1/du (over 200)	0.53 per unit
Residential visitor spaces	10	13
Retail spaces	16	16
Retail ratio	1 per 250 sq. ft.	1 space per 664 sqft
Compact parking	15%	32%
<b>TOTAL spaces</b>	272	118
<b>Loading Spaces</b>		
Residential	2	1
Retail	1	1



**Density and Uses:** As described in the table above, the applicant is proposing a new 7-story multifamily residential building with ground floor retail, totaling 180,624 sqft, with 188 dwelling units and 11,948 sqft of retail. The applicant will be required to earn a portion of that density and is proposing to earn 0.35 FAR through participation in the Green Building Incentive Program. The additional provision of community benefits to earn additional density will be discussed throughout the process and negotiated with County staff.

In addition, there are several zoning modifications requested.

Requested Zoning Modifications (SP #382):

- Bonus density for LEED Gold certification
- Bonus density to be achieved in conformance with ACZO §15.5.9
- Reduced residential and retail parking requirements
- Density exclusions for mechanical space

**Site Layout and Building Design:** The proposed residential building with ground floor retail is situated on the eastern portion of the block fronting on Wilson Blvd, Clarendon Blvd, and Rhodes Street. The existing alley between the current NSTA building and residential building to the west will remain and will provide access to the underground parking garage (existing to remain) and loading functions. Additionally, a pedestrian walkway is proposed to be included in the alley that bisects the block.

**Proposed Site Layout**

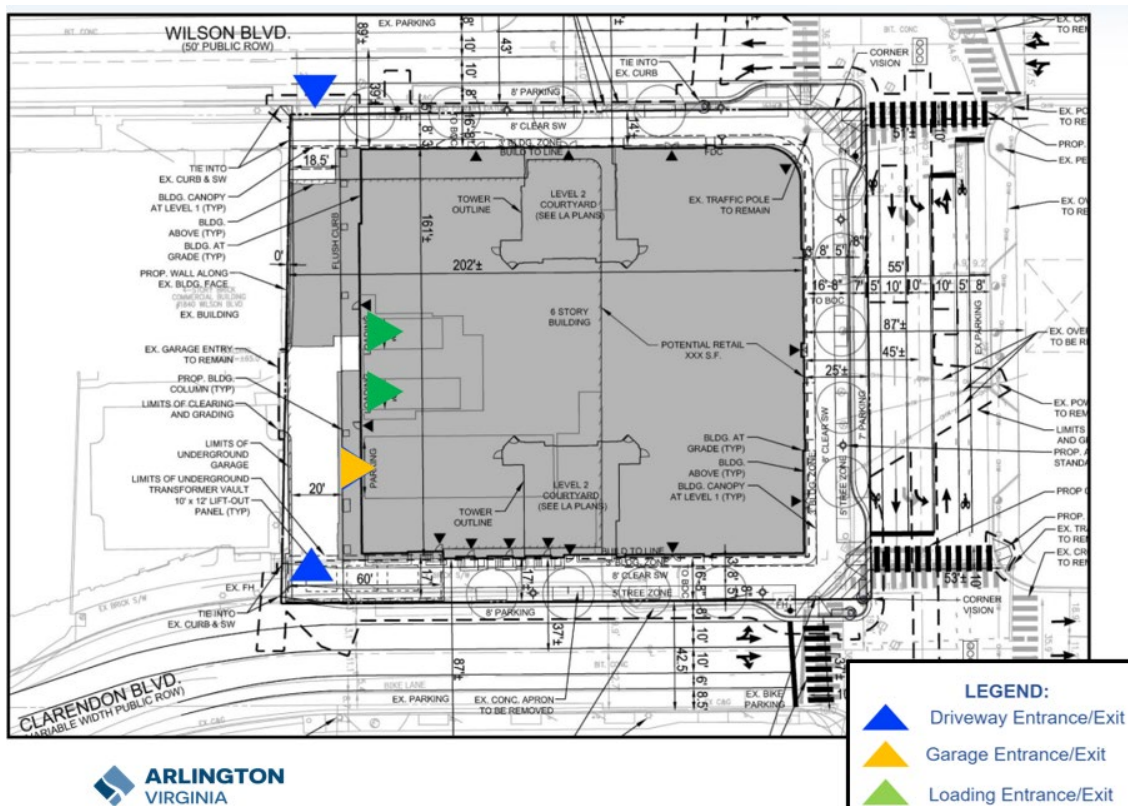

Ground floor retail entrances will be positioned along Rhodes Street and on the eastern edges of Wilson and Clarendon Boulevards. Residential entrances will line the western edge of the Clarendon Boulevard frontage and residential lobby entrance will line the western edge of the Wilson Boulevard frontage. Building massing is broken up with courtyards along the north and south facades of the building, with other vertical blocks that break up the façade.



**CLARENDON - MID BLOCK**



**WILSON - MID BLOCK**



In the site vicinity, Wilson Boulevard fits this typology as it serves a densely populated and highly traveled area with both transit and enhanced bicycle facilities provided within the street right-of-way. The existing lane configurations and bike facility widths for Wilson Boulevard will be maintained at approximately 43 feet curb-to-curb. Existing Wilson Boulevard’s streetscape along the site frontage consists of a 10’ clear sidewalk and 4’ tree pits with two driveways serving existing surface parking lot and alley. The street sections proposed by this project show to increase the total streetscape width to 16’8”, including 5’ tree pits with 8” step-off area, 8’ clear sidewalk, and 3’ shy zone. The applicant is proposing to remove one existing driveway serving the surface parking lot and will maintain the alley driveway. The R-B Corridor streetscape plans call for a 16’8” total streetscape including 5’x8’ (or larger) tree pits, which the applicant is meeting. The proposed sections are as shown below.

**Wilson Blvd Street Section looking West (Left); Wilson Blvd Sidewalk Section (Right)**

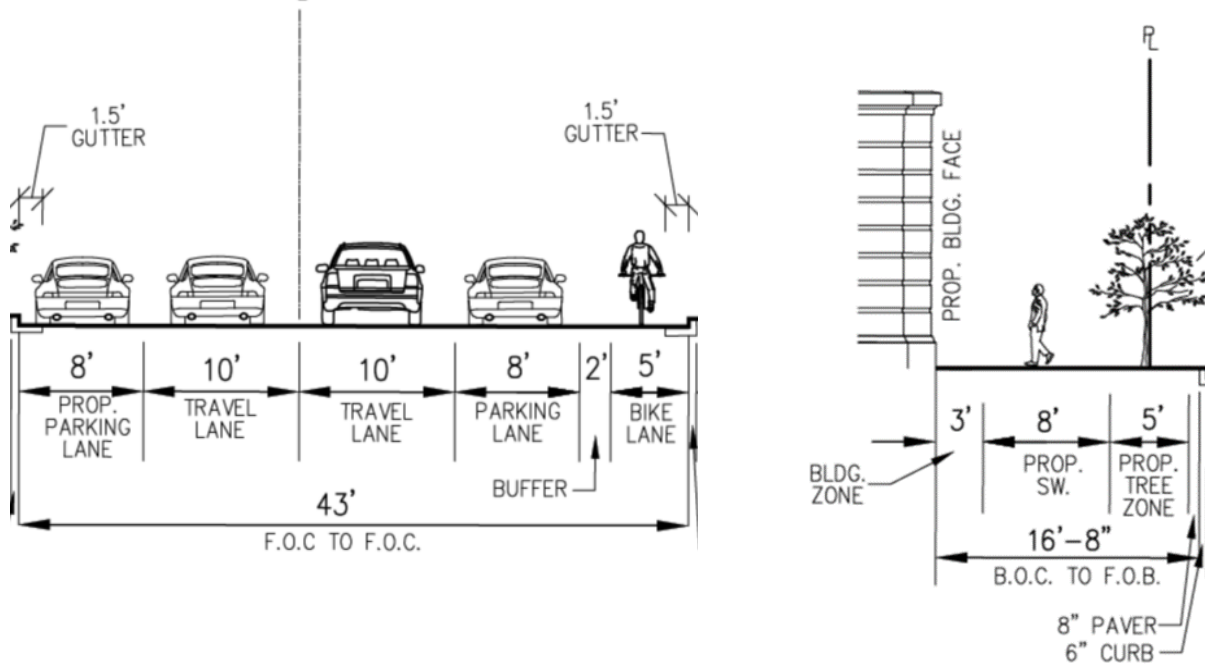

*Rhodes Street*: North Rhodes Street is classified on Arlington County’s master transportation Plan (MTP) map as a Type D arterial (Primarily Garden Apartments & Townhouse Neighborhoods), with a posted speed limit of 25 miles per hour (mph) in the vicinity of the site. Such a street typology, according to Arlington County’s MTP Streets Element (2011) includes the following:

“An arterial street segment that serves (or is planned to serve) a primarily residential area with medium to high densities, such as multistory residential buildings. This street emphasizes pedestrian, transit, bicycle travel, and motor vehicle access.”

In the site vicinity, North Rhodes Street meets parts of this typology. While it is in a medium to high densely populated and travel area and has transit facilities nearby, it has limited bicycle facilities adjacent to the site. The existing lane configurations will be maintained though the

curb-to-curb width will be reduced from 55.7 feet to 55 feet. Within the curb-to-curb width the applicant is proposing a new southbound bike lane previously treated as a shared-use lane with a southbound motor vehicle lane. It's sidewalk is an 8' width with no tree pits or landscape buffer but there are numerous sign posts. There are no driveways along North Rhodes Street adjacent to site and none are proposed by the applicant. The street sections proposed by this project show to increase the total streetscape width to 16'8", including 5' tree pits with an 8" step-off area, 8' clear sidewalk, and 3' shy zone. The R-B Corridor streetscape plans call for a 16'8" total streetscape including 5'x8' (or larger) tree pits, which the applicant is meeting. The proposed sections are as shown below.

**Rhodes Street Section looking North (Left); Rhodes Street Sidewalk Section (Right)**

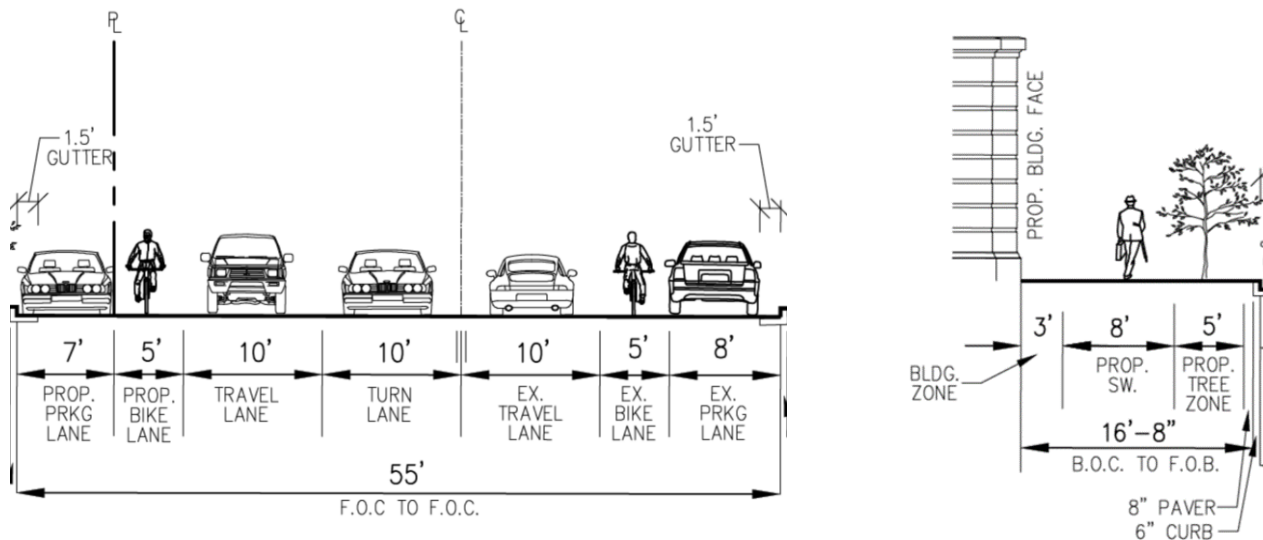

**Clarendon Boulevard:** Clarendon Boulevard is classified on Arlington County's Master Transportation Plan (MTP) map as Type B arterials (Primarily Urban Mixed-Use), with a posted speed limits of 25 miles per hour (mph) in the vicinity of the site.

In the site vicinity, Clarendon Boulevard fits this typology as it serves a densely populated and highly traveled area with both transit and bicycle facilities provided within the street right-of-way. The existing lane configurations will be maintained though the curb-to-curb width will be reduced from 47.2 feet to 42.5 feet. At the intersection with North Rhodes Street the applicant proposes a curb extension. Clarendon Boulevard's sidewalk along the site's frontage vary in width from a suitable width (16') to barely adequate (6'). Along the site's frontage on Clarendon Boulevard there are three existing driveways serving the existing surface parking lot, loading dock, and alley. The street sections proposed by this project show to increase the total streetscape width to 16'8", including 5' tree pits with an 8" step-off area, 8' clear sidewalk, and a 3' shy zone. The applicant is proposing to remove two existing driveways serving the surface parking lot and loading dock and will maintain the alley driveway. The R-B

Corridor streetscape plans call for a 16'8" total streetscape including 5'x8' (or larger) tree pits, which the applicant is meeting. The proposed sections are as shown below.

**Clarendon Blvd Street Section looking East (Left); Clarendon Blvd Sidewalk Section (Right)**

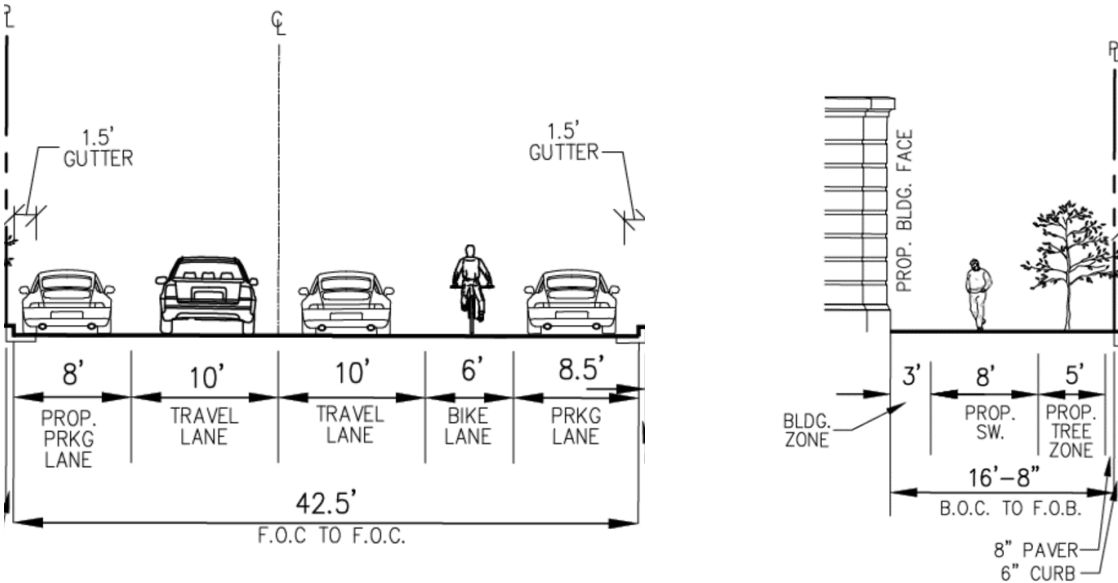

Staff are working with the applicant to coordinate projects to have a cohesive design and to minimize disruption during construction activities.

**Transit Service:** The subject site is served by multiple public transportation options including regional bus service; the Washington Metropolitan Area Transit Authority (WMATA) Metrorail system. The project is served by several bus routes operated by Arlington Transit (ART) and MetroBus, providing for high frequency service. There is an existing bus stop north of the site on Wilson Boulevard serving the ART routes 61A, 45 and MetroBus routes 4B, and 38B is proposed to remain. There is also an existing bus stop just southeast of the site at the southeast corner of the Clarendon Boulevard and N Rhodes intersection. This stop provides service to the ART route 45 and MetroBus routes 4B, and 38B. The closest Metro rail Station, Courthouse, is located approximately ¼-mile to the west of the subject site. The Courthouse station provides access to the Orange and Silver lines. The Rosslyn Metro rail station is also nearby, located approximately ½-mile to the east of the subject site. The Rosslyn station provides access to the Orange, Silver, and Blue lines.

**Bicycle Facilities:**

The site is located along dedicated bicycle routes on both Wilson Boulevard and Clarendon Boulevard as identified in the MTP Bicycle Element as Primary Bicycle Corridors. Wilson Boulevard has a protected bike facility treatment in the westbound direction adjacent to the site. Clarendon Boulevard has standard bike lanes in the eastbound direction adjacent to the site. North Rhodes Street is not a Primary Bicycle Corridor but is called out as an on-street route in the MTP Bicycle Element as it provides connections to primary corridors. North Rhodes Street adjacent to the site has a southbound shared lane facility and a northbound

standard bike lane. There are also two (2) Capital Bikeshare stations within 500 feet of the site, along Wilson Boulevard at the intersection with North Troy Street and along North Rhodes Street south of Clarendon Boulevard. As part of this project, the applicant is upgrading the existing shared lane facility on N Rhodes Street to a standard bike lane. The applicant is also providing 81 Class 1 spaces and eight (8) Class III visitor spaces which meets the minimum required.

Multimodal Transportation Analysis and Trip Generation: A Multimodal Transportation Assessment (MMTA) was submitted by the applicant, prepared by Wells and Associates, dated June 30, 2023. The analysis concluded that the proposed development program will generate less than the previously approved program in 2005 which included office and retail uses. When compared to the currently approved development program, the proposed program would generate 34 fewer AM peak hour trips, 34 fewer PM peak hour trips, and 208 fewer daily trips.

Parking and Loading: The applicant is proposing to retain and reuse the existing underground parking garage on the site for a total of 118 parking spaces, including 102 residential spaces (13 visitor spaces) and 16 retail spaces. The parking and loading will be accessed from an existing alley on the western portion of the site from Clarendon and Wilson Boulevard between the proposed building and the existing residential building to the west. The proposed residential parking ratio is 0.53 spaces per unit and retail parking ratio is 1 space per 664 commercial sqft. The alley is proposed to have two loading docks, one for retail and one for residential. All turning movements to access the garage and loading docks will be made within the alley and off the arterial roadways.

**DISCUSSION:** The following provides staff’s analysis of the proposal:

**GLUP:** The General Land Use Plan (GLUP) designation for the site is “Medium” Office-Apartment-Hotel. The applicant is not requesting to change the GLUP designation. This designation allows for typical base density of up to 2.5 FAR for commercial/office, 115 units per acre for residential, and/or 180 rooms per acre for hotel. Moreover, the designation aligns with the existing zoning for the site (C-O-2.5, Mixed Use District), discussed further in the section below. The applicant’s proposal is consistent with the GLUP.

**Zoning:** The subject site is zoned “C-O-2.5” Mixed-Use District, and there is no proposal for a rezoning. As discussed in the GLUP section above, the permitted base density in this district is up 2.5 FAR for commercial/office, 115 units per acre residential, and/or 180 rooms per acre for hotel. The County Board may approve additional density consistent with ACZO 15.5.9. Office buildings are permitted a maximum height of 12 stories, while institutional, residential, and hotel buildings are permitted a maximum of 16 stories. Enclosed mechanical penthouses are not counted as a story, but may also be used for private clubs, auditorium, meeting rooms, and restaurants. The applicant’s proposal is

consistent with the requirements of the “C-O-2.5” district.

**The Rosslyn to Courthouse Urban Design Study (RCUDS) (2003):** The RCUDS is the primary policy document guiding land use and development for the subject site. The subject site is comprised of two (2) parcels, identified in the RCUDS as the “NSTA” site. Adopted in 2003, the RCUDS established a vision for the study area as:

- A Place that Embodies the Arlington County’s Vision;
- A “Meeting Ground” and Activity Node for nearby neighborhoods and offices day and evening, weekdays and weekends, year-around;
- A Service Center for shopping, eating, entertainment and recreation;
- Vibrant and people-friendly streets and plazas are full of life with a strong identity; and
- Small businesses prosper and affordable housing integrated in the diverse community.

In addition, the RCUDS established “Urban Design Guidelines” at three interrelated, spatial levels: Guiding Principles, Area-Wide Guidelines, and Site-Specific Guidelines. The discussion below provides a preliminary analysis of the proposal with respect to several of the most relevant principles from the RCUDS and the existing, approved site plan. Staff analysis of the project will continue throughout the SPRC review period.

Land Use: Per the RCUDS, the preferred land use scenario for the subject site is first-floor retail with office or residential above. The applicant’s proposal is consistent with the RCUDS recommended land use scenario as it includes ground-level retail, and retail equivalent uses with six-floors of residential above. Staff will continue to evaluate this proposal via the Administrative Guidance for Office Conversion, given the request to change the principal land use of the approved site plan from office to residential.

Site Design: The RCUDS identifies several design recommendations for this site including no curb cuts on Rhodes St, pedestrian friendly treatment on the ground floor, parking and loading accessed from the alley, and continued 12-foot minimum sidewalk along Rhodes Street and 16-foot minimum wide sidewalk along Wilson Boulevard and Clarendon Boulevard. Most of these design recommendations are being met in the applicant’s proposal. However, the residential stoops on Clarendon Blvd encroach into the recommended 8-foot clear zone creating a non-continuous clear zone with a pinch point of 6.5-foot clear sidewalk. The encroachments can be seen marked by the narrow red lines in the image below.



### Clarendon Blvd. Encroachments

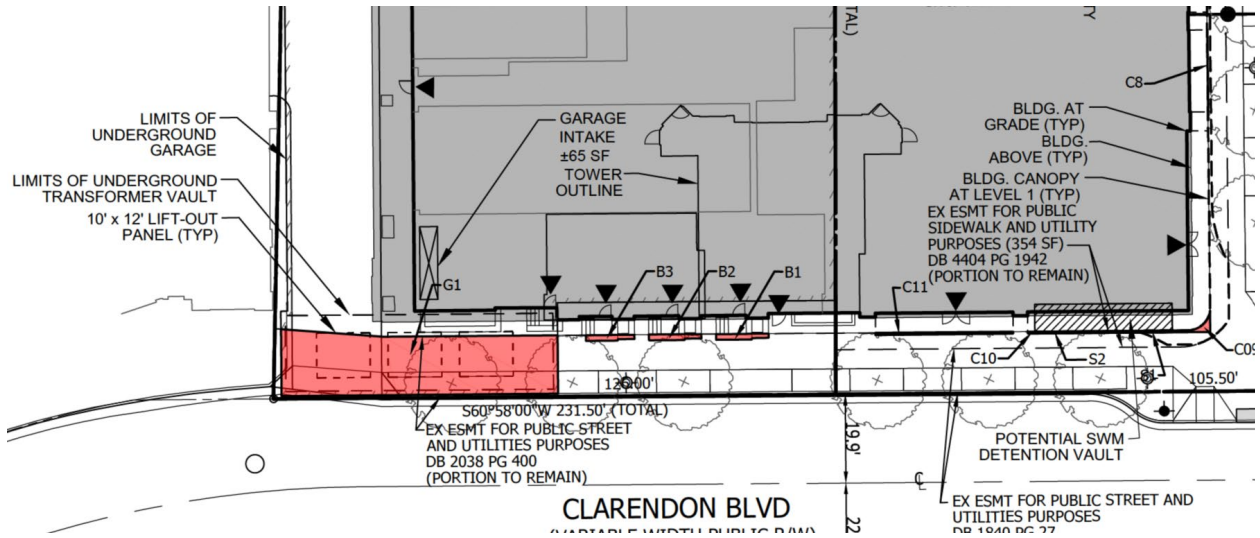

**Building Height and Massing:** The applicant is proposing a 7-story building, with building step backs at the 6-story level along all sides of the building and step backs at the second story along the north and south sides of the building. The RCUDS recommends a 5-story building, 55-feet tall, at this location. The RCUDS recommends flexibility for building heights to “accommodate affordable housing, community facilities, special design considerations, and/or new streets.” Moreover, the existing approved, but unconstructed office approval is permitted up to 6-stories.

### Building Height – Site Section Rhodes Street

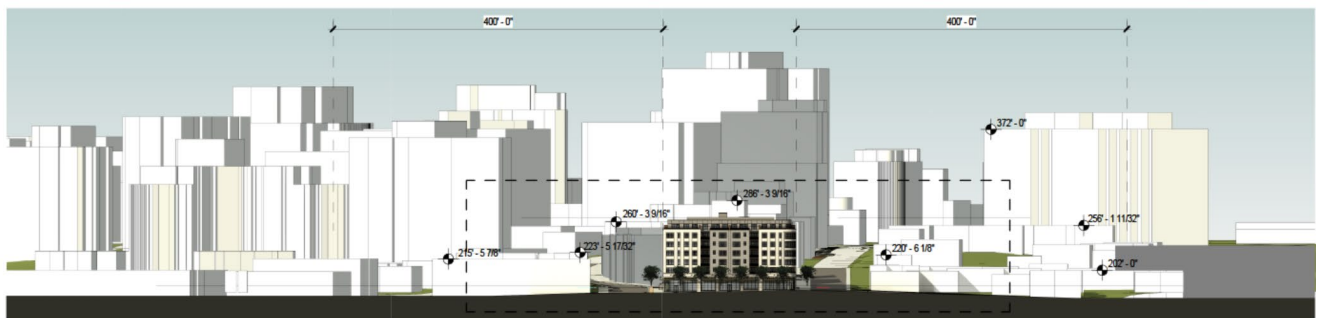

2 ZA SITE SECTION RHODES - 100  
A-01.01 SCALE: 1" = 100'-0"

The RCUDS recommends a horizontal treatment at the second floor to relate to historic buildings across Wilson Boulevard. Additionally, 20-foot building massing step backs are recommended above the second floor along Clarendon and Wilson Boulevards. The applicant’s proposal includes a horizontal treatment at the second floor to differentiate the ground floor and create a pedestrian scale architecture. The facades along Clarendon and Wilson Boulevards include carved out courtyards and vertical carve-outs. Staff is continuing to analyze the building height and massing to ensure it is meeting the intent of





**Historic Resources Inventory:** The Rhodeside Grill and Il Radicchio buildings are listed on the [County’s Historic Resources Inventory](#) (HRI) under the notable and minor categories respectively. Neither of these properties falls into the Essential or Important categories. Notable properties have historic elements related to County’s history, but lack sufficient historic context, integrity, and/or significance compared to Essential and Important properties. Properties that are categorized as minor have altered substantially over time and/or are not distinctive examples of their building type. Neither building is identified in the HRI for building preservation. The proposed curved design of the corner of the building at Wilson Blvd. and Rhodes St. mimics the curved façade of Rhodeside Grill to honor the Rhodeside Grill building. Staff will continue to work with the applicant throughout the process to identify ways to honor the historic nature of the buildings.

**Arlington County Retail Plan (2015)**

The Retail Plan identifies ground-floor frontages appropriate for retail within the subject site area on the Retail Street Map for Courthouse.

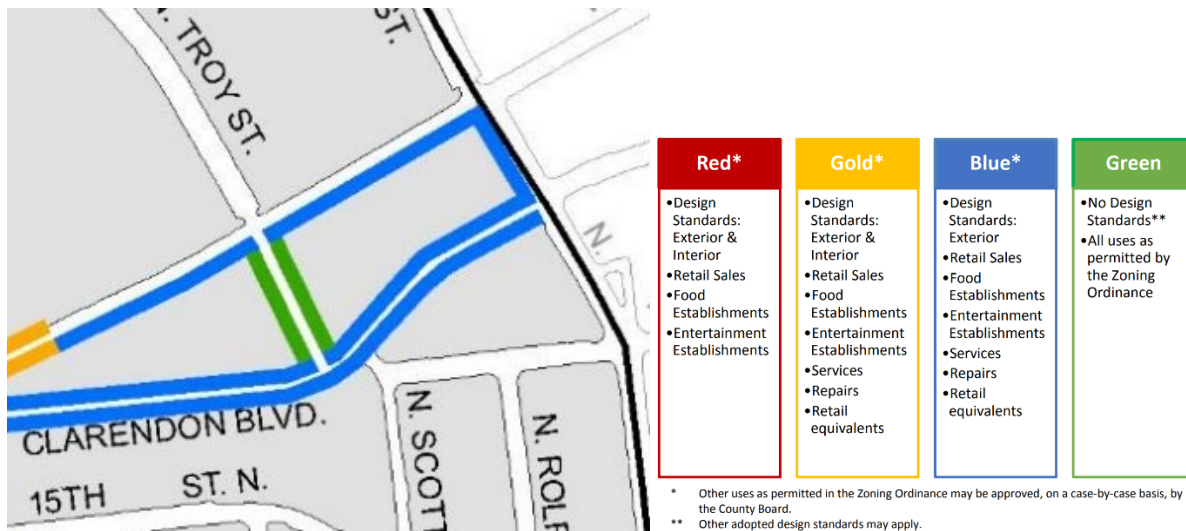

The site includes Blue Street typography along Rhodes Street, Clarendon Boulevard, and Wilson Boulevard. Blue Streets are “planned for any type of retail use or retail equivalent as permitted by the Zoning Ordinance.” Blue Streets call for only exterior design elements to support retail and retail equivalent uses, including window transparency of approximately 50%.

**Administrative Guidance for Office Conversion:** The purpose of these guidelines is to provide consistently applied administrative guidance on Key Areas of Consideration when reviewing office conversion proposals, such as this proposal. Staff developed this Administrative Guidance to provide a clear and consistent framework for staff analysis and presentation, and ultimately the formation of a formal staff recommendation. It is also an important tool for use by advisory commissions, community members and property owners/developers to be able to discuss the merits of a land use proposal through a consistent and transparent framework. Key Areas of Consideration include:

- Existing PDSP approval and/or land use policy guidance
- Transformative nature of infrastructure improvements
- Proposed conversion results in equally or more desirable land use type
- Systemic office demand/clustering/critical mass
- Adjacent areas of significant future supply
- Transportation infrastructure
- Amenities
- Site/building constraints
- Creative workplaces

This section will be updated further as the public review progresses and will be discussed at the first virtual SPRC meeting.